

Gas Springs

ACE Controls gas springs are reliable units designed to handle the demanding needs of the industrial and commercial markets. They are maintenance free and self-contained.

ACE gas springs remove the need for muscle power and provide controlled motion for lids, hoods, machine guards, panels and more.

Body diameter models are available from 15 mm to 28 mm with forces ranging from 10 N to 2,500 N.

ACE Controls gas springs offer a high service life with treated steel piston rod and precision steel body. In addition, these durable models offer an integrated low friction bearing with a grease chamber that provides a very low break away force. These unique features make the ACE Controls gas springs superior to conventional gas springs.

They can be mounted in any orientation, although mounting with the rod in the downward position is preferred. The internal valve allows the force to be adjusted to your specific requirements.

A wide variety of end fittings make installation easy and versatile.

Self-Contained

Maintenance Free

Treated Steel Rod

Precision Steel Body

Variety of End Fittings



***Aerospace • Defense • Transportation • RV
Medical • Furniture • Packaging • Printing
Amusement and More***

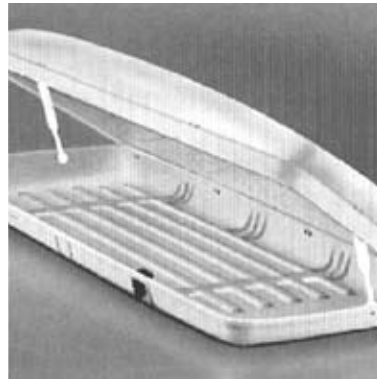

Additional Gas Spring Applications Include:

Computers
Photocopiers
Aircraft Overhead Compartments
Aircraft Galley Equipment
Truck Engine Covers
Truck Side Panels
Electrical Enclosure Cabinets

Boat Engine Hatches
Bus/Coach Engine Covers
Bus/Coach Courier Seats
Fork Lifts
Conveyor Belt Tensioning
Roof Ventilation Hatches
Manhole/Access Covers

Molding Machines
Executive Desks
Smoke Vents
Stair Lifts
Security Cabinets
Washing Machine Lids
Automatic Cash Dispensers

Function

In every action involving a lifting or lowering motion, e.g. when opening a hatch lid, there are moving masses which must be controlled.

If this is ignored, then the kinetic energy caused by the moving mass in motion can result in considerable damage. There are several ways that ACE Controls offers to control this motion.

- a) **Shock absorbers** - used when no return assistance is required and no restriction of the velocity is required. Control is provided shortly before the mechanical components make contact.
- b) **Velocity controls** - used when no return assistance is required, and control of velocity throughout the motion is required.
- c) **Gas springs** - used when return assistance or load support (counterbalance) is required throughout the motion.

On the extension stroke of the gas spring, for example when opening a car tailgate, the nitrogen gas flows through the metering orifice in the piston to provide a controlled opening speed and the oil zone provides damping at the fully open position to avoid impact damage.

The gas spring should be mounted rod down for this damping to be effective. On closing the tailgate the gas spring helps support the weight

Gas springs can be provided in a wide range of body sizes and stroke lengths. The force provided can be specified to suit the specific application. The extension velocity can also be customized on request.

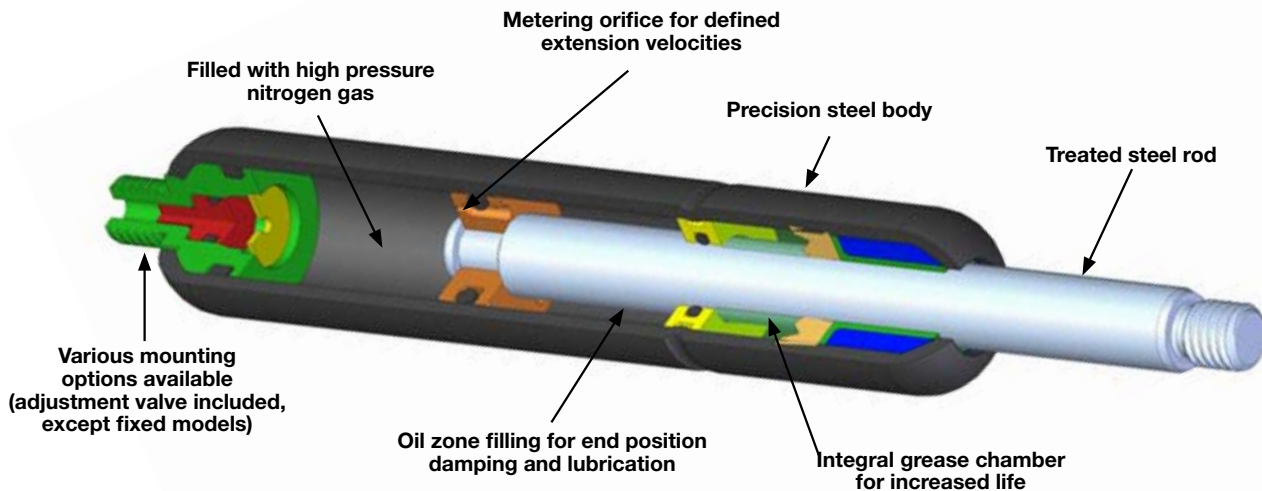

Construction and Operation

ACE Controls gas springs are maintenance free self-contained systems which are filled with high pressure nitrogen gas to a defined force. They also contain a small quantity of oil to provide end position damping.

During operation, the nitrogen gas flows through the metering orifice and allows the load to be lowered in a controlled manner. The force of the gas spring works against the weight and prevents it from accelerating and damaging mechanical components on closure.

Upon reversal, the nitrogen flows back through the piston orifice and the gas spring force assists the action, reducing the effort required to reset the mechanism.

The extension speed can be varied by altering the size of the metering orifice.

For cushioning at the end of the extension stroke, mount with the rod down. For cushioning at the end of the compression stroke, mount with the rod up.

An integral grease chamber behind the rod seals ensures lasting lubrication which can increase the life of ACE Controls gas springs by at least 100% compared to other products on the market.

The treated steel rod and coated precision steel body offer excellent corrosion protection and provide a long maintenance free working life.

The wide variety of available mounting accessories provide mounting versatility and options.

Safety note: if very high demands are placed on durability and stability, please avoid the combination of small diameter + long stroke + high force.

Calculations

In order to save time we recommend that the calculation and selection of the most suitable gas spring be completed by ACE Controls.

With our sophisticated selection software we can quickly determine the resultant opening or closing forces throughout the complete movement and recommend the optimum mounting points, gas spring model and nominal force.

Please fax the completed Application Data form on page 100 to 248-476-2470.

Use the following application parameters to calculate a suitable ACE Controls gas spring:

1. Weight of the lid or flap lbs (kg)
2. Position of the center of gravity in (mm)
3. Sketch of the application layout

Symbols used:

- | | | |
|-------|-----------------------------------|----------|
| W | Force due to weight of the lid | lbs (kg) |
| R_w | Radius of center of gravity | in (mm) |
| L_g | Distance to gas spring | in (mm) |
| s | Center of gravity | - |
| D | Pivot point | - |
| n | Number of gas springs in parallel | - |

Basic formula for calculating required extension force:

$$F_1 = \frac{W \cdot R_w}{L_g \cdot n} \text{ lbs (N)}$$

The basic formula given enables an approximate calculation of the required gas spring force for one mounting position geometry.

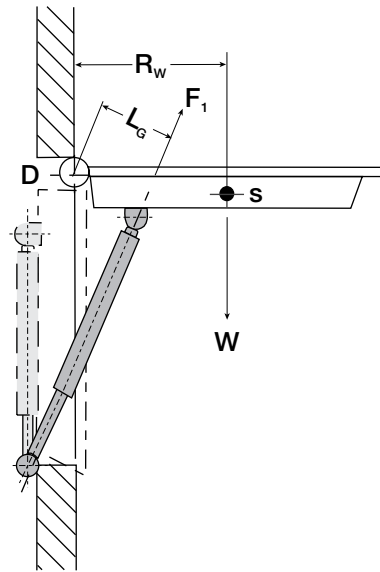

Example

W = 90 lbs (41 kg)
 R_w = 30 in (762 mm)
 L_g = 6 in (152.4 mm)
 n = 2
 $F_1 = \frac{90 \cdot 30}{6 \cdot 2}$
 $F_1 = 225 \text{ lbs (1000 N)}$

Chosen force:

$F_1 = 225 \text{ lbs (1000 N)}$
 Chosen gas spring:
 GS-22-200-AA-1000

Mounting Instructions

ACE Controls gas springs are self contained, maintenance free devices and are supplied ready for installation.

The following points should be noted to ensure the longest possible working life:

Gas spring force F_1 : Gas springs are filled with nitrogen at very high pressures and under no circumstances should they be opened or subjected to excessive tensile loads.

External force F_H : for example manual (hand) force to close the flap.

Weight force W: due to mass acting at center of gravity.

Gas spring orientation as desired:
With piston rod downward – damping effective at end of extension stroke.
With piston rod upward – damping effective at end of compression stroke.

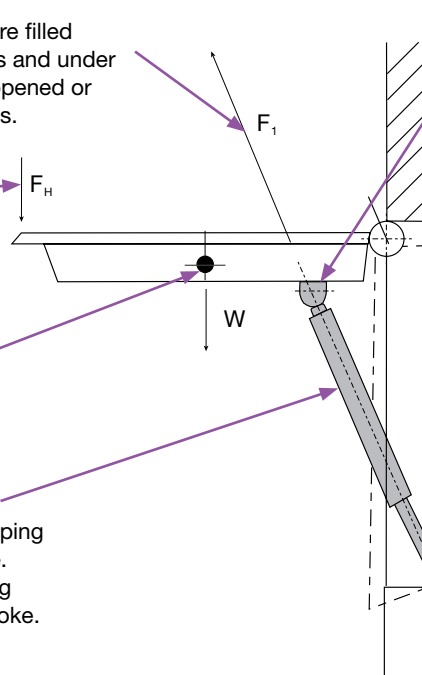

Choose a standard available gas spring from the ACE Controls range featured in this catalog before determining the mounting position coordinates, or preferably allow ACE Controls to do the calculations and provide a printout suggesting the most suitable model and mounting positions.

Where possible arrange the mounting positions so that the effective torque provided by the gas spring positively holds the flap in its closed position.

Protect the rod from impact damage, scratches, dirt or paint contamination. The gas spring body must not be deformed or damaged.

The gas spring must not be exposed to bending forces or side loads. If using eyelet fittings support the eye on both sides and allow some float. We recommend using ball joints on most applications as these help to eliminate misalignment.

Gas Spring Force – Stroke Characteristics Gas Springs – Push Type

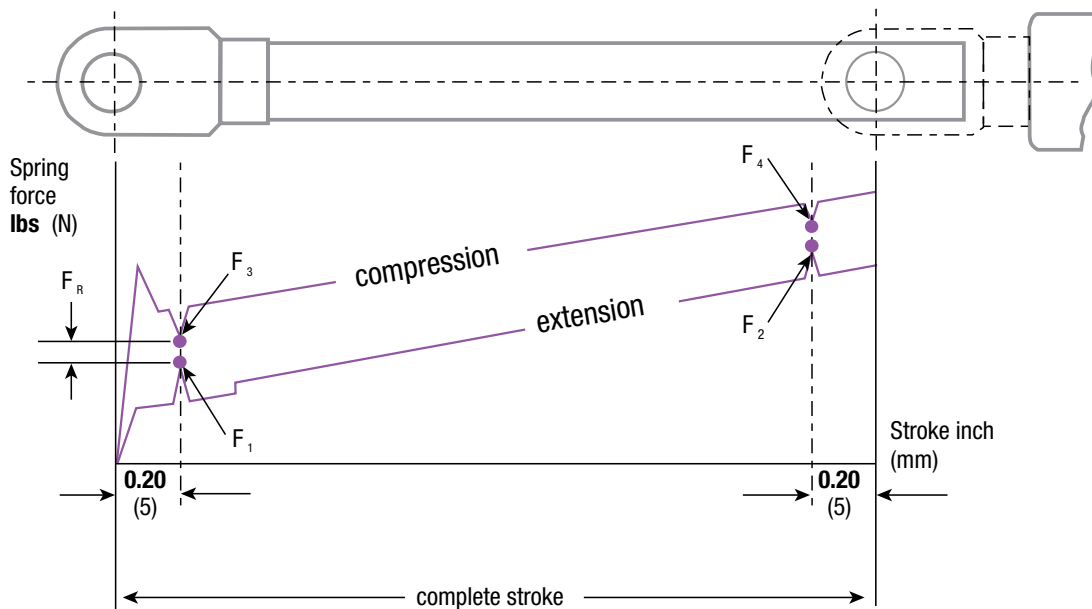

F_1 = Nominal Force at 68° F (20° C) (this figure is normally used when specifying gas springs)

F_2 to F_1 = Force on extension stroke

F_3 to F_4 = Force on compression stroke

Model	Progression ¹ approximate %
A GS-15	27
A GS-19	39-41 ²
A GS-22	52-56 ²
A GS-28	82-87 ²

¹ The progression (slope of the force line in the characteristic diagram above) is due to the reduction of the internal gas volume as the rod moves from its initial position to its fully stroked position.

² Depending on stroke

Effect of temperature: The nominal F_1 force figure is given at 68° F (20° C).

An increase in temperature of 18° F or 10° C will result in approximately a 3.4% increase in the force.

General extension force tolerance is \pm 7%.

Note: Initial breakaway force may be higher if units are stored for a long period without use.

Additional Gas Spring Available Options

1. Gas spring (push type): AGS-40
2. Gas springs (pull type): AGZ-19, AGZ-28 (AGZ models are a special order)

Note: AGS-15 to 40 and AGZ-19 & 28 gas springs are available as fixed force options with optional lengths.

Dimensions in inches and (mm)

Extension force range 2 to 90 lbs (10 to 400 N)

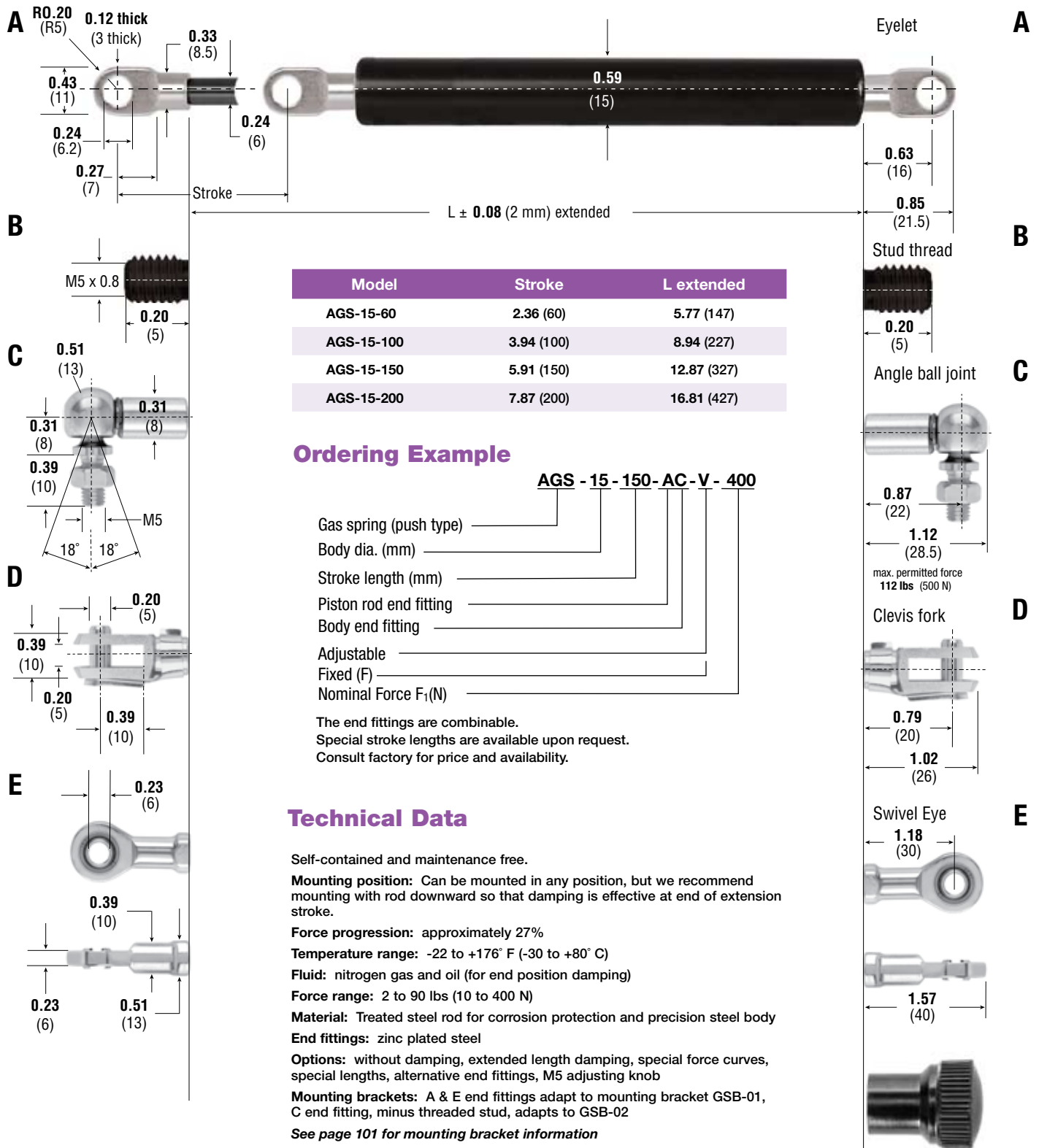

Model	Stroke	L extended
AGS-15-60	2.36 (60)	5.77 (147)
AGS-15-100	3.94 (100)	8.94 (227)
AGS-15-150	5.91 (150)	12.87 (327)
AGS-15-200	7.87 (200)	16.81 (427)

Ordering Example

AGS - 15 - 150 - AC - V - 400

- Gas spring (push type) _____
- Body dia. (mm) _____
- Stroke length (mm) _____
- Piston rod end fitting _____
- Body end fitting _____
- Adjustable _____
- Fixed (F) _____
- Nominal Force $F_1(N)$ _____

The end fittings are combinable.
 Special stroke lengths are available upon request.
 Consult factory for price and availability.

Technical Data

- Self-contained and maintenance free.
- Mounting position:** Can be mounted in any position, but we recommend mounting with rod downward so that damping is effective at end of extension stroke.
- Force progression:** approximately 27%
- Temperature range:** -22 to +176° F (-30 to +80° C)
- Fluid:** nitrogen gas and oil (for end position damping)
- Force range:** 2 to 90 lbs (10 to 400 N)
- Material:** Treated steel rod for corrosion protection and precision steel body
- End fittings:** zinc plated steel
- Options:** without damping, extended length damping, special force curves, special lengths, alternative end fittings, M5 adjusting knob
- Mounting brackets:** A & E end fittings adapt to mounting bracket GSB-01, C end fitting, minus threaded stud, adapts to GSB-02

See page 101 for mounting bracket information
Caution: attempting to adjust gas springs without the proper factory approved adjustment knob could result in serious harm or injury.

Optional M5 adjustment knob for adjusting gas pressure on adjustable models only

Extension force range 11 to 157 lbs (50 to 700 N)

Dimensions in inches and (mm)

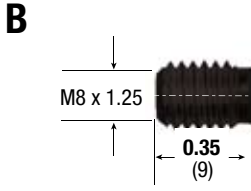
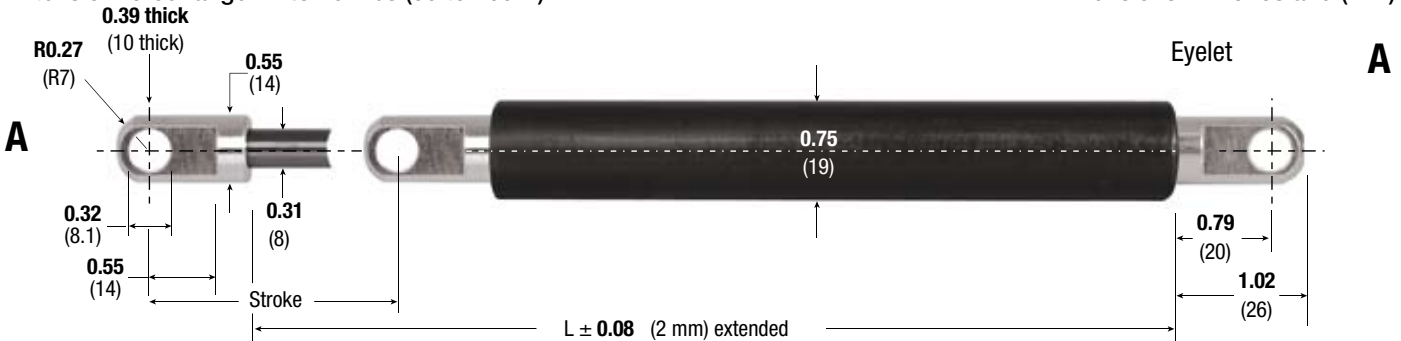

Model	Stroke	L extended
AGS-19-100	3.94 (100)	10.39 (264)
AGS-19-150	5.91 (150)	14.33 (364)
AGS-19-200	7.87 (200)	18.27 (464)
AGS-19-250	9.84 (250)	22.20 (564)

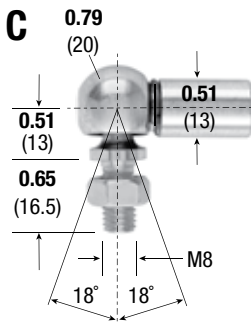

Ordering Example

AGS - 19 - 150 - AC - V - 700

- Gas spring (push type) _____
- Body dia. (mm) _____
- Stroke length (mm) _____
- Piston rod end fitting _____
- Body end fitting _____
- Adjustable _____
- Fixed (F) _____
- Nominal Force F₁(N) _____

The end fittings are combinable.
Special stroke lengths are available upon request.
Consult factory for price and availability.

Technical Data

Self-contained and maintenance free.

Mounting position: Can be mounted in any position, but we recommend mounting with rod downward so that damping is effective at end of extension stroke.

Force progression: approximately 39-41%

Temperature range: -22 to +176°F (-30 to +80°C) with special seals up to +392° F (+200° C)

Fluid: nitrogen gas and oil (for end position damping)

Force range: 11 to 157 lbs (50 to 700 N)

Material: Treated steel rod for corrosion protection and precision steel body

End fittings: zinc plated steel

Options: without damping, extended length damping, special force curves, special lengths, alternative end fittings, M8 adjusting knob

Mounting brackets: A end fitting adapts to mounting brackets GSB-03, GSB-04 and GSB-05, C end fitting, minus threaded stud, adapts to GSB-06

See page 101 for mounting bracket information

Caution: attempting to adjust gas springs without the proper factory approved adjustment knob could result in serious harm or injury.

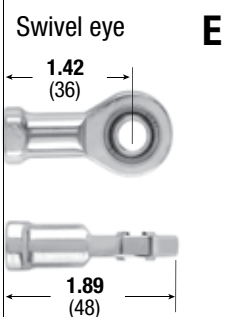
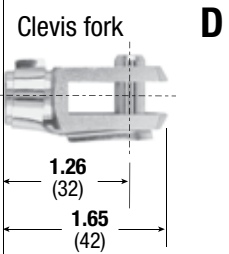
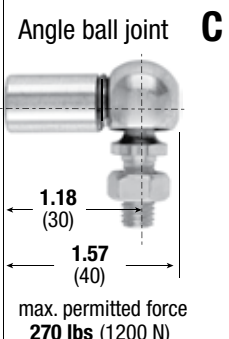
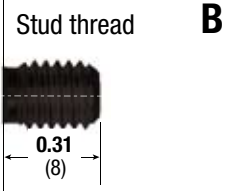

Optional M8 adjustment knob for adjusting gas pressure on adjustable models only

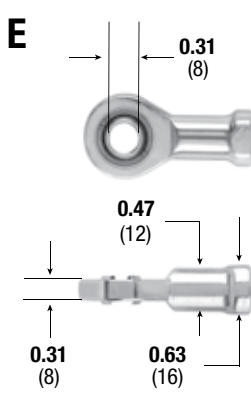
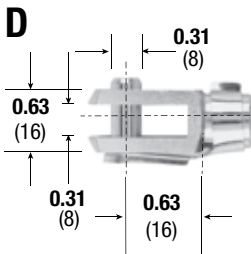

Dimensions in inches and (mm)

Extension force range 18 to 292 lbs (80 to 1,300 N)

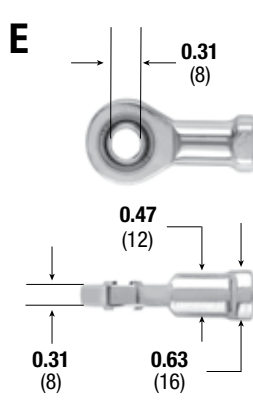
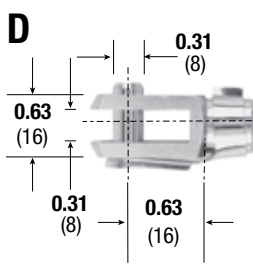
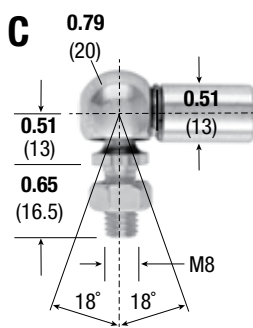
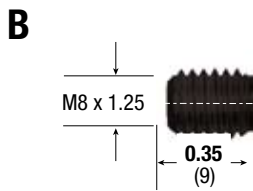
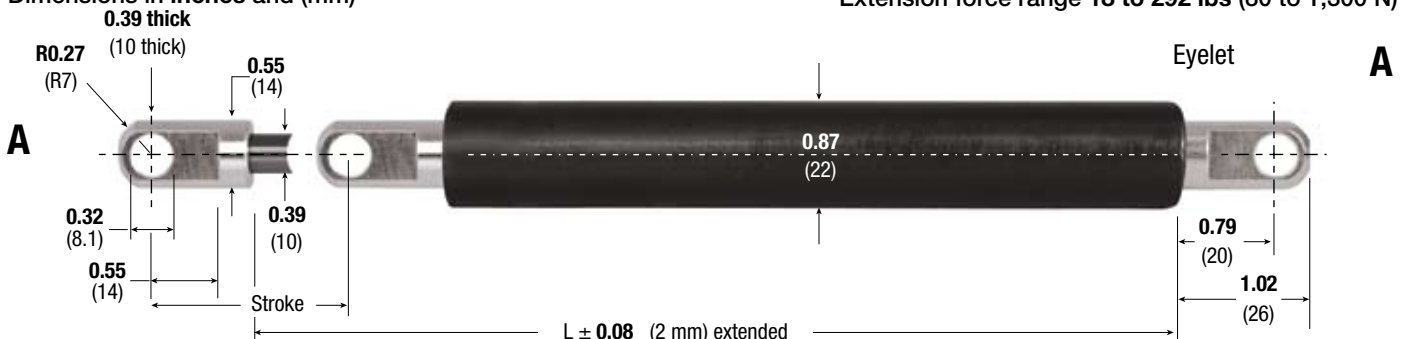

Model	Stroke	L extended
AGS-22-100	3.94 (100)	10.39 (264)
AGS-22-200	7.87 (200)	18.27 (464)
AGS-22-250	9.84 (250)	22.20 (564)
AGS-22-300	11.81 (300)	26.14 (664)
AGS-22-400	15.75 (400)	34.02 (864)

Ordering Example

AGS - 22 - 250 - AB - V - 1300

- Gas spring (push type) _____
- Body dia. (mm) _____
- Stroke length (mm) _____
- Piston rod end fitting _____
- Body end fitting _____
- Adjustable _____
- Fixed (F) _____
- Nominal Force F1(N) _____

The end fittings are combinable.
 Special stroke lengths are available upon request.
 Consult factory for price and availability.

Technical Data

- Self-contained and maintenance free.
- Mounting position:** Can be mounted in any position, but we recommend mounting with rod downward so that damping is effective at end of extension stroke.
- Force progression:** approximately 52-56%
- Temperature range:** -22 to +176° F (-30 to +80° C) with special seals up to +392° F (+200° C)
- Fluid:** nitrogen gas and oil (for end position damping)
- Force range:** 18 to 292 lbs (80 to 1300 N)
- Material:** Treated steel rod for corrosion protection and precision steel body
- End fittings:** zinc plated steel
- Options:** without damping, extended length damping, special force curves, special lengths, alternative end fittings, M8 adjusting knob
- Mounting brackets:** A end fitting adapts to mounting brackets GSB-03, GSB-04 and GSB-05, C end fitting, minus threaded stud, adapts to GSB-06.
- See page 101 for mounting bracket information**
- Caution:** attempting to adjust gas springs without the proper factory approved adjustment knob could result in serious harm or injury.

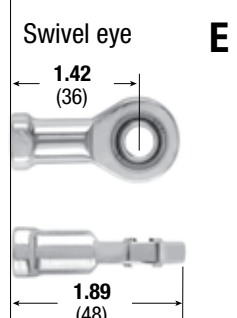
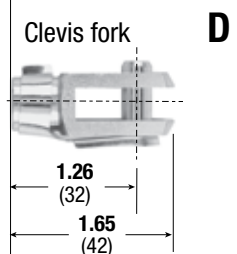
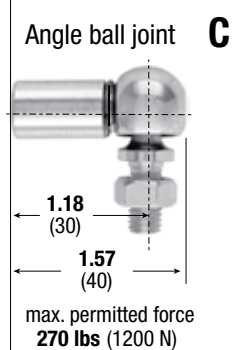
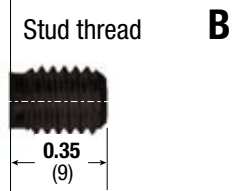

Optional M8 adjustment knob for adjusting gas pressure on adjustable models only

Extension force range 34 to 562 lbs (150 to 2,500 N)

Dimensions in inches and (mm)

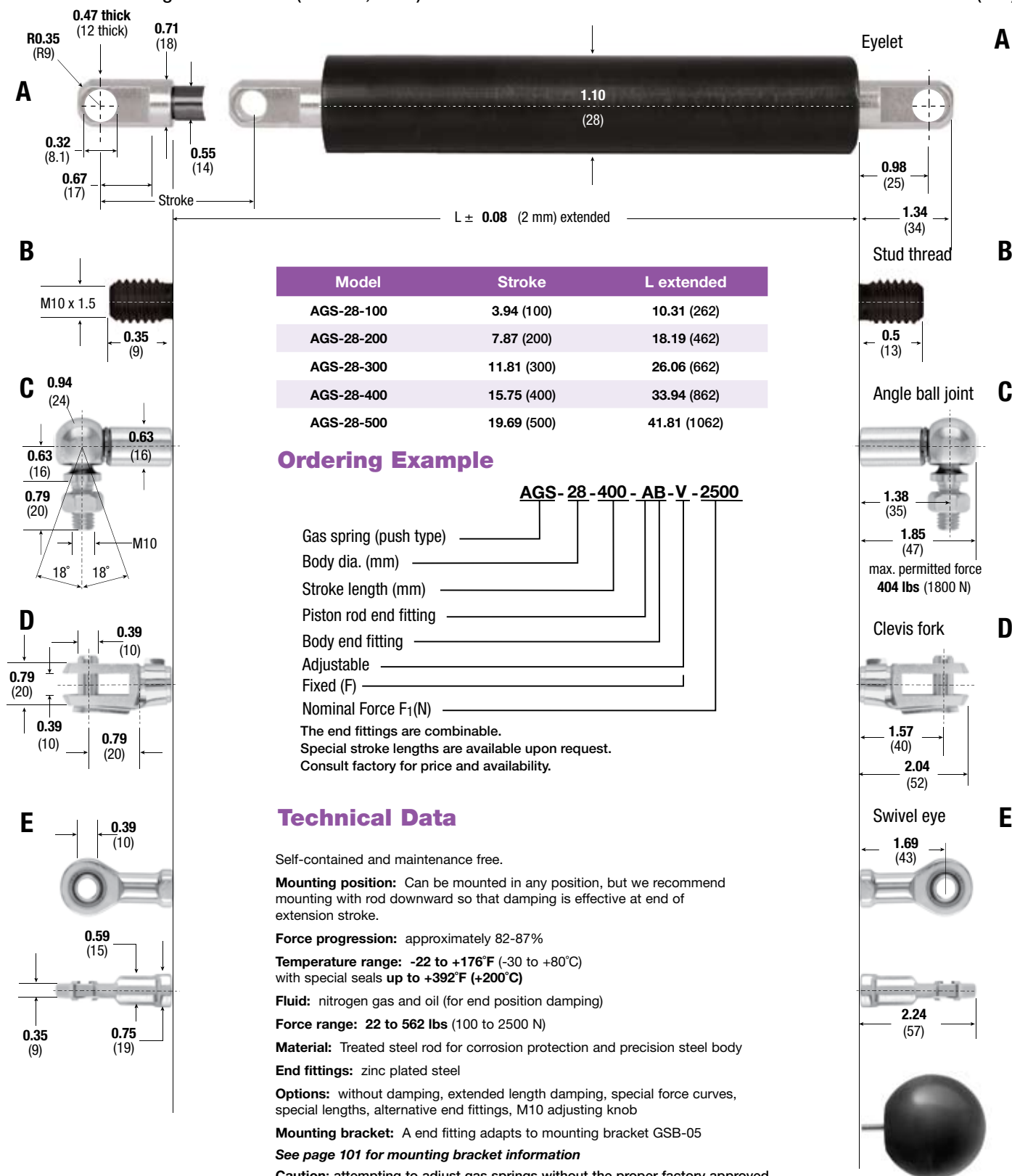

Model	Stroke	L extended
AGS-28-100	3.94 (100)	10.31 (262)
AGS-28-200	7.87 (200)	18.19 (462)
AGS-28-300	11.81 (300)	26.06 (662)
AGS-28-400	15.75 (400)	33.94 (862)
AGS-28-500	19.69 (500)	41.81 (1062)

Ordering Example

AGS-28-400-AB-V-2500

- Gas spring (push type)
- Body dia. (mm)
- Stroke length (mm)
- Piston rod end fitting
- Body end fitting
- Adjustable
- Fixed (F)
- Nominal Force $F_1(N)$

The end fittings are combinable.
 Special stroke lengths are available upon request.
 Consult factory for price and availability.

Technical Data

Self-contained and maintenance free.

Mounting position: Can be mounted in any position, but we recommend mounting with rod downward so that damping is effective at end of extension stroke.

Force progression: approximately 82-87%

Temperature range: -22 to +176°F (-30 to +80°C)
 with special seals up to +392°F (+200°C)

Fluid: nitrogen gas and oil (for end position damping)

Force range: 22 to 562 lbs (100 to 2500 N)

Material: Treated steel rod for corrosion protection and precision steel body

End fittings: zinc plated steel

Options: without damping, extended length damping, special force curves, special lengths, alternative end fittings, M10 adjusting knob

Mounting bracket: A end fitting adapts to mounting bracket GSB-05

See page 101 for mounting bracket information

Caution: attempting to adjust gas springs without the proper factory approved adjustment knob could result in serious harm or injury.

Optional M10 adjustment knob for adjusting gas pressure on adjustable models only

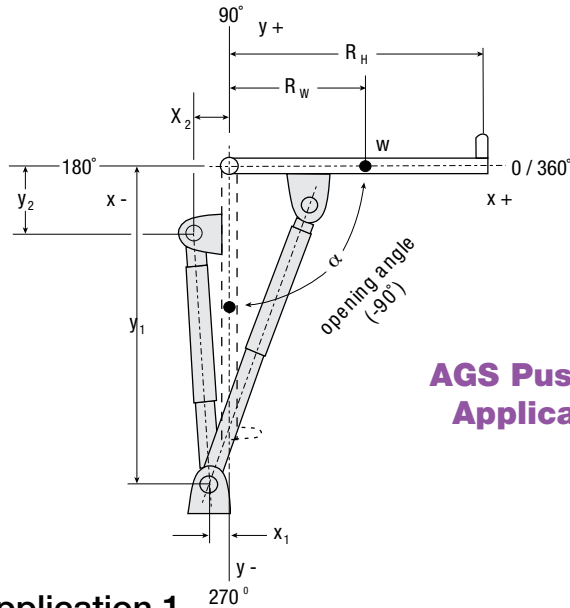

AGS Push Type Applications

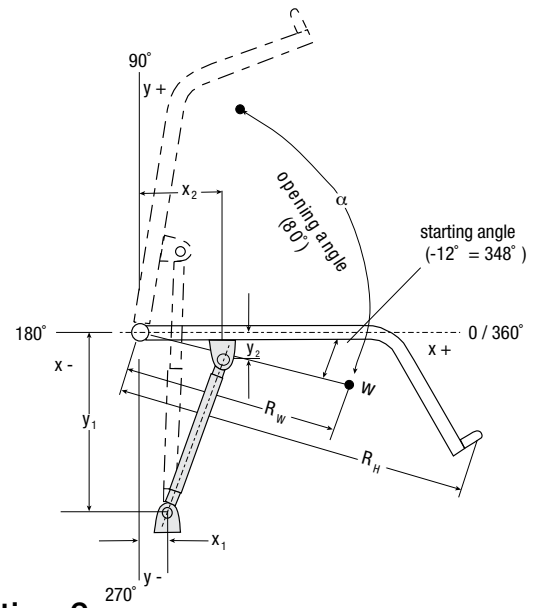

Application 1

Application 2

Requirement per year _____

Name _____

Company _____

Address _____

Telephone _____

Fax _____

E-mail _____

Comments _____

Gas Spring Type

Input Data

Radius of center of gravity R_W _____ in (mm)

Moving weight w _____ lbs (kg)

Radius of hand force R_H _____ in (mm)

Desired max. handforce F_H _____ lbs (N)

Number of gas springs in parallel n _____ pcs

Starting angle (0 to 360°) _____ °

Opening angle (-360 to +360°) _____ °

Gas spring fixing points (complete if desired)

Fixed point (x-coord.) x_1 _____ in (mm)

Fixed point (y-coord.) y_1 _____ in (mm)

Moving point (x-coord.) x_2 _____ in (mm)

Moving point (y-coord.) y_2 _____ in (mm)

Desired End Fittings

- | | | |
|----------------------------|------------------|----------------------------|
| <input type="checkbox"/> A | Eyelet | <input type="checkbox"/> A |
| <input type="checkbox"/> B | Stud thread | <input type="checkbox"/> B |
| <input type="checkbox"/> C | Angle ball joint | <input type="checkbox"/> C |
| <input type="checkbox"/> D | Clevis fork | <input type="checkbox"/> D |
| <input type="checkbox"/> E | Swivel Eye | <input type="checkbox"/> E |

**PLEASE FAX TO: ACE CONTROLS
APPLICATIONS ENGINEERING AT
248-476-2470**

Mounting Brackets for Gas Springs & Hydraulic Dampers

Dimensions in inches and (mm)

Material: zinc plated steel

GSB-01

max. force **112 lbs** (500 N)

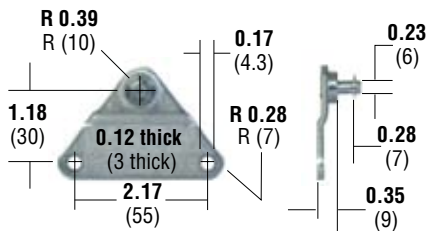

Snap ring included

GSB-02

max. force **112 lbs** (500 N)

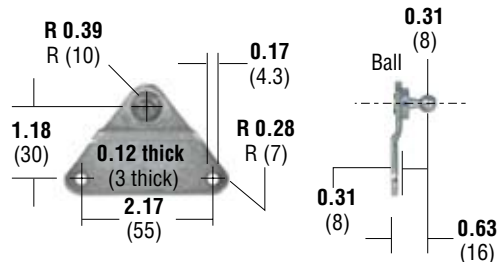

GSB-03

max. force **270 lbs** (1200 N)

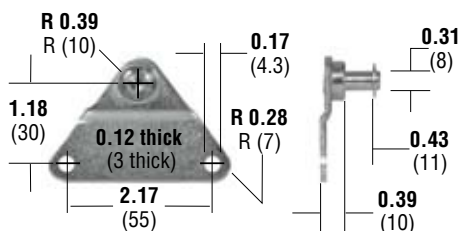

Snap ring included

GSB-04

max. force **270 lbs** (1200 N)

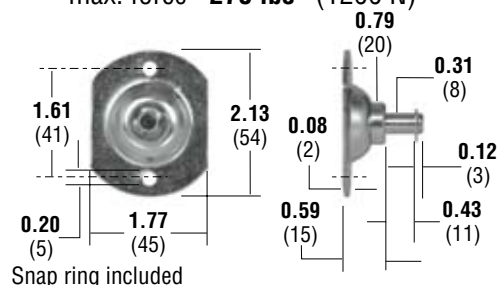

Snap ring included

GSB-05

max. force **405 lbs** (1800 N)

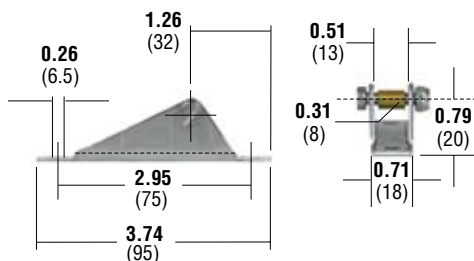

Bolt, nut, spacer included

GSB-06

max. force **270 lbs** (1200 N)

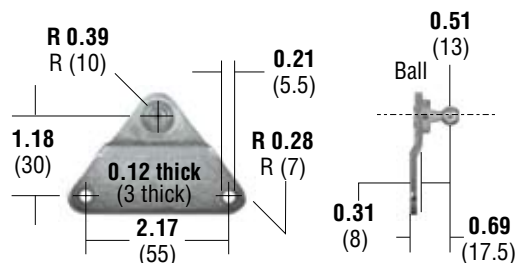

Note: Rising force curve on compression for gas springs.

ME14

max. force **2,248 lbs** (10,000 N)

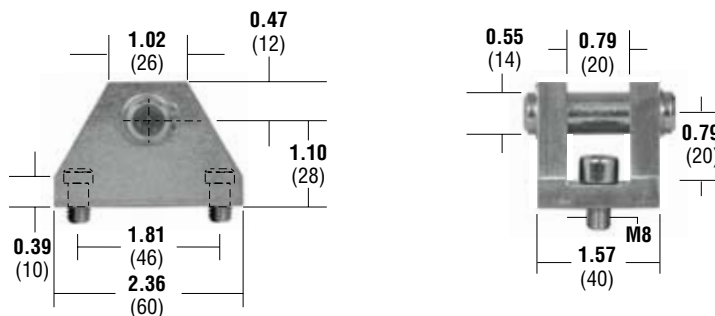

See individual model pages for specific information on the correct end fittings for each mounting bracket.

Mounting brackets are identical to those on page 112.