

Power Supply



6.1 General Purpose and Sensor Power Supplies

Product Selection Guide	V7-T6-2
PSG Series	V7-T6-3
PSS Series	V7-T6-8
ELC Series	V7-T6-12
EZ Power Supply	V7-T6-15
Sensor Power Supply	V7-T6-18

6.1

Power Supplies

General Purpose and Sensor Power Supplies

Power Supplies



6

Contents

Description

Page

General Purpose and Sensor Power Supplies	
PSG Series	V7-T6-3
PSS Series	V7-T6-8
ELC Series	V7-T6-12
EZ Power Supply	V7-T6-15
Sensor Power Supply	V7-T6-18

Product Selection Guide

Power Supply Series and Features



PSG



PSS



ELC



EZ Power Series



Sensor Power Supplies

	PSG	PSS	ELC	EZ Power Series	Sensor Power Supplies
Features	General purpose 24 Vdc control Rugged metal housing DIN rail mount 150% current boost for 1 sec (outrush) Single-phase (85–264 Vac/120–375 Vdc) or three-phase (320–575 Vac/450–800 Vdc) inputs Class 1, Division 2 qualified (February 2009) Conformal coated electronics	24 Vdc control for high startup loads Peak current surge (boost/outrush) up to 6 times nominal current Semi 47 approved Long ride-through capability Pluggable terminal connections Single-phase and three-phase inputs up to 600 Vac	Compact, low cost 24 Vdc control for loads up to 2A Plastic enclosure can be DIN rail or panel mounted Class 1, Division 2 qualified Single-phase (85–264 Vac) input	Shallow-depth power supplies for 12 Vdc or 24 Vdc applications Low-power output—up to 1.25A EZ Relay styling provides optimal panel aesthetics Plastic enclosure can be DIN rail or panel mounted (with optional kit) Class 1, Division 2 qualified Single-phase (85–264 Vac) input	27 Vdc supplies for tough sensor applications Rugged housings with integrated junction box for mounting outside of electrical enclosures Advanced diagnostic features
Product Selection	Page V7-T6-4	Page V7-T6-9	Page V7-T6-13	Page V7-T6-16	Page V7-T6-19
Technical Data and Specifications	Page V7-T6-4	Page V7-T6-10	Page V7-T6-13	Page V7-T6-16	Page V7-T6-19
Dimensions	Page V7-T6-6	—	Page V7-T6-14	Page V7-T6-17	Page V7-T6-20

PSG Series



Contents

Description	Page
PSG Series	
Product Selection	V7-T6-4
Technical Data and Specifications	V7-T6-4
Power Derating Curves	V7-T6-5
Dimensions	V7-T6-6
PSS Series	V7-T6-8
ELC Series	V7-T6-12
EZ Power Supply	V7-T6-15
Sensor Power Supply	V7-T6-18

PSG Series

Product Description

Eaton’s PSG Series of power supplies is designed to be a high-performance, high-quality line of products covering a majority of 24 Vdc control applications. With global certifications, compact size and an impressive operating temperature range, the PSG Series fits a wide variety of applications at a competitive price.

Eight models are offered, from 2.5A up to 20A with both single- and three-phase input voltage models available.

Application Description

The PSG Series is a line of general-purpose power supplies for use in a wide variety of industrial control applications. Applications include communication networks, sensors, PLCs and many other electrical systems.

Each model is equipped with a rugged metal housing, heavy-duty screw terminals and a variety of protection features, making the PSG one of the most versatile industrial power supply lines on the market.

Features, Benefits and Functions

- Universal input voltages: 85–264 Vac for single-phase units, 320–575 Vac for three-phase units
- Rugged aluminum housing stands up to harsh environments
- Current surge (power boost) of 1.5 times nominal current for 1 second allows branch protection and powering of high pickup loads
- Wide operating temperature range: –20°C to +75°C (derating above 50°C)
- Adjustable DC voltage output
- LED indicating light for DC OK simplifies troubleshooting
- Compact size, with common depth and height across all models, allows for common panel depths and family consistency
- MTBF up to 800,000 hours ensures uptime and reliability
- Heavy-duty screw terminals with finger-safe protective cover allow use of ring-lug terminals
- All-metal DIN rail mounting hardware
- Class 1, Division 2 hazardous location rated

Standards and Certifications

- UL/cUL listed—UL 508 (industrial control equipment)
- cURus—UL 60950-1
- IEC
- EN
- German safety
- CSA certified (contact Eaton for certification dates and status)
- CE marked
- RoHS compliant



Product Selection

PSG60E



Power Supply—Single-Phase

	Catalog Number
85–264 Vac input, 24 Vdc/2.5A output	PSG60E
85–264 Vac input, 24 Vdc/5A output	PSG120E
85–264 Vac input, 24 Vdc/10A output	PSG240E
85–264 Vac input, 24 Vdc/20A output	PSG480E

Power Supply—Three-Phase

	Catalog Number
320–575 Vac input, 24 Vdc/2.5A output	PSG60F
320–575 Vac input, 24 Vdc/5A output	PSG120F
320–575 Vac input, 24 Vdc/10A output	PSG240F
320–575 Vac input, 24 Vdc/20A output	PSG480F

Technical Data and Specifications

PSG Series

Capacity	PSG60E 60W	PSG120E 120W	PSG240E 240W	PSG480E 480W	PSG60F 60W	PSG120F 120W	PSG240F 240W	PSG480F 480W
Input								
Nominal voltage	100–240 Vac	100–240 Vac	100–240 Vac	100–240 Vac	3 x 400–500 Vac	3 x 400–500 Vac	3 x 400–500 Vac	3 x 400–500 Vac
Voltage range	②	②	②	②	③	③	③	③
Frequency	47–63 Hz (0 Hz at DC input)	47–63 Hz (0 Hz at DC input)	47–63 Hz (0 Hz at DC input)	47–63 Hz (0 Hz at DC input)	47–63 Hz (0 Hz at DC input)	47–63 Hz (0 Hz at DC input)	47–63 Hz (0 Hz at DC input)	47–63 Hz (0 Hz at DC input)
Nominal current ①	1.1A	1.4A	2.9A	5.7A	0.3A	0.5A	0.8A	1.6A
Inrush current limitation ①	30A	<80A	N/A	N/A	<30A	<30A	<40A	<50A
Mains buffering at nominal load (typ.) ①	>20 ms	>35 ms	>20 ms	>20 ms	>30 ms	>35 ms	>35 ms	>20 ms
Turn-on time	<2.5 sec	<1 sec	<1 sec	<1 sec	<2 sec	<1 sec	<1 sec	<1 sec
Internal fuse	T3.15 AH/250V	T3.15 AH/250V	T6.3AH/250V	F10H/250V	3.15AH/500V	3.15AH/500V	3.15AH/500V	3.15AH/500V
External fusing	6A, 10A or 16A	6A, 10A or 16A	10A or 16A	10A or 16A	3 x circuit breakers 6A, 10A or 16A	3 x circuit breakers 6A, 10A or 16A	3 x circuit breakers 6A, 10A or 16A	3 x circuit breakers 6A, 10A or 16A
Leakage current	<1 mA	<1 mA	<3.5 mA	<1 mA	<3.5 mA	<3.5 mA	<3.5 mA	<3.5 mA
Output								
Nominal output voltage	24 Vdc ± 2%	24 Vdc ± 2%	24 Vdc ± 2%	24 Vdc ± 2%	24 Vdc ± 2%	24 Vdc ± 2%	24 Vdc ± 2%	24 Vdc ± 2%
Adjustment range	22–28 Vdc	22–28 Vdc	22–28 Vdc	22–28 Vdc	22–28 Vdc	22–28 Vdc	22–28 Vdc	22–28 Vdc
Nominal current	2.5A	5A	10A	20A	2.5A	5A	10A	20A
Startup with capacitive loads	Max. 8,000 µF	Max. 10,000 µF	Max. 10,000 µF	Max. 10,000 µF	Max. 10,000 µF	Max. 10,000 µF	Max. 10,000 µF	Max. 10,000 µF
Max. power dissipation idling nominal load approx.	10W	22.5W	42.5W	72W	9W	18W	36W	72W
Efficiency (at 400 Vac and nominal values)	>85% typ	>84% typ	>84% typ	>86% typ	>86% at 3 x 400 Vac; >85% at 3 x 500 Vac	>86% at 3 x 400 Vac; >85% at 3 x 500 Vac	>86% at 3 x 400 Vac; >85% at 3 x 500 Vac	>86% at 3 x 400 Vac; >85% at 3 x 500 Vac
Current surge (at 24 Vdc)	3.75A	7.5A	15A	30A	3.75A	7.5A	15A	30A
Current surge time/cycle	1 sec. (at 10-sec. intervals)	1 sec. (at 10-sec. intervals)	1 sec. (at 10-sec. intervals)	1 sec. (at 10-sec. intervals)	1 sec. (at 10-sec. intervals)	1 sec. (at 10-sec. intervals)	1 sec. (at 10-sec. intervals)	1 sec. (at 10-sec. intervals)
Residual ripple/peak switching (20 MHz)	<50 mV/ <240 mVpp	<50 mV/ <240 mVpp	<50 mV/ <240 mVpp	<50 mV/ <240 mVpp	<50 mV/ <240 mVpp	<50 mV/ <240 mVpp	<50 mV/ <240 mVpp	<50 mV/ <240 mVpp
Parallel operation	With O-ring Diode	With O-ring Diode	With O-ring Diode	With O-ring Diode	With O-ring Diode	With O-ring Diode	With O-ring Diode	With O-ring Diode
Galvanic Isolation								
Input/output	4 kVAC (type test)/3 kVAC (routine test)	4 kVAC (type test)/3 kVAC (routine test)	4 kVAC (type test)/3 kVAC (routine test)	4 kVAC (type test)/3 kVAC (routine test)	4 kVAC (type test)/3 kVAC (routine test)	4 kVAC (type test)/3 kVAC (routine test)	4 kVAC (type test)/3 kVAC (routine test)	4 kVAC (type test)/3 kVAC (routine test)
Input/ground	1.5 kVAC (type test)/1.5 kVAC (routine test)	1.5 kVAC (type test)/1.5 kVAC (routine test)	1.5 kVAC (type test)/1.5 kVAC (routine test)	1.5 kVAC (type test)/1.5 kVAC (routine test)	1.5 kVAC (type test)/1.5 kVAC (routine test)	1.5 kVAC (type test)/1.5 kVAC (routine test)	1.5 kVAC (type test)/1.5 kVAC (routine test)	1.5 kVAC (type test)/1.5 kVAC (routine test)
Output/ground	1.5 kVAC (type test)/500 Vac (routine test)	1.5 kVAC (type test)/500 Vac (routine test)	1.5 kVAC (type test)/500 Vac (routine test)	1.5 kVAC (type test)/500 Vac (routine test)	1.5 kVAC (type test)/500 Vac (routine test)	1.5 kVAC (type test)/500 Vac (routine test)	1.5 kVAC (type test)/500 Vac (routine test)	1.5 kVAC (type test)/500 Vac (routine test)

Notes

- ① Ratings for single-phase models are at 115 Vac; three-phase models are at 400 Vac.
- ② 85–264 Vac (DC input range 120–375 Vdc)
- ③ 320–575 Vac (DC input range 450–800 Vdc)

PSG Series, continued

Capacity	PSG60E 60W	PSG120E 120W	PSG240E 240W	PSG480E 480W	PSG60F 60W	PSG120F 120W	PSG240F 240W	PSG480F 480W
General/Physical Data								
Housing material	Aluminum (Al5052)	Aluminum (Al5052)	Aluminum (Al5052)	Aluminum (Al5052)	Aluminum (Al5052)	Aluminum (Al5052)	Aluminum (Al5052)	Aluminum (Al5052)
Signals	Green LED for DC OK	Green LED for DC OK	Green LED for DC OK	Green LED for DC OK	Green LED for DC OK	Green LED for DC OK	Green LED for DC OK	Green LED for DC OK
MTBF	>800,000 hrs	>800,000 hrs	>300,000 hrs	>300,000 hrs	>500,000 hrs	>500,000 hrs	>300,000 hrs	>300,000 hrs
Dimensions (L)	121 mm	121 mm	121 mm	121 mm	121 mm	121 mm	121 mm	121 mm
Dimensions (W)	32 mm	50 mm	85 mm	160 mm	70 mm	70 mm	85 mm	160 mm
Dimensions (H)	120 mm	115 mm	118.5 mm	115 mm	118.5 mm	118.5 mm	120.5 mm	115 mm
Weight (kg)	0.37	0.54	1.04	1.8	0.56	0.72	0.77	1.71
Operating temperature	-20°C to +75°C (>50°C derating)	-20°C to +75°C (>50°C derating)	-20°C to +75°C (>50°C derating)	-20°C to +75°C (>50°C derating)	-20°C to +75°C (>50°C derating)	-20°C to +75°C (>50°C derating)	-20°C to +75°C (>50°C derating)	-20°C to +75°C (>50°C derating)
Storage temperature	-25°C to +85°C	-25°C to +85°C	-25°C to +85°C	-25°C to +85°C	-25°C to +85°C	-25°C to +85°C	-25°C to +85°C	-25°C to +85°C
Operating humidity	<95% RH, noncondensing	<95% RH, noncondensing	<95% RH, noncondensing	<95% RH, noncondensing	<95% RH, noncondensing	<95% RH, noncondensing	<95% RH, noncondensing	<95% RH, noncondensing
Vibration (operating)	①	①	①	①	①	①	①	①
Pollution degree	2	2	2	2	2	2	2	2
Climatic class	3K3 according to EN 60721	3K3 according to EN 60721	3K3 according to EN 60721	3K3 according to EN 60721	3K3 according to EN 60721	3K3 according to EN 60721	3K3 according to EN 60721	3K3 according to EN 60721
Safety and Protection								
Transient surge voltage	Varistor	Varistor	Varistor	Varistor	Varistor	Varistor	Varistor	Varistor
Surge voltage protection against internal surge	Yes	Yes	Yes	Yes	Yes	Yes	Yes	Yes
Safety class	Class I with ground connection	Class I with ground connection	Class I with ground connection	Class I with ground connection	Class I with ground connection	Class I with ground connection	Class I with ground connection	Class I with ground connection
Shock	②	②	②	②	②	②	②	②

Power Derating Curves

Vertical Mounting Position PSG60E

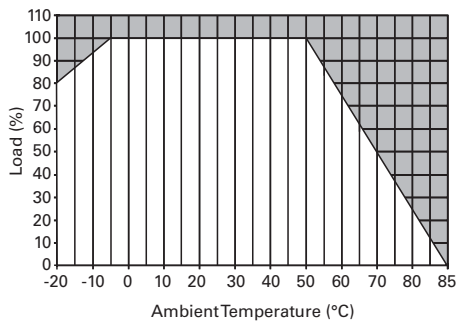

Vertical Mounting Position PSG240E, PSG240F

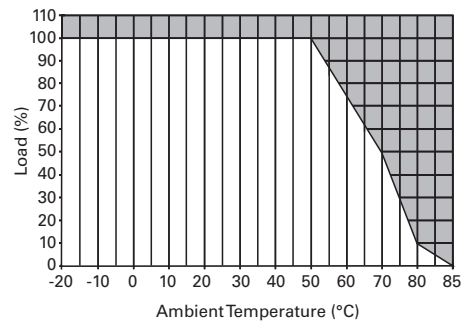

Vertical Mounting Position PSG60F, PSG120E, PSG120F, PSG480E, PSG480F

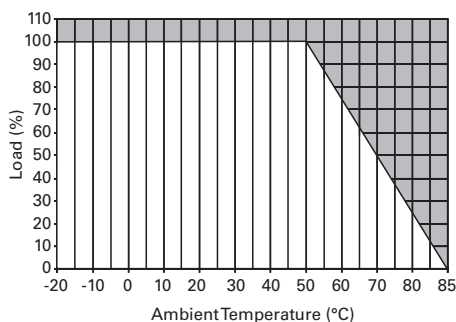

Notes

- ① 10 to 150 Hz, 0.35 mm acc. 50 m/s/s, single amplitude (5G max.) for 90 min. in each X, Y, Z direction, in acc. with IEC 68-2-6.
- ② 30G (300 m/s/s) in all directions according to IEC 68-2-27.

6.1

Power Supplies

General Purpose and Sensor Power Supplies

Dimensions

Approximate Dimensions in mm

Note: Dimensions are for reference only.

PSG60E

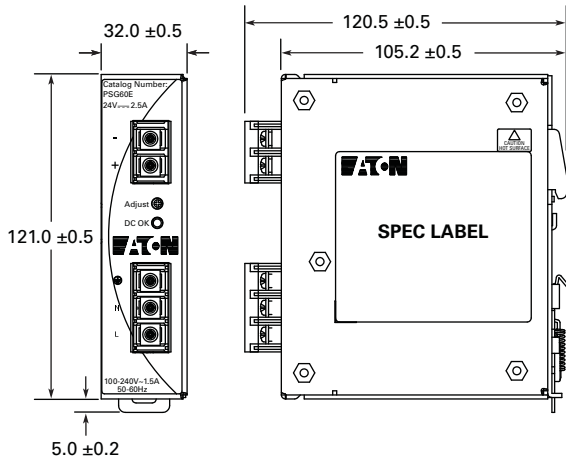

PSG120E

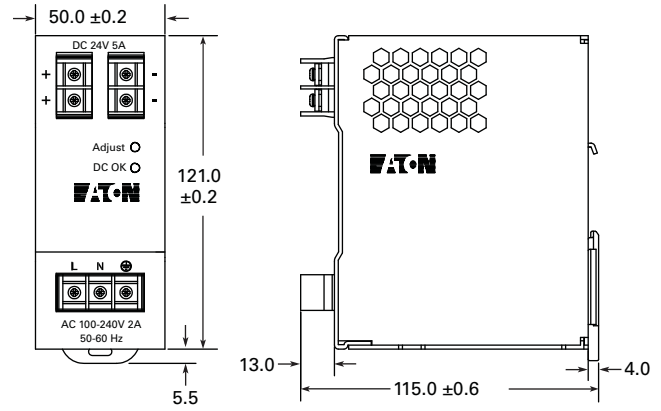

PSG60F

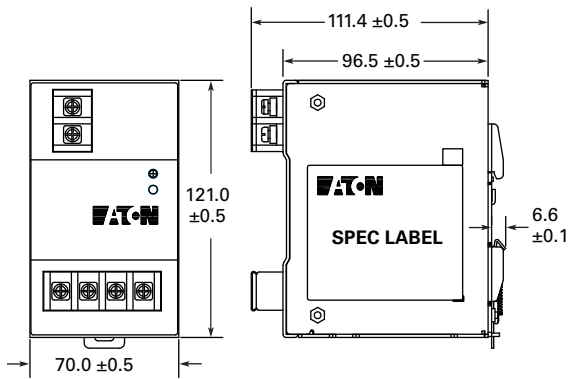

PSG120F

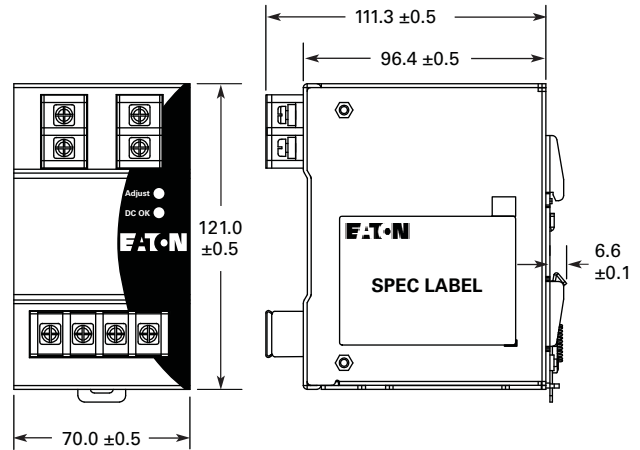

PSG240E

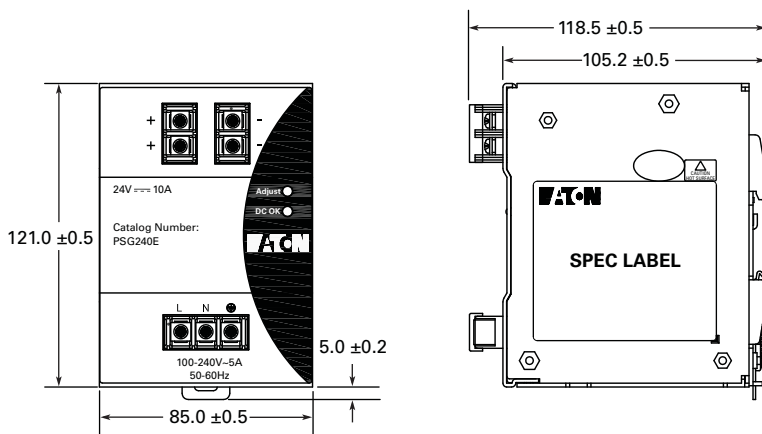

Approximate Dimensions in mm

Note: Dimensions are for reference only.

PSG240F

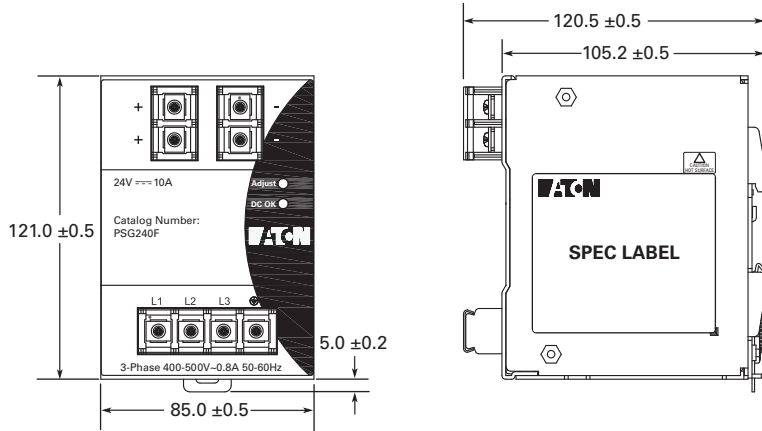

PSG480E

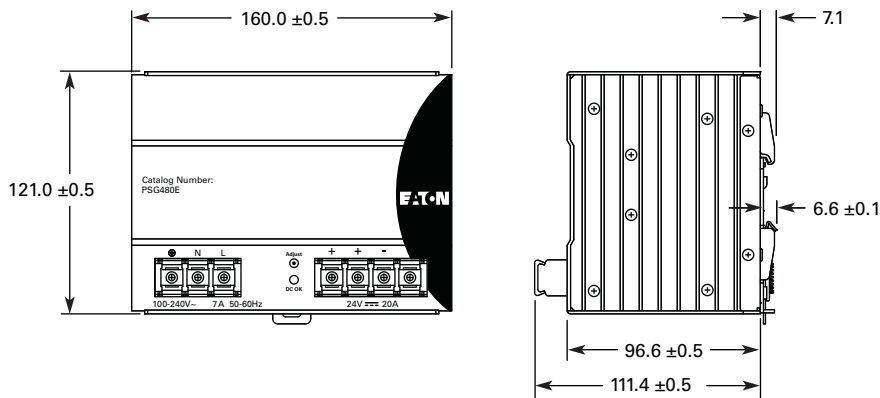

PSG480F

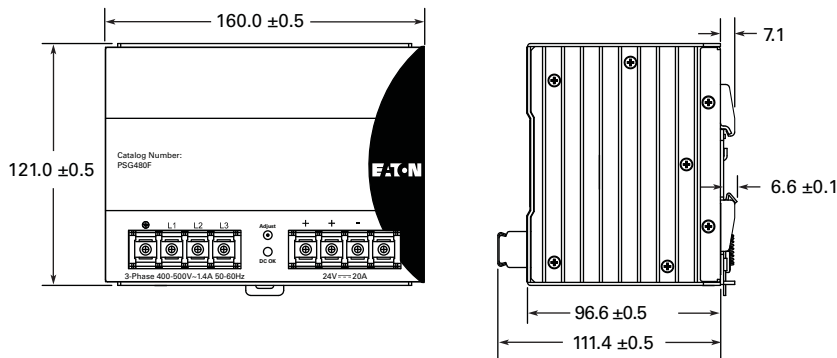

PSS Series



Contents

<i>Description</i>	<i>Page</i>
PSG Series	V7-T6-3
PSS Series	
Catalog Number Selection	V7-T6-9
Product Selection	V7-T6-9
Accessories	V7-T6-9
Technical Data and Specifications	V7-T6-10
ELC Series	V7-T6-12
EZ Power Supply	V7-T6-15
Sensor Power Supply	V7-T6-18

PSS Series

Product Description

Eaton's PSS Series of power supplies is designed to work in a variety of applications, including the power supply to the **IT** line of power control products. They also work in most control applications that require 24 Vdc. All of the PSS power supplies are designed to provide the highest "outrush" current in the industry for units of their size.

Application Description

The PSS line of power supplies is specifically designed to work with the S801, S811, MV811 and **IT** electro-mechanical devices. They can also serve in a variety of other applications, including support of sensors, operator interfaces, PLCs, communication networks, heaters and lights, and in many other industrial applications where 24 Vdc power supplies are required.

Features

- High current outrush capability in all units
- Semiconductor F47 approved
- Long ride-through capability designed in
- Wide operating temperature range
- Multiple 24 Vdc terminals for easy wiring
- Removable terminal connections
- IP20 fingerproof design

Benefits

- 24 Vdc control enhances personnel and equipment safety
- IP20 design improves personnel safety
- Removable terminal connectors make installation and repair quick and easy
- High current outrush capability allows use of smaller power supplies in many applications and ensures stable output during high power demand cycles
- Due to long ride-through time, the power supply can maintain the control power system during brownout and blackout conditions

Standards and Certifications

- UL listed 508
- CSA certified
- CE marked
- F47 certified



Catalog Number Selection

PSS Series Power Supply

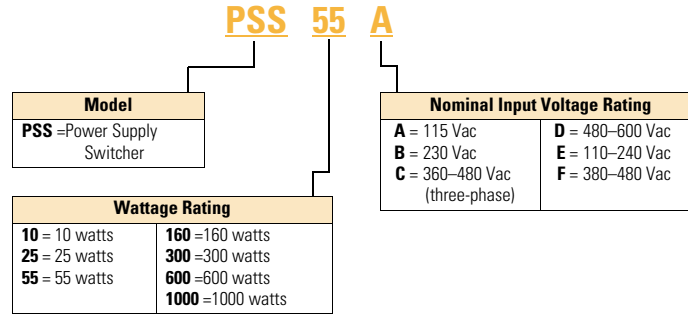

Product Selection

PSS55D



PSS Series Power Supply

Steady-State Current (Amps)	Steady-State Wattage	Input Voltage	Catalog Number
0.4	10W	110–240	PSS10E
		380–480	PSS10F
1	25W	110–240	PSS25E
		380–480	PSS25F
2.3	55W	480–600	PSS55D

PSS Sizing Chart

IEC Size	NEMA Size	Steady-State Current	Inrush Amps	Inrush Duration
A	N/A	0.83A	0.83A	30 ms
B	00, 0	0.13A	3.30A	50 ms
C	1	0.15A	3.80A	50 ms
D	2	0.21A	5.40A	65 ms
E	3, 4	0.23A	5.80A	85 ms
F	5	0.54A	8.30A	250 ms

Accessories

DIN Rail Mounting Kit

Description	Catalog Number
DIN rail mounting	PSSDIN

Technical Data and Specifications

PSS Series, PSS10E–PSS55D

Capacity	PSS10E 10W	PSS10F 10W	PSS25E 25W	PSS25F 25W	PSS55D 55W
Input					
Voltage	110–240 Vac	380–480 Vac	110–240 Vac	380–480 Vac	480–600 Vac three-phase
Input current (rms)	0.19A	0.1A	0.45A	0.17A	0.07A/phase
Frequency	47–63 Hz	47–63 Hz	47–63 Hz	47–63 Hz	47–63 Hz
Voltage range	± 10%	± 10%	± 10%	± 10%	± 15%
Inrush current	25A	25A	35A	35A	15A
Overvoltage	330 Vac	550 Vac	330 Vac	550 Vac	Varistor
Internal input fuse	T2A at 250V	T2A at 250V	T4A at 250V	T2A at 250V	—
External fusing	Not required 2A 250 Vac slow blow	Not required 2A 250 Vac slow blow	Not required 2A 250 Vac slow blow	Not required 2A 250 Vac slow blow	3 x 1A 600 Vac slow blow
Output					
Voltage nominal	24 Vdc	24 Vdc	24 Vdc	24 Vdc	24 Vdc
Voltage regulation	± 10%	± 10%	± 10%	± 10%	± 3.5%
Current nominal	0.4A	0.4A	1.0A	1.0A	2.3A
Voltage adj. range	None	None	None	None	None
Current surge	1A	1A	6.8A	6.8A	10A
Current surge time	35 ms	35 ms	85 ms	85 ms	180 ms
Hold up time	100 ms	100 ms	100 ms	100 ms	30 ms
Max. load capacitance	10,000 µF	10,000 µF	10,000 µF	10,000 µF	10,000 µF
Switching frequency	60k Hz	60k Hz	100k Hz	100k Hz	61k Hz
Efficiency at max. load	80%	75%	80%	80%	85%
Output ripple	± 1%	± 1%	± 1%	± 1%	± 1%
Protection					
Short circuit	Auto restart	Auto restart	Auto restart	Auto restart	Auto restart
Overvoltage	No	No	No	No	No
Undervoltage	No	No	No	No	No
Overtemperature	None. Software in micro controller	None. Software in micro controller	None. Software in micro controller	None. Software in micro controller	None. Software in micro controller
Overcurrent	0.8A typical at 24V for >100 ms	0.8A typical at 24V for >160 ms	6.8A typical at 24V for >160 ms	6.8A typical at 24V for >160 ms	10A typical 24V for >300 ms
Galvanic Isolation					
Input to output	1.5 kV	2 kV	1.5 kV	2 kV	4 kV
Input/output to rail	1.5 kV	2 kV	1.5 kV	2 kV	4 kV
Input to ground	1.5 kV	2 kV	1.5 kV	2 kV	2.0 kV
Output to ground	200V	200V	200V	200V	250V
Special Features					
Cooling	Convection	Convection	Convection	Convection	Convection
Load sharing	None	None	None	None	None
Redundancy	None	None	None	None	None
Analog outputs	None	None	None	None	None
Fault relay	None	None	None	None	None

PSS Series, PSS10E–PSS55D, continued

Capacity	PSS10E 10W	PSS10F 10W	PSS25E 25W	PSS25F 25W	PSS55D 55W
Wire Size					
Input	20–14 AWG	20–14 AWG	20–14 AWG	20–14 AWG	20–14 AWG
Output	20–14 AWG	20–14 AWG	20–14 AWG	20–14 AWG	20–14 AWG
I/O	None	None	None	None	None
Indications					
Indicators	Green LED (DC on)	Green LED (DC on)	Green LED (DC on)	Green LED (DC on)	Green LED (DC on)
Physical Data					
Dimensions					
Length x Width x Depth in Inches (mm)	4.49 x 1.97 x 4.49 (114 x 50 x 114)	4.49 x 1.97 x 4.49 (114 x 50 x 114)	4.49 x 1.97 x 4.49 (114 x 50 x 114)	4.49 x 1.97 x 4.49 (114 x 50 x 114)	2.32 x 6.19 x 6.00 (59 x 157 x 154)
Weight (kg)	0.57 (0.26)	0.64 (0.29)	0.73 (0.33)	0.81 (0.37)	2.45 (1.1)
Mounting and recommended clearance	TS35 rail or chassis; leave 4 in. (10 cm) free space on venting sides.	TS35 rail or chassis; leave 4 in. (10 cm) free space on venting sides.	TS35 rail or chassis; leave 4 in. (10 cm) free space on venting sides.	TS35 rail or chassis; leave 4 in. (10 cm) free space on venting sides.	—
Environmental Performance					
Storage temperature	–25 to 80°C	–25 to 80°C	–25 to 80°C	–25 to 80°C	–40 to 85°C
Operating temperature	–5 to 50°C	–5 to 50°C	–5 to 50°C	–5 to 50°C	–25 to 50°C
Storage humidity	5 to 95%	5 to 95%	5 to 95%	5 to 95%	5 to 95%
Operating humidity	<95% RH noncondensing	<95% RH noncondensing	<95% RH noncondensing	<95% RH noncondensing	20 to 85% noncondensing
Approvals/Certifications					
	UL, IEC, CSA	UL, IEC, CSA	UL, IEC, CSA	UL, IEC, CSA	cCSAus

ELC Series



ELC Series

Product Description

Eaton’s ELC power supplies are the perfect products for those applications requiring a very compact and low-cost source for 24 Vdc power. While these products were developed to be a perfect match for our Eaton Logic Controllers, they can be used in a variety of applications.

The lightweight, DIN rail mounted enclosures, wide input voltage range and robust screw terminals make these power supplies easy to install and use. They are available in 1A and 2A models.

Features, Benefits and Functions

- Universal input voltage: 85–264 Vac
- Compact size, with common depth and height across models allows for common panel depths and family consistency
- ELC styling provides maximum aesthetic appeal when used with Eaton Logic Controllers
- Front-mounted pressure plate screw terminals for a robust connection
- Removable finger-safe protective cover for terminals
- Power ON indication LED
- Integrated mounting hardware for panel mounting or DIN rail mounting

Contents

Description

	<i>Page</i>
PSG Series	V7-T6-3
PSS Series	V7-T6-8
ELC Series	
Product Selection	V7-T6-13
Technical Data and Specifications	V7-T6-13
Dimensions	V7-T6-14
EZ Power Supply	V7-T6-15
Sensor Power Supply	V7-T6-18

Standards and Certifications

- UL/cUL listed—UL 508
- CE marked
- RoHS compliant
- Class I, Division II for groups A, B, C, D



Product Selection

ELC-PS01

ELC Series



Description	Catalog Number
24 watt, 1 amp power supply	ELC-PS01
48 watt, 2 amp power supply	ELC-PS02

Technical Data and Specifications

ELC Series

Capacity	ELC-PS01 24W	ELC-PS02 48W
Input		
Nominal voltage	100–240 Vac	100–240 Vac
Voltage range	85–264 Vac	85–264 Vac
Frequency	47–63 Hz	47–63 Hz
Output		
Nominal output voltage	24 Vdc ± 3%	24 Vdc ± 3%
Nominal current	1A	2A
Efficiency	78% to 87% typical at full load	78% to 87% typical at full load
Residual ripple/peak switching (20 MHz)	< 100 mV typical at full load	< 240 mV typical at full load
General/Physical Data		
Housing material	Plastic	Plastic
Dimensions (D)	60 mm	60 mm
Dimensions (W)	36.5 mm	55 mm
Dimensions (H)	90 mm	90 mm
Weight (g)	158	250
Operating temperature	0°C to +55°C	0°C to +55°C
Storage temperature	–25°C to +70°C	–25°C to +70°C
Operating humidity	50% to 95% RH, noncondensing	50% to 95% RH, noncondensing
Pollution degree	2	2
Approvals/Certifications		
	UL 508, CE, RoHS, EMC directive 89/336/EEC, low voltage directive 73/23/EEC	UL 508, CE, RoHS, EMC directive 89/336/EEC, low voltage directive 73/23/EEC
Safety and Protection		
Overload/short circuit protection	Auto recovery	Auto recovery

6.1

Power Supplies

General Purpose and Sensor Power Supplies

Dimensions

Approximate Dimensions in Inches (mm)

ELC-PS01 Power Supply

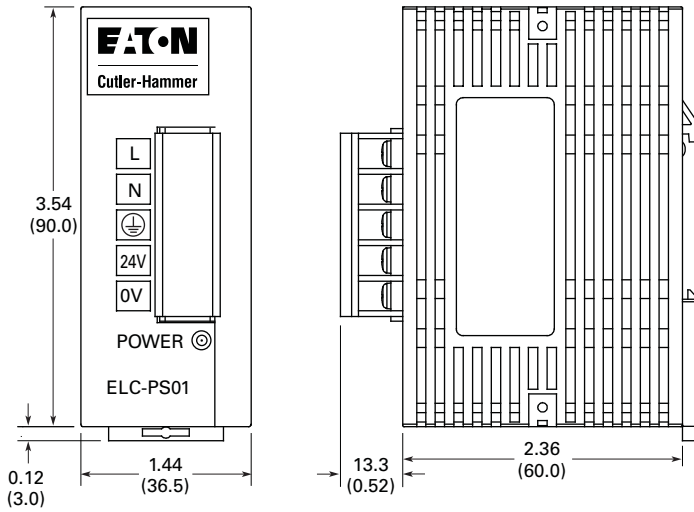

ELC-PS02 Power Supply

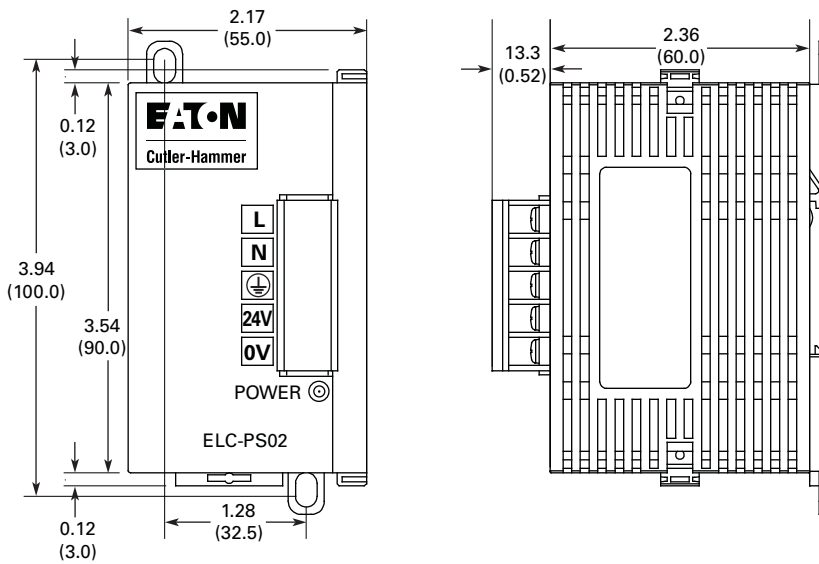

EZ Power Supply



Contents

Description	Page
PSG Series	V7-T6-3
PSS Series	V7-T6-8
ELC Series	V7-T6-12
EZ Power Supply	
Product Selection	V7-T6-16
Technical Data and Specifications	V7-T6-16
Dimensions	V7-T6-17
Sensor Power Supply	V7-T6-18

EZ Power Supply

Product Description

Eaton’s EZ power supplies are the perfect products for those applications requiring a low amperage 24 Vdc power source. While these products were developed to be a perfect match for our EZ relay products, they can be used in a variety of applications.

Features, Benefits and Functions

- Universal input voltage: 85–264 Vac
- Compact size, with common depth and height across models allows for common panel depths and family consistency
- EZ styling provides maximum aesthetic appeal when used with the Eaton EZ Relay products
- Wide operating temperature range (–25°C to 55°C)
- Power ON indication LED
- Optional mounting hardware for panel mounting (EZB4-101-GF1) or standard DIN rail mounting
- Finger-safe, side-entry screw clamp terminals for clean wiring

Standards and Certifications

- UL listed
- CSA certified
- CE marked
- RoHS compliant
- Class I, Division II rated for groups A, B, C, D



Product Selection

EZ200-POW

EZ Power Supply



Description	Catalog Number
100–240 Vac input to 12 Vdc at 20 mA/24 Vdc at 250 mA	EZ200-POW
100–240 Vac input to 24 Vdc at 1.25A	EZ400-POW

6

Technical Data and Specifications

EZ Series

Capacity	EZ200-POW 6W	EZ400-POW 30W
Input		
Nominal voltage	100–240 Vac	100–240 Vac
Voltage range	85–264 Vac	85–264 Vac
Frequency	47–63 Hz	47–63 Hz
Output		
Nominal output voltage	24 Vdc ± 3%	24 Vdc ± 3%
Nominal current	0.25A	1.25A
General/Physical Data		
Housing material	Plastic	Plastic
Dimensions (D)	56.5 mm	56.5 mm
Dimensions (W)	35.5 mm	71.5 mm
Dimensions (H)	90 mm	90 mm
Operating temperature	–25°C to +55°C	–25°C to +55°C
Storage temperature	–40°C to +70°C	–40°C to +70°C
Pollution degree	2	2
Connection cables		
Solid	0.2–4.0 mm ² (AWG 22-12)	0.2–4.0 mm ² (AWG 22-12)
Flexible	0.2–2.5 mm ² (AWG 221-12)	0.2–2.5 mm ² (AWG 221-12)
Approvals/Certifications		
	UL, CE, RoHS, CSA, EN 50178m IEC/EN 60947	UL, CE, RoHS, CSA, EN 50178m IEC/EN 60947
Safety and Protection		
Overload/short circuit protection	Yes	Yes
Overcurrent limitation form	0.3A	1.4A
Degree of protection	IP20	IP20
RFI suppression	EN 55011, EN 55022 Class B, IEC 61000-6-1, 2, 3, 4	EN 55011, EN 55022 Class B, IEC 61000-6-1, 2, 3, 4
Potential isolation (prim./sec.)	Yes, SELV, (to EN 600950, VDE 805)	Yes, SELV, (to EN 600950, VDE 805)

Dimensions

Approximate Dimensions in Inches (mm)

EZ200-POW/EZ256-HCI and EZ400-POW Series

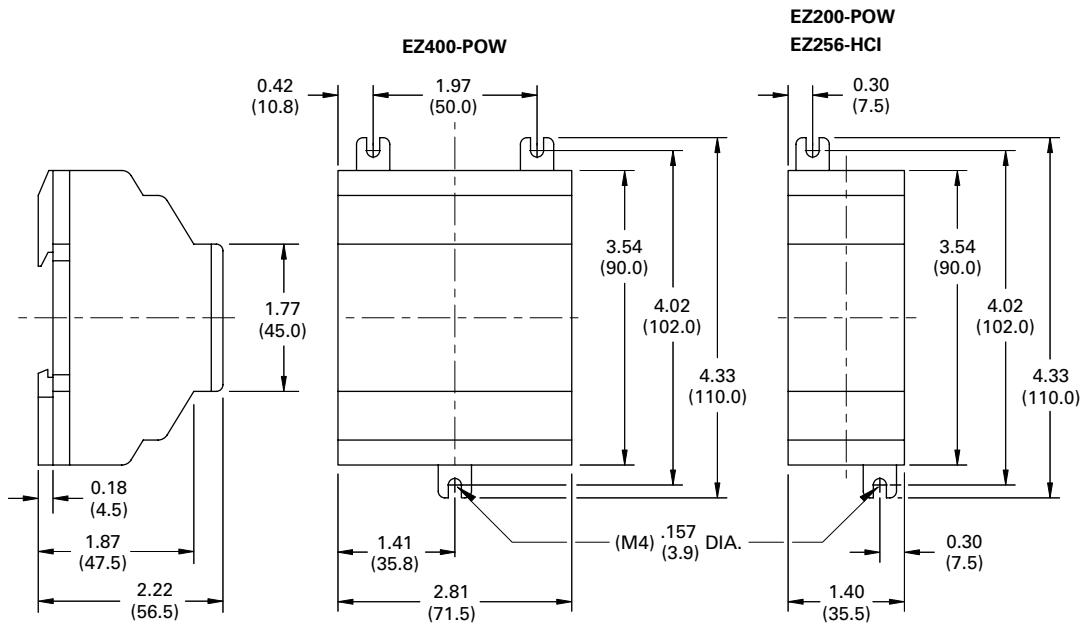

Sensor Power Supply



6

Sensor Power Supply

Product Description

Eaton’s sensor power supply was specially designed to be used with the 200 Series and E68 Series zero pressure accumulation systems, but is also suitable for use in a wide variety of applications. The unit delivers 100W output at 27 Vdc and supports easy, Class II wiring. The power supply is a tamper-proof, rugged component easily mounted to a conveyor side-channel or support. Internal components are fully encapsulated in a strong die-cast housing to stand up to rugged handling, ensuring flawless performance in any material handling environment.

Features, Benefits and Functions

- Integrated AC junction box for one-step mounting and wiring without the need for additional accessories
- Built-in DC power health contact allows easy monitoring of power supply status
- Unitized design features a tamper-proof encapsulated construction to reduce the risk of damage associated with conventional open control-panel type construction
- Built-in slug-release input converts an AC or DC input to the appropriate DC signal for integration with the 200 Series and E68 Series zero pressure accumulation systems
- Dual output connection terminals to make it easy and convenient to locate the power supply at the center of the cable run
- Power switch protected against accidental operation
- Power in and out indicators show status at a glance
- Conduit entry box for NEC compliance
- Simple mounting with two 1/4-inch bolts
- Rugged die-cast housing
- Fully encapsulated electronics

Standards and Certifications

- UL listed
- CSA approved



Contents

<i>Description</i>	<i>Page</i>
PSG Series	V7-T6-3
PSS Series	V7-T6-8
ELC Series	V7-T6-12
EZ Power Supply	V7-T6-15
Sensor Power Supply	
Product Selection	V7-T6-19
Technical Data and Specifications	V7-T6-19
Wiring Diagram	V7-T6-20
Dimensions	V7-T6-20

Product Selection

PS256A_

Sensor Power Supply



Output	Slug Input	Type	Slug Output	Catalog Number
Operating Voltage 105–132 Vac				
27 Vdc, 100W; short circuit, overload and overvoltage protection (cycle power to reset)	15–132 Vac/Vdc 3 mA minimum	Standard For use with 200 Series and E68 systems	Sinking or sourcing, switch selectable; 80 mA maximum; short circuit protection for loads less than 32 Vac or Vdc (auto reset)	PS256A-01B1 ②
	15–132 Vac/Vdc 3 mA minimum	High current slug For use with solenoid valve systems requiring full current slug signals	Sinking only; 100W output; short circuit, overload and overvoltage protection (cycle power to reset) ①	PS256A-04B1 ②

6

Technical Data and Specifications

Sensor Power Supply

Description	PS256A-01B1	PS256A-04B1
Input power	144W, maximum inrush 30A from cold start	144W, maximum inrush 30A from cold start
Input voltage	105–132 Vac	105–132 Vac
Input current (full load)	105 Vac–1.92A, 115 Vac–1.65A, 132 Vac–1.5A	105 Vac–1.92A, 115 Vac–1.65A, 132 Vac–1.5A
Output power	100W	100W
Output voltage	27 Vdc	27 Vdc
Output protection	Short circuit, overload and overvoltage protection (cycle power to reset), diode protected	Short circuit, overload and overvoltage protection (cycle power to reset), diode protected
Regulation	± 3%	± 3%
Slug input	15–132 Vac/Vdc	15–132 Vac/Vdc
Slug output	Sinking or sourcing, switch selectable; 80 mA maximum; short circuit protection for loads less than 32 Vac or Vdc (auto reset)	Sinking only; 100W output; short circuit, overload and overvoltage protection (cycle power to reset) ①
Indicators	Red LED: AC In; Green LED: DC Out	Red LED: AC In; Green LED: DC Out
DC fail indication output	NO contact, solid-state relay, 80 mA maximum	NO contact, solid-state relay, 80 mA maximum
Temperature range	–13° to 131°F (–25° to 55°C)	–13° to 131°F (–25° to 55°C)
Vibration	20g	20g
Enclosure material	Die-cast aluminum	Die-cast aluminum
Enclosure rating	NEMA 1	NEMA 1
Connections	Main output/slug output: Two three-position finger protected barrier strips; AC line input, DC fail indication and slug input: 8-position screw terminal strip inside conduit entry box	Main output/slug output: Two three-position finger protected barrier strips; AC line input, DC fail indication and slug input: 8-position screw terminal strip inside conduit entry box

Notes

- ① Total output power of supply is 100W. Total supply output power (100W) = main output power + slug output power.
 ② Stocked product, typical order quantities guaranteed in stock.

6.1

Power Supplies

General Purpose and Sensor Power Supplies

Wiring Diagram

Sensor Power Supply

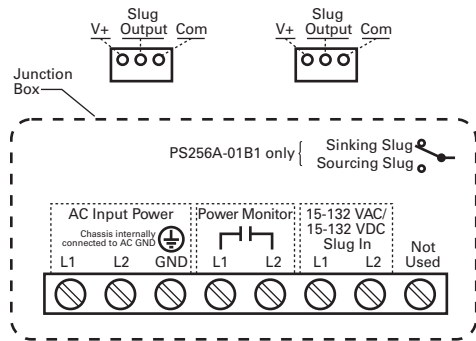

Dimensions

Approximate Dimensions in Inches (mm)

Sensor Power Supply

