

SLX9000 Adjustable Frequency Drives

Contents

<i>Description</i>	<i>Page</i>
SLX9000 Open Drives	
Product Description	2
Features	2
Technical Data and Specifications	3
Catalog Number Selection	4
Product Selection	5
Options	7
Accessories	8
Dimensions	9
Replacement Parts	11
SLX9000 Enclosed Drives	
Product Description	12
Features	12
Standards and Certifications	12
Technical Data and Specifications	13
Catalog Number Selection	14
Product Selection	17
Dimensions	19

Note: Supplement to Publication No. CA08102001E — Tab 40.



SLX9000 Open Drive

SLX9000 Open Drives

Product Description

Cutler-Hammer® SLX9000 Series Adjustable Frequency Drives from Eaton's electrical business are the next generation of drives specifically engineered for today's commercial and industrial applications. The power unit makes use of the most sophisticated semiconductor technology and a highly modular construction that can be flexibly adapted to the customer's needs.

The input and output configuration (I/O) is designed with modularity in mind. The I/O is comprised of option cards, each with its own input and output configuration.

The control module is designed to accept a total of two of these cards. The cards contain not only normal analog and digital inputs but also fieldbus cards.

These drives continue the tradition of robust performance, and raise the bar on features and functionality, ensuring the best solution at the right price.

The 9000X Family of Drives includes HVX9000, SVX9000, SLX9000 and SPX9000. 9000X Series drive ratings are rated for either high overload (I_H) or low overload (I_L). I_L indicates 110% overload capacity for 1 minute out of 10 minutes. I_H indicates 150% overload capacity for 1 minute out of 10 minutes.

Features

- Robust design — proven 500,000 hours MTBF
- Integrated 3% line reactors standard
- EMI/RFI Filters H standard
- Simplified operating menu allows for typical programming changes, while programming mode provides control of everything
- Keypad — LCD operation from keypad
- Standard NEMA Type 12 keypad on all drives
- The SLX9000 can be flexibly adapted to a variety of needs using our pre-installed "All-In-One Application" programs
- Additional I/O and communication cards provide plug and play functionality
- I/O connections with simple quick connection terminals
- The SLX9000 accommodates the standard I/O and an integrated RS-485 (Modbus) connection. There is room for two option cards with more I/O or other functionality
- UL Listed
- Hand-Held Auxiliary 24V Power Supply allows programming/monitoring of control module without applying full power to the drive
- Control logic can be powered from an external auxiliary control panel, internal drive functions and fieldbus if necessary
- Brake Chopper standard
- NEMA Type 1 and NEMA Type 12 enclosures available

June 2006

Open Drives

Technical Data and Specifications

Table 1. SLX9000 Specifications

Description	Specification
Input Ratings	
Input Voltage (V_{in})	+10% / -15%
Input Frequency (f_{in})	50/60 Hz (variation up to 45 – 66 Hz)
Connection to Power	Once per minute or less (typical operation)
High Withstand Rating	100 kAIC
Output Ratings	
Output Voltage	0 to V_{in}
Continuous Output Current	I_H rated 100% at 122°F (50°C) I_L rated 100% at 104°F (40°C)
Overload Current (I_H/I_L)	150% I_H , 110% I_L for 1 min.
Output Frequency	0 to 320 Hz
Frequency Resolution	.01 Hz
Initial Output Current (I_H)	250% for 2 seconds
Control Characteristics	
Control Method	Frequency Control (V/f) Open Loop: Sensorless Vector Control
Switching Frequency	Adjustable with Parameter 2.6.9 1 to 16 kHz; default 10 kHz
Frequency Reference	Analog Input: Resolution .1% (10-bit), accuracy \pm 1% V/Hz Panel Reference: Resolution .01 Hz
Field Weakening Point	30 to 320 Hz
Acceleration Time	0 to 3000 sec.
Deceleration Time	0 to 3000 sec.
Braking Torque	DC brake: 30% \times T_n (without brake option)
Ambient Conditions	
Ambient Operating Temperature	14°F (-10°C), no frost to 122°F (+50°C) I_H 14°F (-10°C), no frost to 104°F (+40°C) I_L
Storage Temperature	-40°F (-40°C) to 158°F (70°C)
Relative Humidity	0 to 95% RH, noncondensing, non-corrosive, no dripping water
Air Quality	Chemical vapors: IEC 721-3-3, unit in operation, class 3C2; Mechanical particles: IEC 721-3-3, unit in operation, class 3S2
Altitude	100% load capacity (no derating) up to 3280 ft. (1000m); 1% derating for each 328 ft. (100m) above 3280 ft. (1000m); max. 9842 ft. (3000m)
Vibration	EN 50178, EN 60068-2-6; 5 to 50 Hz, Displacement amplitude 1 mm (peak) at 3 to 15.8 Hz, Max. acceleration amplitude 1G at 15.8 to 150 Hz
Shock	EN 50178, EN 60068-2-27 UPS Drop test (for applicable UPS weights) Storage and ship- ping: max. 15G, 11 ms (in package)
Enclosure Class	NEMA 1/IP21 or NEMA 12/IP54

Description	Specification
Standards	
Product	IEC 61800-2
Safety	UL 508C
EMC (at default settings)	Immunity: Fulfills all EMC immunity require- ments; Emissions: EN 61800-3, LEVEL H

Control Connections	
Analog Input Voltage	0 to 10V, R = 200 k Ω (-10 to 10V joystick con- trol) Resolution .1%; accuracy \pm 1%
Analog Input Current	0(4) to 20 mA; R_i - 250 Ω differential
Digital Inputs	Positive or negative logic; 18 to 30V DC
Auxiliary Voltage	+24V \pm 15%, max. 250 mA
Output Reference Volt- age	+10V +3%, max. load 10 mA
Analog Output	0(4) to 20 mA; R_L max. 500 Ω ; Resolution 10 bit; Accuracy \pm 2%
Relay Outputs	1 programmable Form C relay output Switching capacity: 24V DC / 8A, 250V AC / 8A, 125V DC / 0.4A

Protections	
Overcurrent Protection	Trip limit 4.0 \times I_H instantaneously
Overvoltage Protection	Yes
Undervoltage Protection	Yes
Earth Fault Protection	In case of earth fault in motor or motor cable, only the frequency converter is protected
Input Phase Supervision	Trips if any of the input phases are missing
Motor Phase Supervision	Trips if any of the output phases are missing
Overtemperature Protection	Yes
Motor Overload Protection	Yes
Motor Stall Protection	Yes
Motor Underload Protection	Yes
Short Circuit Protection	Yes (+24V and +10V Reference Voltages)

Table 2. Standard I/O Specifications

Description	Specification
3– Digital Input Programmable	24V: "0" \leq 10V, "1" \geq 18V; R_i > 5 k Ω
2 – Analog Input Configurable w/Jumpers	Voltage: 0 – \pm 10V, R_i > 200 k Ω Current: 0 (4) – 20 mA, R_i = 250 k Ω
1 – Digital Output Programmable	Form C Relays 250V AC 2 Amp or 30V DC 2 Amp resistive, 8 Amp switching
1 – Analog Output Programmable Configurable w/Jumper	0 – 20 mA, R_L < 500 ohms, resolution 10 Bits/0.1%
1 – RS-485 Serial	RS-485 Modbus Communication

Open Drives

Catalog Number Selection

Table 3. SLX9000 Adjustable Frequency Drive Catalog Numbering System

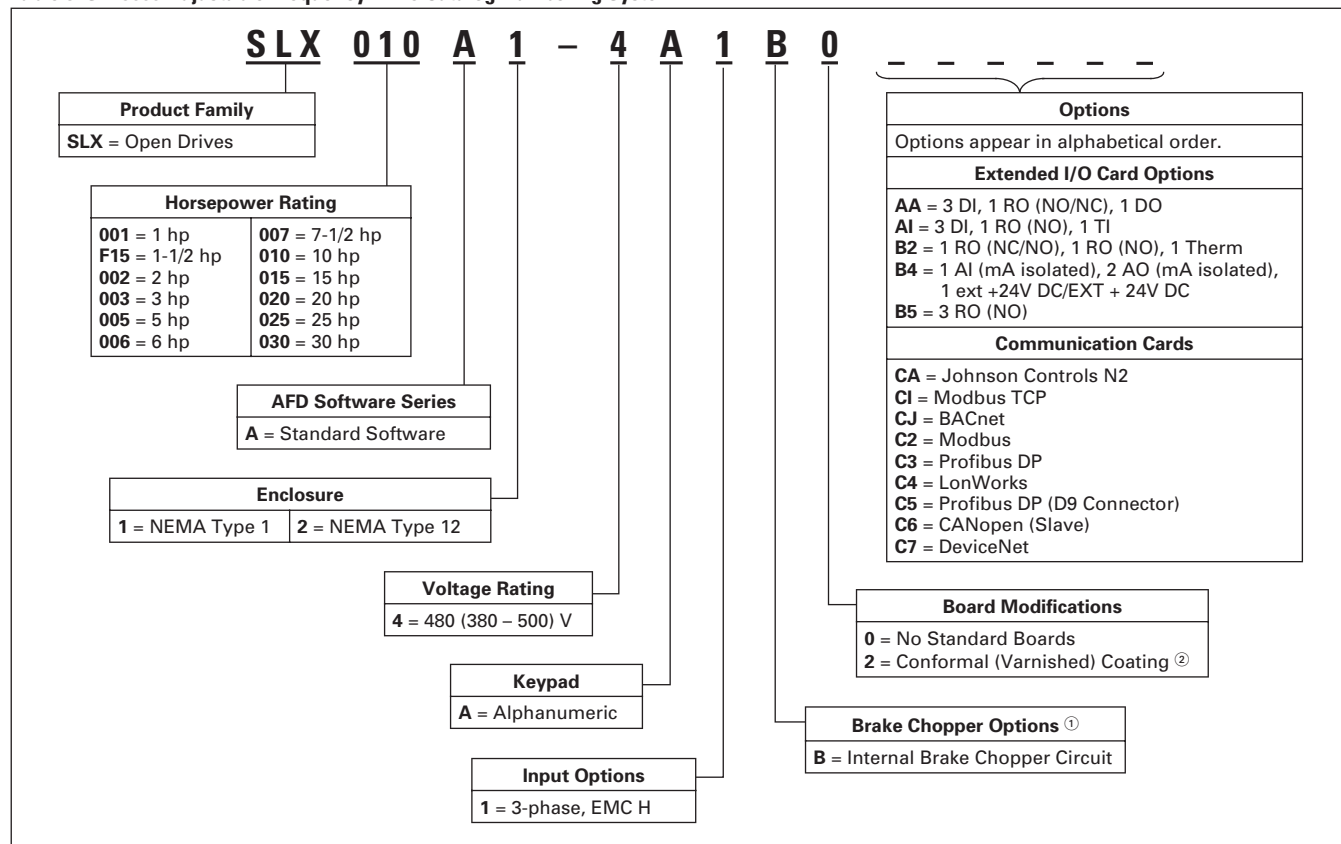
① 480V Drives up to 30 hp (I_H) are only available with Brake Chopper Option B.

② Factory promise delivery. Consult Sales Office for availability.

June 2006

Open Drives

Product Selection

480V SLX9000 Drives

Table 4. 380 – 500V, NEMA Type 1 Drive

Frame Size	Delivery Code	hp (I _H)	Current (I _H)	hp (I _L)	Current (I _L)	Catalog Number	Price U.S. \$
MF4	W	1	2.2	1-1/2	3.3	SLX001A1-4A1B0	1,300.
		1-1/2	3.3	2	4.3	SLXF15A1-4A1B0	1,345.
		2	4.3	3	5.6	SLX002A1-4A1B0	1,420.
		3	5.6	5	7.6	SLX003A1-4A1B0	1,520.
		5	7.6	—	9	SLX005A1-4A1B0	1,850.
		—	9	7-1/2	12	SLX006A1-4A1B0	2,005.
		MF5	W	7-1/2	12	10	16
		10	16	15	23	SLX010A1-4A1B0	2,315.
		15	23	20	31	SLX015A1-4A1B0	2,690.
MF6	W	20	31	25	38	SLX020A1-4A1B0	3,665.
		25	38	30	46	SLX025A1-4A1B0	4,080.
		30	46	40	61	SLX030A1-4A1B0	4,990.

Table 5. 380 – 500V, NEMA Type 12 Drive

Frame Size	Delivery Code	hp (I _H)	Current (I _H)	hp (I _L)	Current (I _L)	Catalog Number	Price U.S. \$
MF4	F1	1	2.2	1-1/2	3.3	SLX001A2-4A1B0	1,475.
		1-1/2	3.3	2	4.3	SLXF15A2-4A1B0	1,530.
		2	4.3	3	5.6	SLX002A2-4A1B0	1,615.
		3	5.6	5	7.6	SLX003A2-4A1B0	1,725.
		5	7.6	—	9	SLX005A2-4A1B0	2,100.
		—	9	7-1/2	12	SLX006A2-4A1B0	2,280.
		MF5	F1	7-1/2	12	10	16
		10	16	15	23	SLX010A2-4A1B0	2,625.
		15	23	20	31	SLX015A2-4A1B0	3,055.
MF6	F1	20	31	25	38	SLX020A2-4A1B0	4,170.
		25	38	30	46	SLX025A2-4A1B0	4,640.
		30	46	40	61	SLX030A2-4A1B0	5,660.

Discount SymbolSS-2

Open Drives

SLX9000 Series Option Board Kits

The SLX9000 Series drives can accommodate a wide selection of expander and adapter option boards to customize the drive for your application needs. The drive's control unit is designed to accept a total of two option boards (see Figure 1).

The SLX9000 Drive accommodates the standard I/O and an integrated RS-485 (Modbus) connector.

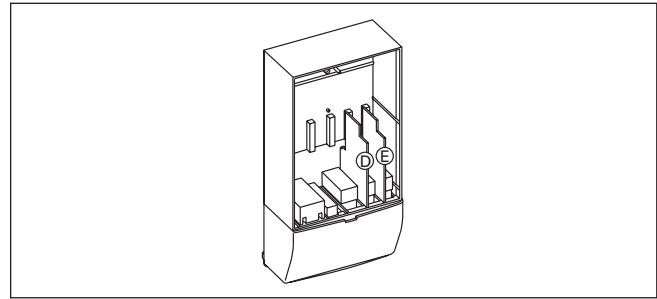

Figure 1. SLX9000 Series Option Boards

Table 6. Option Board Kits

Option Kit Description ②	Allowed Slot Locations ①	Field Installed		Factory Installed		SLX9000 Programs
		Catalog Number	Price U.S. \$	Option Designator	Adder U.S. \$	
Extended I/O Card Options						
3 DI, 1 RO (NO/NC), 1 DO	D	OPTAA	150.	AA	255.	X
3 DI, 1 RO (NO), 1 TI	D	OPTAI	150.	AI	255.	X
1 RO (NC/NO), 1 RO (NO), 1 Therm	D, E	OPTB2	221.	B2	326.	X
1 AI (mA isolated), 2 AO (mA isolated), 1 ext +24V DC/EXT +24V DC	D, E	OPTB4	336.	B4	441.	X
3 RO (NO)	D, E	OPTB5	200.	B5	305.	X
Communication Cards						
Johnson Controls N2	D, E	OPTC2	237.	CA	342.	X
Modbus TCP	D, E	OPTCI	590.	CI	695.	X
BACnet	D, E	OPTCJ	280.	CJ	385.	X
Modbus	D, E	OPTC2	237.	C2	342.	X
Profibus DP	D, E	OPTC3	431.	C3	540.	X
LonWorks	D, E	OPTC4	580.	C4	685.	X
Profibus DP (D9 Connector)	D, E	OPTC5	580.	C5	685.	X
CanOpen (Slave)	D, E	OPTC6	580.	C6	685.	X
DeviceNet	D, E	OPTC7	580.	C7	685.	X
Keypad						
SLX9000 Series LCD Keypad (Replacement Keypad)		Keypad-LCD	150.	—	—	X
SLX9000 Series Remote Mount Keypad Unit (Keypad not included, includes 6.5 ft. cable, keypad holder, mounting hardware)		OPTDRA-02L	200.	—	—	X

① Option card must be installed in one of the slots listed for that card. Slot indicated in **Bold** is the preferred location.

② AI = Analog Input; AO = Analog Output, DI = Digital Input, DO = Digital Output, RO = Relay Output

Johnson Controls Metasys™ N2 Network Communications

The OPTC2 fieldbus board provides communication between the 9000X Drive and a Johnson Controls Metasys™ N2 network. With this connection, the drive can be controlled, monitored and programmed from the Metasys system. The N2 fieldbus is available as a factory installed option and as a field installable kit.

Modbus/TCP Network Communications

The Modbus/TCP Network Card OPTCI is used for connecting the 9000X Drive to Ethernet networks utilizing Modbus protocol. It includes an RJ-45 pluggable connector. This interface provides a selection of standard and custom register values to communicate drive parameters. The board supports 10 Mbps and 100 Mbps communication speeds. The IP address of the board is configurable over Ethernet using a supplied software tool.

BACnet Network Communications

The BACnet Network Card OPTCJ is used for connecting the 9000X Drive to BACnet networks. It includes a 5.08 mm pluggable connector. Data transfer is Master-Slave/Token

Passing (MS/TP) RS-485. This interface uses a collection of 30 Binary Value Objects (BVOs) and 35 Analog Value Objects (AVOs) to communicate drive parameters. The card supports 9.6, 19.2 and 38.4 Kbaud communication speeds and supports network addresses 1 – 127.

Modbus RTU Network Communications

The Modbus Network Card OPTC2 is used for connecting the 9000X Drive as a slave on a Modbus network. The interface is connected by a 9-pin DSUB connector (female) and the baud rate ranges from 300 to 19200 baud. Other communication parameters include an address range from 1 to 247; a parity of None, Odd or Even; and the stop bit is 1.

Profibus Network Communications

The Profibus Network Card OPTC3 is used for connecting the 9000X Drive as a slave on a Profibus-DP network. The interface is connected by a 9-pin DSUB connector (female). The baud rates range from 9.6K baud to 12M baud, and the addresses range from 1 to 127.

Discount Symbol..... **SS-3**

June 2006

Open Drives

LonWorks Network Communications

The LonWorks Network Card OPTC4 is used for connecting the 9000X Drive on a LonWorks network. This interface uses Standard Network Variable Types (SNVT) as data types. The channel connection is achieved using a FTT-10A Free Topology transceiver via a single twisted transfer cable. The communication speed with LonWorks is 78 kBits/s.

CanOpen (Slave) Communications

The CanOpen (Slave) Network Card OPTC6 is used for connecting the 9000X Drive to a host system. According to ISO11898 standard cables to be chosen for CAN bus should have a nominal impedance of 120Ω, and specific line delay of nominal 5 nS/m. 120Ω line termination resistors required for installation.

DeviceNet Network Communications

The DeviceNet Network Card OPTC7 is used for connecting the 9000X Drive on a DeviceNet Network. It includes a 5.08 mm pluggable connector. Transfer method is via CAN using a 2-wire twisted shielded cable with 2-wire bus power cable and drain. The baud rates used for communication include 125K baud, 250K baud and 500K baud.

Options

Control Panel Options

Table 7. Control Panel Factory Options

Description	Factory Installed		Field Installed	
	Option Code	Adder U.S. \$	NEMA Type 1	
			Catalog Number	Price U.S. \$
SLX9000 Series LCD Keypad — This option is standard on all drives and consists of an RS-232 connection, backlit alphanumeric LCD display with nine indicators for the RUN status and two indicators for the control source. The seven pushbuttons on the panel are used for panel programming and monitoring of all SLX9000 parameters. The panel is detachable and isolated from the input line potential.	A	Standard	KEYPAD-LCD	150.
Keypad Remote Mounting Kit — This option is used to remote mount the SLX9000 keypad. Includes 6.5 ft. cable, keypad holder and mounting hardware.	—	—	OPTDRA-02L	200.

Table 8. Miscellaneous Options

Description	Catalog Number	Price U.S. \$
External Dynamic Braking Resistors — Used with the Dynamic Braking Chopper Circuit to absorb motor regenerative energy for stopping the load and to dissipate the energy flowing back into the drive. Resistors are separated into Standard Duty and Heavy-Duty. Standard Duty is defined as 20% duty or less with 100% braking torque, while Heavy-Duty is defined as 50% duty or less with 150% braking torque. <i>Consult factory.</i>	①	—

① Consult factory.

Brake Chopper Options

The Brake Chopper Circuit option is used for applications that require dynamic braking. Dynamic Braking resistors are not included with drive purchase. Consult the factory for dynamic braking resistors which are supplied separately. Resistors are not UL Listed.

Table 9. Conformal (Varnished) Coating Adder — 380 – 500V,
(See Catalog Number Description to order.)

Frame	Delivery Code	Adder U.S. \$
MF4	FP	263.
MF5	FP	263.
MF6	FP	263.

Table 10. Conformal Coated Board Kits ②

Field Installed		Factory Installed	
Catalog Number	Price U.S. \$	Option Designator	Adder U.S. \$
OPT_V ④	74.	③	74.

② See Option Catalog Numbers on Page 6.

③ Construct Catalog Numbers for factory installed per Table 3 on Page 4.

④ Replace “_” with the correct Catalog Number from Page 6. Example: OPTC2V.

Discount Symbol..... SS-2

Open Drives

Accessories

NEMA Type 12 Conversion Kit

The NEMA Type 12 kit option is used to convert a NEMA Type 1 to a NEMA Type 12 drive. The NEMA Type 12 Kit consists of a metal drive shroud, fan kit for some frames, adapter plate and plugs.

Table 11. NEMA Type 12 Conversion Kit

Frame Size	Delivery Code	Approximate Dimensions in Inches (mm)			Approximate Weight in Lb. (kg)	Catalog Number	Price U.S. \$
		Length	Width	Height	Weight		
MF4	W	13 (330)	7 (178)	4 (102)	4 (1.8)	OPTN12FR4	216.
MF5	W	16 (406)	8 (203)	7 (178)	5 (2.3)	OPTN12FR5	347.
MF6	W	21 (533)	10 (254)	5 (127)	7 (3.2)	OPTN12FR6	580.

Flange Kits

Flange Kit Type 12

The flange kit is utilized when the power section is mounted through the back panel of an enclosure. Includes flange mount brackets and NEMA Type 12 fan components. Metal shroud not included.

Table 12. Flange Kit Type 12 — MF4 – MF6 ①

Frame Size	Delivery Code	Catalog Number	Price U.S. \$
MF4	W	OPTTHRFR4	273.
MF5	W	OPTTHRFR5	294.
MF6	W	OPTTHRFR6	310.

① For installation of an SLX9000 NEMA Type 1 drive into a NEMA Type 12 oversized enclosure.

Flange Kit Type 1

Flange kits for NEMA 1 enclosure drive rating are determined by rating of drive.

Table 13. Flange Kit Type 1 — MF4 – MF6 ②

Frame Size	Delivery Code	Catalog Number	Price U.S. \$
MF4	FP	OPTTHR4	158.
MF5	FP	OPTTHR5	168.
MF6	FP	OPTTHR6	184.

② For installation of an SLX9000 NEMA Type 1 drive into a NEMA Type 1 oversized enclosure.

Flange Kit Type 12

Flange kits for NEMA 12 enclosure drive rating are determined by rating of drive.

Table 14. Flange Kit Type 12 — MF4 – MF6 ③

Frame Size	Delivery Code	Catalog Number	Price U.S. \$
MF4	FP	OPTTHR4	158.
MF5	FP	OPTTHR5	168.
MF6	FP	OPTTHR6	184.

③ For installation of an SLX9000 NEMA Type 12 drive into a NEMA Type 12 oversized enclosure.

June 2006

Open Drives

Dimensions

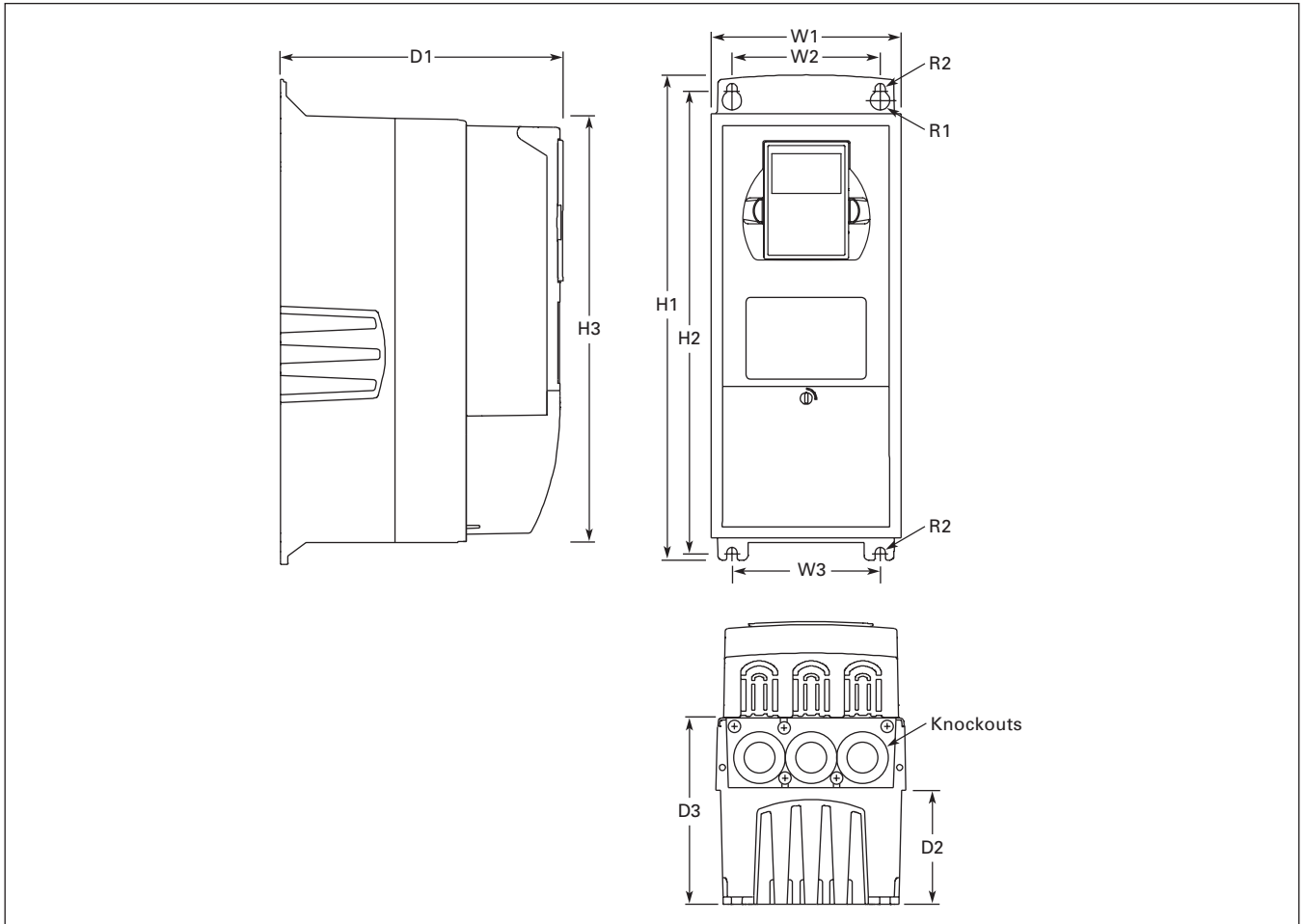

Figure 2. NEMA Type 1 and NEMA Type 12 SLX9000 Drive Dimensions, MF4 – MF6

Table 15. SLX9000 Drive Dimensions

Frame Size	Voltage	hp (I _H)	Approximate Dimensions in Inches (mm)											Weight Lbs. (kg)	Knockouts @ Inches (mm) N1 (O.D.)
			H1	H2	H3	D1	D2	D3	W1	W2	W3	R1 dia.	R2 dia.		
MF4	480V	1 – 5	12.9 (327)	12.3 (313)	11.5 (292)	7.5 (190)	3.0 (77)	5.0 (126)	5.0 (128)	3.9 (100)	—	.5 (13)	.3 (7)	11.0 (5)	3 @ 1.1 (28)
MF5	480V	7-1/2 – 15	16.5 (419)	16.0 (406)	15.3 (389)	8.4 (214)	3.9 (100)	5.8 (148)	5.6 (143)	3.9 (100)	—	.5 (13)	.3 (7)	17.9 (8)	2 @ 1.5 (37) 1 @ 1.1 (28)
MF6	480V	20 – 30	22.0 (558)	21.3 (541)	20.4 (519)	9.3 (237)	4.2 (105)	6.5 (165)	7.6 (195)	5.8 (148)	—	.6 (15.5)	.4 (9)	40.8 (19)	3 @ 1.5 (37)

Open Drives

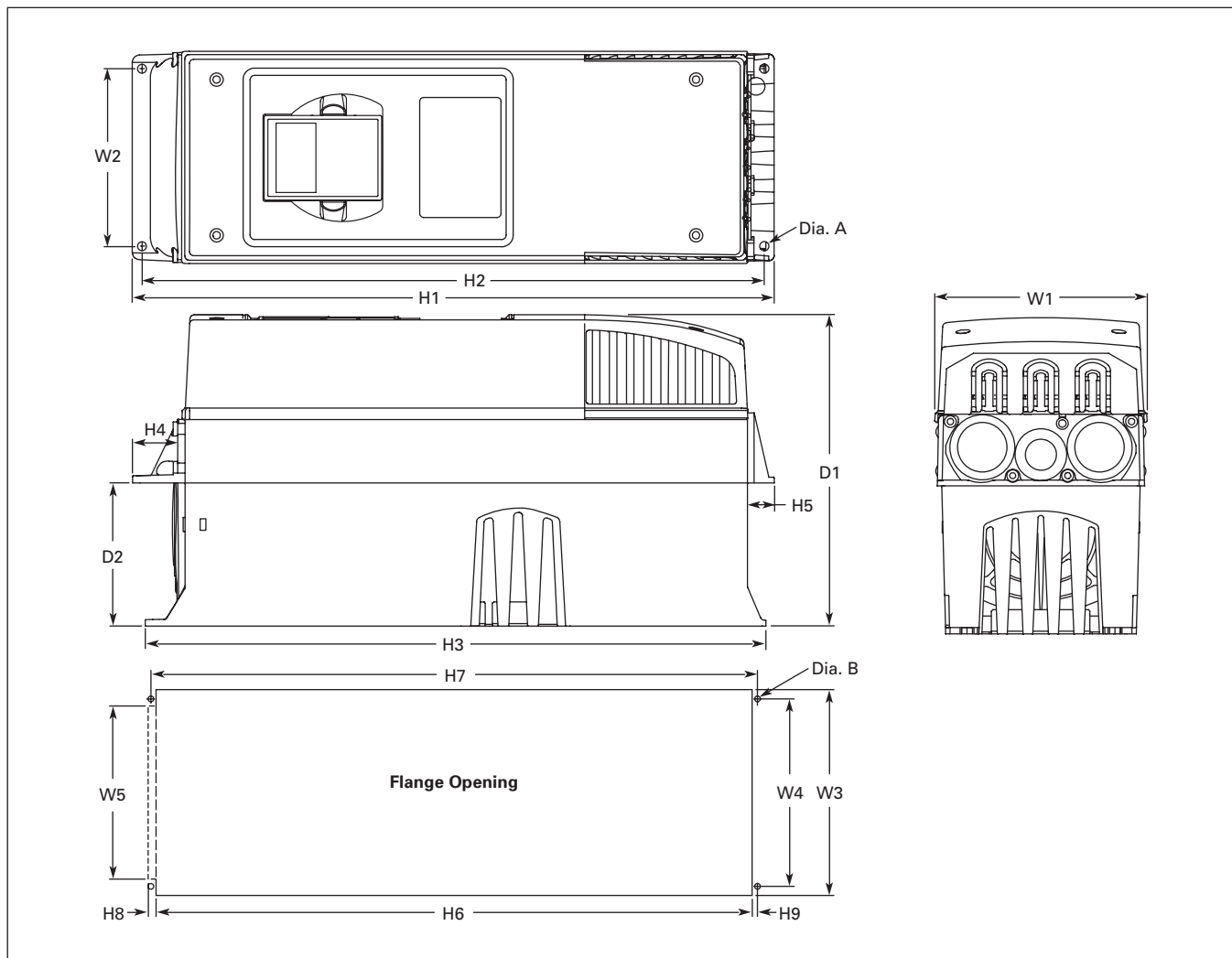

Figure 3. SLX9000 Dimensions, NEMA Type 1 and NEMA Type 12 with Flange Kit, MF4 – MF6

Table 16. Dimensions for SLX9000, MF4 – MF6 with Flange Kit

Frame Size	Approximate Dimensions in Inches (mm)									
	W1	W2	H1	H2	H3	H4	H5	D1	D2	Dia. A
MF4	5.0 (128)	4.5 (113)	13.3 (337)	12.8 (325)	12.9 (327)	1.2 (30)	.9 (22)	7.5 (190)	3.0 (77)	.3 (7)
MF5	5.6 (143)	4.7 (120)	17.0 (434)	16.5 (420)	16.5 (419)	1.4 (36)	.7 (18)	8.4 (214)	3.9 (100)	.3 (7)
MF6	7.7 (195)	6.7 (170)	22.0 (560)	21.6 (549)	22.0 (558)	1.2 (30)	.8 (20)	9.3 (237)	4.2 (106)	.3 (7)

Table 17. Dimensions for the Flange Opening, MF4 – MF6

Frame Size	Approximate Dimensions in Inches (mm)							
	W3	W4	W5	H6	H7	H8	H9	Dia. B
MF4	4.8 (123)	4.5 (113)	—	12.4 (315)	12.8 (325)	—	.2 (5)	.3 (7)
MF5	5.3 (135)	4.7 (120)	—	16.2 (410)	16.5 (420)	—	.2 (5)	.3 (7)
MF6	7.3 (185)	6.7 (170)	6.2 (157)	21.2 (539)	21.6 (549)	.3 (7)	.2 (5)	.3 (7)

Spare Units & Replacement Parts

Table 18. SLX9000 Spare Units & Replacement Parts

Frame hp (I _H)	MF4						MF5			MF6			Delivery Code	Catalog Number	Price U.S. \$
	1	1-1/2	2	3	5	7-1/2 ①	7-1/2	10	15	20	25	30			
Control Board															
1	1		1	1	1	1	1	1	1	1	1	1	W	VB00351	780.00
Power Boards															
1													FB	VB00350-0003-5	980.00
	1												FB	VB00350-0004-5	980.00
		1											FB	VB00350-0005-5	980.00
			1										FB	VB00350-0007-5	980.00
				1									FB	VB00350-0009-5	980.00
					1								FB	VB00350-0012-5	980.00
						1							FB	VB00357-0016-5	1,395.00
							1						FB	VB00357-0023-5	1,395.00
								1					FB	VB00357-0031-5	1,395.00
									1				FB	VB00358-0038-5	1,730.00
										1			FB	VB00358-0046-5	1,730.00
											1		FB	VB00358-0061-5	1,730.00
Electrolytic Capacitors															
2	2	2	2										W	PP01000	63.00
				2	2								W	PP01001	79.00
						2	2						W	PP01002	126.00
								2					W	PP01003	153.00
									2	2	2		W	PP01004	189.00
Cooling Fans															
1	1	1	1	1	1								W	PP01060	94.50
						1	1	1					W	PP01061	158.00
									1	1	1		W	PP01062	595.00
1	1	1	1	1	1								W	PP01086	105.00
						1	1	1					W	PP01088	179.00
									1	1	1		W	PP01049	105.00
IGBT Modules															
						1							W	CP01306	473.00
							1						W	CP01307	540.00
								1					W	CP01308	720.00
									1	1			W	CP01367	368.00
											1		W	CP01368	431.00
									1	1			W	PP01022	1,070.00
												1	W	PP01023	1,210.00
1	1	1											FP	PP01032	295.00
			1	1	1								FP	PP01033	315.00
Capacitors															
1	1	1	1	1	1								FP	PP04051	32.00
1	1	1	1	1	1								FP	PP04052	35.00
						1	1	1					FP	PP05051	45.00
						2	2	2					FP	PP00035	32.00
									1	1	1		FP	PP06051	55.00
									1	1	1		FP	PP06052	115.00

① I_L only; has no corresponding I_H rated hp rating.

Enclosed Drives

SLX9000 Enclosed Drives

Product Description

- **Standard Enclosed** — covers a wide range of the most commonly ordered options. Pre-engineering eliminates the lead time normally associated with customer specific options.
- **Modified Standard Enclosed** — applies to specific customer requirements that vary from the Standard Enclosed offering, such as the need for an additional indicating light or minor modifications to drawings. *Consult your Eaton representative for assistance in pricing and lead time.*
- **Custom Engineered** — for those applications with more unique or complex requirements, these are individually engineered to the customer's needs. *Consult your Eaton representative for assistance in pricing and lead time.*

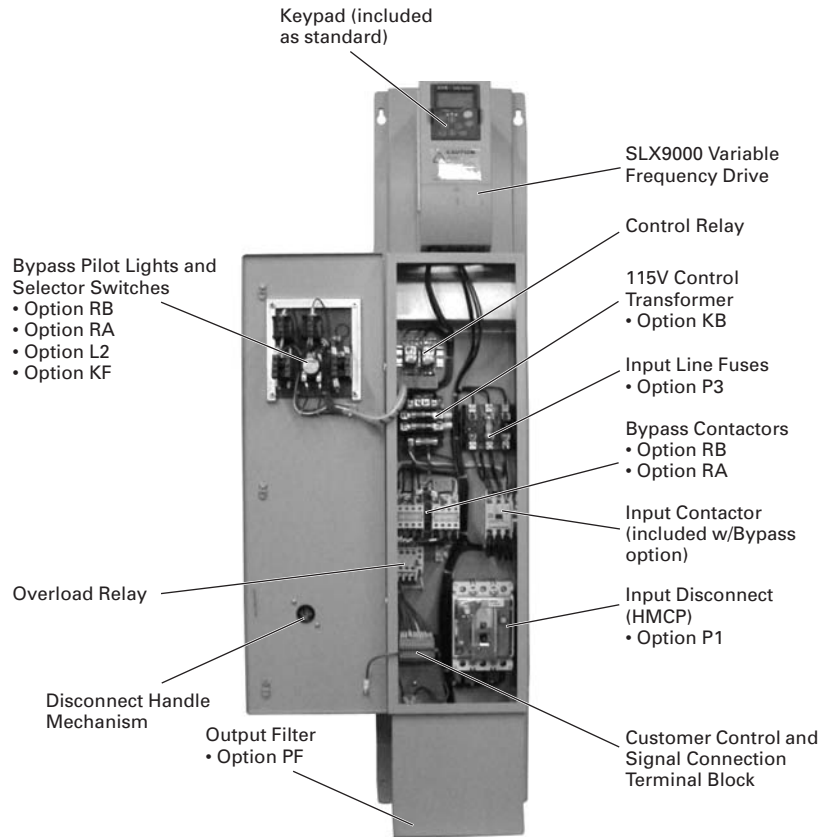

Enclosed 9000X Series Drive

Features

- NEMA Type 1, Type 12 or Type 3R enclosures
- Input Voltage: 480V
- Complete range of control, network and power options
- Horsepower range:
 - 480V — 1 to 30 hp I_H ;
 - 1-1/2 to 40 hp I_L
- HMCP padlockable

Standards and Certifications

- UL Listed
- cUL Listed

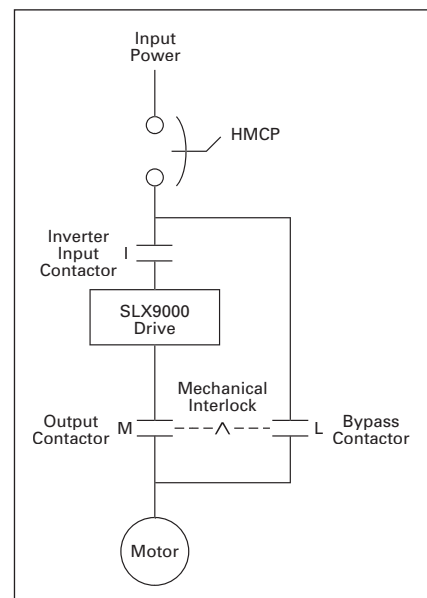

Figure 4. Power Diagram for Bypass Options RB and RA

June 2006

Enclosed Drives

Technical Data and Specifications

Table 19. Specifications

Feature Description	SLX9000 Enclosed Products — NEMA Type 1, NEMA Type 12 or NEMA Type 3R
Primary Design Features	
45 – 66 Hz Input Frequency	Standard
Output: AC Volts Maximum	Input Voltage Base
Output Frequency Range: Hz	0 – 320
Initial Output Current (I _H)	250% for 2 seconds
Overload: 1 Minute (I _H /I _L)	150%/110%
Enclosure Space Heater	Optional
Oversize Enclosure	Standard
Output Contactor	Optional
Bypass Motor Starter	Optional
Listings	UL, cUL
Protection Features	
Incoming Line Fuses	Optional
AC Input Circuit Disconnect	Optional
Line Reactors	Standard
Phase Rotation Insensitive	Standard
EMI Filter	Standard
Input Phase Loss Protection	Standard
Input Overvoltage Protection	Standard
Line Surge Protection	Standard
Output Short Circuit Protection	Standard
Output Ground Fault Protection	Standard
Output Phase Protection	Standard
Overtemperature Protection	Standard
DC Overvoltage Protection	Standard
Drive Overload Protection	Standard
Motor Overload Protection	Standard
Programmer Software	Optional
Local/Remote Keypad	Standard
Keypad Lockout	Standard
Fault Alarm Output	Standard
Built-In Diagnostics	Standard
Input/Output Interface Features	
Setup Adjustment Provisions: Remote Keypad/Display Personal Computer	Standard Standard
Operator Control Provisions: Drive Mounted Keypad/Display Remote Keypad/Display Conventional Control Elements Serial Communications 115V AC Control Circuit	Standard Standard Standard Optional Optional
Speed Setting Inputs: Keypad 0 – 10V DC Potentiometer/Voltage Signal 4 – 20 mA Isolated 4 – 20 mA Differential 3 – 15 psig	Standard Standard Configurable Configurable Optional
Analog Outputs: Speed/Frequency Torque/Load/Current Motor Voltage Kilowatts 0 – 10V DC Signals 4 – 20 mA DC Signals Isolated Signals	Standard Programmable Programmable Programmable Configurable w/Jumpers Standard Optional

Feature Description	SLX9000 Enclosed Products — NEMA Type 1, NEMA Type 12 or NEMA Type 3R
Input/Output Interface Features (Continued)	
Discrete Outputs: Fault Alarm Drive Running Drive at Set Speed Optional Parameters Dry Contacts Additional Discrete Outputs	Standard Standard Programmable 14 1 (Relay Form C) Optional
Communications: RS-232 RS-422/485 DeviceNet™ Modbus RTU CanOpen (Slave) Profibus-DP Lonworks® Johnson Controls Metasys™ N2	Standard Optional Optional Optional Optional Optional Optional Optional

Performance Features

Sensorless Vector Control	Standard
Volts/Hertz Control	Standard
IR and Slip Compensation	Standard
Electronic Reversing	Standard
Dynamic Braking	Standard
DC Braking	Standard
PID Setpoint Controller	Programmable
Critical Speed Lockout	Standard
Current (Torque) Limit	Standard
Adjustable Acceleration/Deceleration	Standard
Linear or S Curve Accel/Decel	Standard
Jog at Preset Speed	Standard
Thread/Preset Speeds	7
Automatic Restart	Selectable
Coasting Motor Start	Standard
Coast or Ramp Stop Selection	Standard
Elapsed Time Meter	Optional
Carrier Frequency Adjustment	1 – 16 kHz

Standard Conditions for Application and Service

Operating Ambient Temperature	0 – 40°C
Storage Temperature	-40 – 60°C
Humidity (Maximum), Non-condensing	95%
Altitude (Maximum without Derate)	3300 ft. (1000m)
Line Voltage Variation	+10/-15%
Line Frequency Variation	45 – 66 Hz
Efficiency	>96%
Power Factor (Displacement)	>96

Table 20. Standard I/O Specifications

Description	Specification
3– Digital Input Programmable	24V: "0" ≤ 10V, "1" ≥ 18V, R _i > 5 kΩ
2 – Analog Input Configurable w/Jumpers	Voltage: 0 – ±10V, R _i > 200 kΩ Current: 0 (4) – 20 mA, R _i = 250 kΩ
1 – Digital Output Programmable	Form C Relays 250V AC 2 Amp or 30V DC 2 Amp resistive, 8 Amp switching
1 – Analog Output Programmable Configurable w/Jumper	0 – 20 mA, R _L < 500 ohms, resolution 10 Bits/0.1%
1 – RS-485 Serial	RS-485 Modbus Communication

Enclosed Drives

Catalog Number Selection

Table 21. SLX9000 Enclosed NEMA Type 1/12/3R Drive Catalog Numbering System

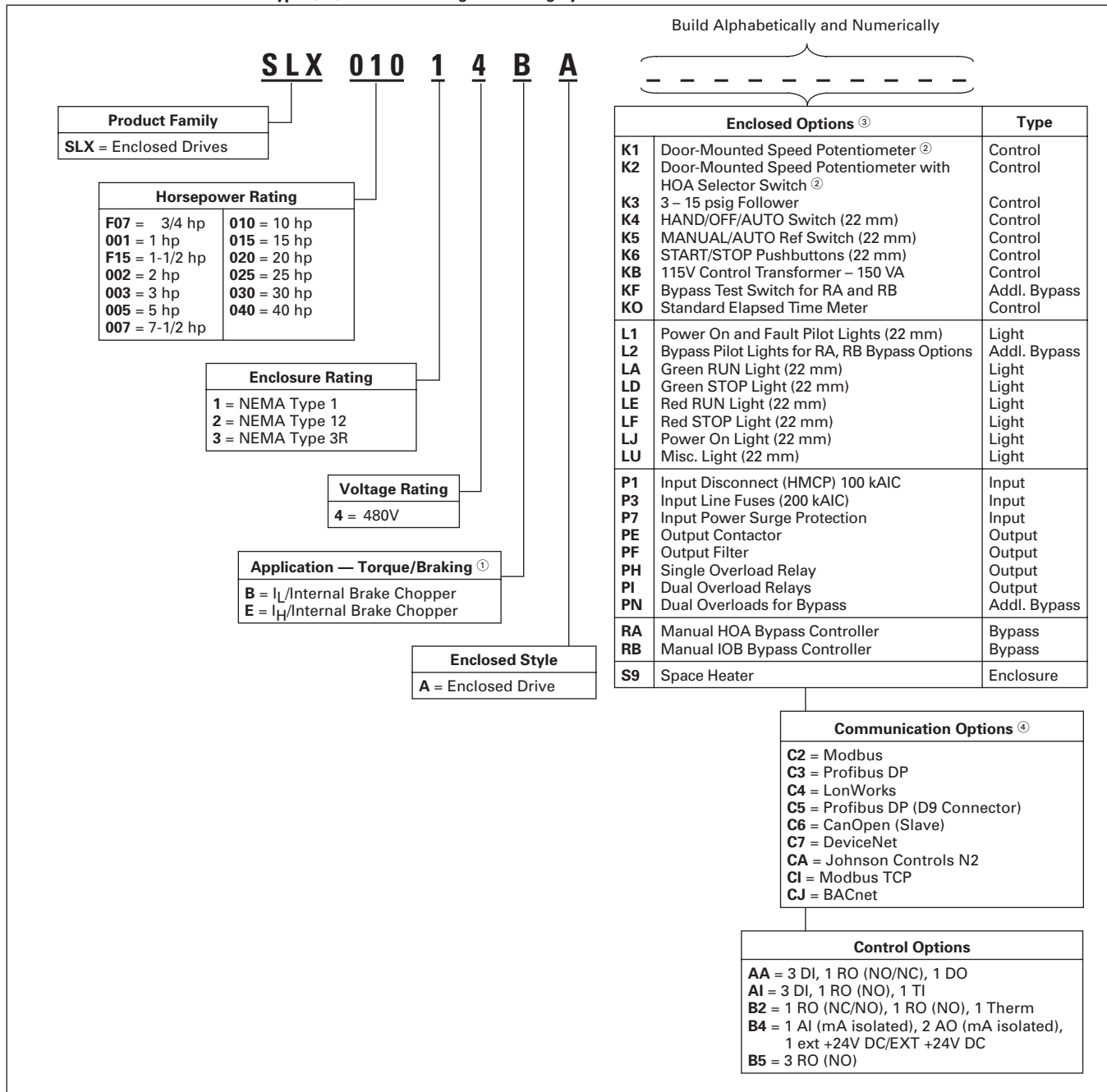

① Brake Chopper is factory installed standard. **Note:** External dynamic braking resistors not included. Consult factory.
 ② Includes local/remote speed reference switch.
 ③ See Pages 15 and 16 for descriptions.
 ④ See Pages 16 and 17 for complete descriptions.

June 2006

Enclosed Drives

Control/Communication Option Descriptions

Table 22. Available Control/Communications Options

Option	Description	Option Type
K1	Door-Mounted Speed Potentiometer — Provides the SLX9000 with the ability to adjust the frequency reference using a door-mounted potentiometer. This option uses the 10V DC reference to generate a 0 – 10V signal at the analog voltage input signal terminal. When the HOA bypass option is added, the speed is controlled when the HOA switch is in the hand position. Without the HOA bypass option, a 2-position switch (labeled local/remote) is provided on the keypad to select speed reference from the Speed Potentiometer or a remote speed signal.	Control
K2	Door-Mounted Speed Potentiometer with HOA Selector Switch — Provides the SLX9000 with the ability to start/stop and adjust the speed reference from door-mounted control devices or remotely from customer supplied inputs. In HAND position, the drive will start and the speed is controlled by the door-mounted speed potentiometer. The drive will be disabled in the OFF position. When AUTO is selected, the drive run and speed control commands are via user-supplied dry contact and 4 – 20 mA signal.	Control
K3	3 – 15 psig Follower — Provides a pneumatic transducer which converts a 3 – 15 psig pneumatic signal to either 0 – 8V DC or a 1 – 9V DC signal interface with the SLX9000.	Control
K4	HAND/OFF/AUTO Switch for Non-bypass Configurations — Provides a three-position selector switch that allows the user to select either a Hand or Auto mode of operation. Hand mode is defaulted to keypad operation, and Auto mode is defaulted to control from an external terminal source. These modes of operation can be configured via programming to allow for alternate combinations of start and speed sources. Start and speed sources include Keypad, I/O and FieldBus.	Control
K5	MANUAL/AUTO Speed Reference Switch — Provides a door-mounted selector switch for Manual/Auto speed reference.	Control
K6	START/STOP Pushbuttons — Provides door-mounted START and STOP pushbuttons for either bypass or non-bypass configurations.	Control
KB	115V Control Transformer – 150 VA — Provides a fused control power transformer with 115V for customer use.	Control
KF	Bypass Test Switch for RB and RA — Allows the user to energize the AF drive for testing while operating the motor on the bypass controller. The Test Switch is mounted on the inside of the enclosure door.	Addl. Bypass
KO	Standard Elapsed Time Meter — Provides a door-mounted elapsed run time meter.	Control
L1	Power On and Fault Pilot Lights (22 mm) — Provides a white power on light that indicates power to the enclosed cabinet and a red fault light indicates a drive fault has occurred.	Light
L2	Bypass Pilot Lights for RB, RA Bypass Options — A green light indicates when the motor is running in inverter mode and an amber light indicates when the motor is running in bypass mode. The lights are mounted on the enclosure door, above the switches.	Addl. Bypass
LA	Green RUN Light (22 mm) — Provides a green run light that indicates the drive is running.	Light
LD	Green STOP Light (22 mm) — Provides a green stop light that indicates the drive is stopped.	Light
LE	Red Run Pilot Light (22 mm) — Provides a red run pilot light that indicates the drive is running.	Light
LF	Red STOP Light (22 mm) — Provides a red stop light that indicates the drive is stopped.	Light
LJ	Power On Light (22 mm) — Provides a white power on light that indicates the drive enclosure power is on.	Light
LU	Misc. Light (22 mm) — Provides a misc. "user defined" pilot light. User to define light function and color.	Light
P1	Input Disconnect Assembly Rated to 100 kAIC — High Interruption Circuit Breaker that provides a means of short circuit protection for the power cables between it and the SLX9000, and protection from high-level ground faults on the power cable. Allows a convenient means of disconnecting the SLX9000 from the line and the operating mechanism can be padlocked in the OFF position. This is factory mounted in the enclosure.	Input
P3	Input Line Fuses Rated to 200 kAIC — Provides high-level fault protection of the SLX9000 input power circuit from the load side of the fuses to the input side of the power transistors. This option consists of three 200 kA fuses, which are factory mounted in the enclosure.	Input
P5	5% Input Reactance — Add additional input reactance to increase total from 3% standard to optional 5%.	Input
P7	MOV Surge Suppressor — Provides a Metal Oxide Varistor (MOV) connected to the line side terminals and is designed to clip line side transients.	Input
PE	Output Contactor — Provides a means for positive disconnection of the drive output from the motor terminals. The contactor coil is controlled by the drive's run or permissive logic. NC and NO auxiliary contacts rated at 10A, 600V AC are provided for customer use. Bypass Options RB and RA include an Output Contactor as standard. This option includes a low VA 115V AC fused Control Power Transformer and is factory mounted in the enclosure.	Output
PF	Output Filter — Used to reduce the transient voltage (DV/DT) at the motor terminals. The Output Filter is recommended for cable lengths exceeding 100 ft. (30m) with a drive of 3 hp and above, for cable lengths of 33 ft. (10m) with a drive of 2 hp and below, or for a drive rated at 525 – 690V. This option is mounted in the enclosure, and may be used in conjunction with a Brake Chopper Circuit.	Output
PH	Single Overload Relay — Uses a bimetallic overload relay to provide additional overload current protection to the motor on configurations without bypass options. It is included with the Bypass Configurations for overload current protection in the bypass mode. The Overload Relay is mounted within the enclosure, and is manually resettable. Heater pack included.	Output
PI	Dual Overload Relays — This option is recommended when a single drive is operating 2 motors and overload current protection is needed for each of the motors. The standard configuration includes two bimetallic overload relays, each sized to protect a motor with 50% of the drive hp rating. For example, a 100 hp drive would include two overload relays sized to protect two 50 hp motors. The relays are mounted within the enclosure, and are manually resettable. Heater packs not included.	Output
PN	Dual Overloads for Bypass — This option is recommended when a single drive is operating 2 motors in the bypass mode and overload current protection is needed for each of the motors. The standard configuration includes two bimetallic overload relays, each sized to protect a motor with 50% of the drive hp rating. For example, a 100 hp drive would include two overload relays sized to protect two 50 hp motors. The relays are mounted within the enclosure, and are manually resettable.	Addl. Bypass

Enclosed Drives

Table 22. Available Control/Communications Options (Continued)

Option	Description	Option Type
RA	Manual HOA Bypass Controller — The Manual HAND/OFF/AUTO (HOA) — 3-contactor — bypass option provides a means of bypassing the SLX9000, allowing the AC motor to be operated at full speed directly from the AC supply line. This option consists of an input disconnect, a fused control power transformer, and a full voltage bypass starter with a door mounted HOA selector switch and an INVERTER/BYPASS switch. The HOA switch provides the ability to start and stop the drive in the inverter mode. A Freedom Series IEC input contactor, a Freedom Series IEC output contactor, and a Freedom Series IEC starter with a bimetallic overload relay is included. The contactors are mechanically and electrically interlocked (see power diagram on Page 12).	Bypass
RB	Manual IOB Bypass Controller — The Manual INVERTER/OFF/BYPASS (IOB) — 3-contactor — bypass option provides a means of bypassing the SLX9000, allowing the AC motor to be operated at full speed directly from the AC supply line. This option consists of an input disconnect, a fused control power transformer, and a full voltage bypass starter with a door mounted IOB selector switch. A Freedom Series IEC input contactor, a Freedom Series IEC output contactor, and a Freedom Series IEC starter with a bimetallic overload relay is included. The contactors are mechanically and electrically interlocked (see power diagram on Page 12).	Bypass
S9	Space Heater — Prevents condensation from forming in the enclosure when the drive is inactive or in storage. Includes a thermostat for variable temperature control. Requires a customer supplied 115V remote supply source.	Enclosure

Note: For availability, see Product Selection for base drive voltage required.

SLX9000 Series Option Board Kits

The SLX9000 Series drives can accommodate a wide selection of expander and adapter option boards to customize the drive for your application needs. The drive's control unit is designed to accept a total of two option boards (see Figure 5).

The SLX9000 Drive accommodates the standard I/O and an integrated RS-485 (Modbus) connector.

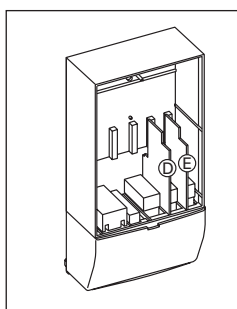

Figure 5. 9000X Series Option Boards

Table 23. I/O Specifications for the Control/Communication Options

Description	Specifications
Analog voltage, input	0 – ±10V, R _i ≥ 200 kΩ
Analog current, input	0 (4) – 20 mA, R _i = 250 Ω
Digital Input	24V: "0" ≤ 10V, "1" ≥ 18V, R _i > 5 kΩ
Aux. voltage	24V (±20%), max. 50 mA
Reference voltage	10V ±3%, max. 10 mA
Analog current, output	0 (4) – 20 mA, R _L = 500 kΩ, resolution 10 bit, accuracy ≤ ±2%
Relay output	300V DC, 250V AC
Max. switching voltage	8A/24V DC, .4A/300V DC, 2 kVA/250V AC
Max. switching load	2A rms
Max. continuous load	
Thermistor input	R _{trip} = 4.7 kΩ

Table 24. Option Board Kits

Option Kit Description ②	Allowed Slot Locations ①	Field Installed		Factory Installed		SLX9000 Programs
		Catalog Number	Price U.S. \$	Option Designator	Adder U.S. \$	
Extended I/O Card Options						
3 DI, 1 RO (NO/NC), 1 DO	D	OPTAA	150.	AA	255.	X
3 DI, 1 RO (NO), 1 TI	D	OPTAI	150.	AI	255.	X
1 RO (NC/NO), 1 RO (NO), 1 Therm	D, E	OPTB2	221.	B2	326.	X
1 AI (mA isolated), 2 AO (mA isolated), 1 ext +24V DC/EXT +24V DC	D, E	OPTB4	336.	B4	441.	X
3 RO (NO)	D, E	OPTB5	200.	B5	305.	X
Communication Cards						
Johnson Controls N2	D, E	OPTC2	237.	CA	342.	X
Modbus	D, E	OPTC2	237.	C2	342.	X
Modbus TCP	D, E	OPTCI	590.	CI	695.	X
BACnet	D, E	OPTCJ	280.	CJ	385.	X
Profibus DP	D, E	OPTC3	431.	C3	540.	X
LonWorks	D, E	OPTC4	580.	C4	685.	X
Profibus DP (D9 Connector)	D, E	OPTC5	580.	C5	685.	X
CanOpen (Slave)	D, E	OPTC6	580.	C6	685.	X
DeviceNet	D, E	OPTC7	580.	C7	685.	X
Keypad						
SLX9000 Series LCD Keypad (Replacement Keypad)		Keypad-LCD	150.	—	—	X
SLX9000 Series Remote Mount Keypad Unit (Keypad not included, includes 6.5 ft. cable, keypad holder, mounting hardware)		OPTDRA-02L	200.	—	—	X

① Option card must be installed in one of the slots listed for that card. Slot indicated in **Bold** is the preferred location.

② AI = Analog Input; AO = Analog Output, DI = Digital Input, DO = Digital Output, RO = Relay Output

Discount Symbol..... SS-3

Johnson Controls Metasys™ N2 Network Communications

The OPTC2 fieldbus board provides communication between the SLX9000 drive and a Johnson Controls Metasys™ N2 network. With this connection, the drive can be controlled, monitored and programmed from the Metasys system. The N2 fieldbus is available as a factory installed option and as a field installable kit.

Modbus RTU Network Communications

The Modbus Network Card OPTC2 is used for connecting the 9000X Drive as a slave on a Modbus network. The interface is connected by a 9-pin DSUB connector (female) and the baud rate ranges from 300 to 19200 baud. Other communication parameters include an address range from 1 to 247; a parity of None, Odd or Even; and the stop bit is 1.

Modbus/TCP Network Communications

The Modbus/TCP Network Card OPTC1 is used for connecting the 9000X Drive to Ethernet networks utilizing Modbus protocol. It includes an RJ-45 pluggable connector. This interface provides a selection of standard and custom register values to communicate drive parameters. The board supports 10 Mbps and 100 Mbps communication speeds. The IP address of the board is configurable over Ethernet using a supplied software tool.

BACnet Network Communications

The BACnet Network Card OPTCJ is used for connecting the 9000X Drive to BACnet networks. It includes a 5.08 mm pluggable connector. Data transfer is Master-Slave/Token Passing (MS/TP) RS-485. This interface uses a collection of 30 Binary Value Objects (BVOs) and 35 Analog Value Objects (AVOs) to communicate drive parameters. The card supports

9.6, 19.2 and 38.4 Kbaud communication speeds and supports network addresses 1 – 127.

Profibus Network Communications

The Profibus Network Card OPTC3 is used for connecting the SLX9000 as a slave on a Profibus-DP network. The interface is connected by a 9-pin DSUB connector (female). The baud rates range from 9.6K baud to 12M baud, and the addresses range from 1 to 127.

LonWorks Network Communications

The LonWorks Network Card OPTC4 is used for connecting the SLX9000 on a LonWorks network. This interface uses Standard Network Variable Types (SNVT) as data types. The channel connection is achieved using a FTT-10A Free Topology transceiver via a single twisted transfer cable. The communication speed with LonWorks is 78 kBits/s.

CanOpen (Slave) Communications

The CanOpen (Slave) Network Card OPTC6 is used for connecting the SLX9000 to a host system. According to ISO11898 standard cables to be chosen for CAN bus should have a nominal impedance of 120Ω, and specific line delay of nominal 5 nS/m. 120Ω line termination resistors required for installation.

DeviceNet Network Communications

The DeviceNet Network Card OPTC7 is used for connecting the SLX9000 on a DeviceNet Network. It includes a 5.08 mm pluggable connector. Transfer method is via CAN using a 2-wire twisted shielded cable with 2-wire bus power cable and drain. The baud rates used for communication include 125K baud, 250k baud and 500K baud.

Product Selection

When Ordering

- Select a Base Catalog Number that meets the application requirements — nominal horsepower, voltage and enclosure rating (the enclosed drive's continuous output amp rating should be equal to or greater than the motor's full load amp rating). The base enclosed package includes a standard drive, door mounted Local/Remote Keypad and enclosure.
- If Control/Communication option is desired, change the appropriate code in the Base Catalog Number.
- Select Enclosed Options. Add the codes as suffixes to the Base Catalog Number in alphabetical and numeric order.
- Read all Footnotes.

480V Drives

Table 25. 480V AC Input Base Drive

Enclosure Size ①	hp	Current (A)	NEMA Type 1			NEMA Type 12			NEMA Type 3R		
			Frame Size	Base Catalog Number ②	Price U.S. \$ ③	Frame Size	Base Catalog Number ②	Price U.S. \$ ③	Frame Size	Base Catalog Number ②	Price U.S. \$ ③
High Overload Drive and Enclosure											
MF0	1	2.2	MF4	SLX00114EA	2,255.	MF4	SLX00124EA		MF4	SLX00134EA	
	1-1/2	3.3	MF4	SLXF1514EA	2,305.	MF4	SLXF1524EA		MF4	SLXF1534EA	
	2	4.3	MF4	SLX00214EA	2,395.	MF4	SLX00224EA		MF4	SLX00234EA	
	3	5.6	MF4	SLX00314EA	2,500.	MF4	SLX00324EA		MF4	SLX00334EA	
	5	7.6	MF4	SLX00514EA	2,575.	MF4	SLX00524EA		MF4	SLX00534EA	
MF1	7-1/2	12	MF5	SLX00714EA	2,785.	MF5	SLX00724EA		MF5	SLX00734EA	
	10	16	MF5	SLX01014EA	3,155.	MF5	SLX01024EA		MF5	SLX01034EA	
	15	23	MF5	SLX01514EA	3,795.	MF5	SLX01524EA		MF5	SLX01534EA	
MF2	20	31	MF6	SLX02014EA	4,905.	MF6	SLX02024EA		MF6	SLX02034EA	
	25	38	MF6	SLX02514EA	5,655.	MF6	SLX02524EA		MF6	SLX02534EA	
	30	46	MF6	SLX03014EA	6,485.	MF6	SLX03024EA		MF6	SLX03034EA	
Low Overload Drive and Enclosure											
MF0	1-1/2	3.3	MF4	SLXF1514BA	2,255.	MF4	SLXF1524BA		MF4	SLXF1534BA	
	2	4.3	MF4	SLX00214BA	2,305.	MF4	SLX00224BA		MF4	SLX00234BA	
	3	5.6	MF4	SLX00314BA	2,395.	MF4	SLX00324BA		MF4	SLX00334BA	
	5	7.6	MF4	SLX00514BA	2,500.	MF4	SLX00524BA		MF4	SLX00534BA	
	7-1/2	12	MF4	SLX00714BA	2,575.	MF4	SLX00724BA		MF4	SLX00734BA	
MF1	10	16	MF5	SLX01014BA	2,785.	MF5	SLX01024BA		MF5	SLX01034BA	
	15	23	MF5	SLX01514BA	3,155.	MF5	SLX01524BA		MF5	SLX01534BA	
	20	31	MF5	SLX02014BA	3,795.	MF5	SLX02024BA		MF5	SLX02034BA	
MF2	25	38	MF6	SLX02514BA	4,905.	MF6	SLX02524BA		MF6	SLX02534BA	
	30	46	MF6	SLX03014BA	5,655.	MF6	SLX03024BA		MF6	SLX03034BA	
	40	61	MF6	SLX04014BA	6,485.	MF6	SLX04024BA		MF6	SLX04034BA	

① Enclosure dimensions listed on Pages 19 – 23.

② Includes drive, keypad and enclosure.

③ Consult Eaton for pricing and availability.

Enclosed Drives

Table 26. 480V Control Options

Catalog Number Suffix	Door-Mounted Speed Potentiometer	Door-Mounted Speed Potentiometer with HOA Selector Switch	3 – 15 psig Follower	HAND/OFF/AUTO Switch (22 mm)	MANUAL/AUTO Ref Switch (22 mm)	START/STOP Pushbuttons (22 mm)	115 Volt Control Transformer 150 VA	Standard Elapsed Time Meter
K1	K2	K3	K4	K5	K6	KB	KO	
hp	Adder U.S. \$	Adder U.S. \$	Adder U.S. \$	Adder U.S. \$	Adder U.S. \$	Adder U.S. \$	Adder U.S. \$	Adder U.S. \$
1 – 40	200.	263.	750.	200.	130.	360.	473.	405.

Table 27. 480V Light Options

Catalog Number Suffix	Power On/Fault Pilot Lights (22 mm)	Green RUN Light (22 mm)	Green STOP Light (22 mm)	Red RUN Light (22 mm)	Red STOP Light (22 mm)	Power On Light (22 mm)	Misc Light (22 mm)
L1	LA	LD	LE	LF	LJ	LU	
hp	Adder U.S. \$	Adder U.S. \$	Adder U.S. \$	Adder U.S. \$	Adder U.S. \$	Adder U.S. \$	Adder U.S. \$
1 – 40	560.	190.	190.	190.	190.	190.	200.

Table 28. 480V Bypass Options

Catalog Number Suffix	Bypass Test Switch for RA, RB	Bypass Pilot Lights for RA, RB Options	Dual Overloads for Bypass	Manual HOA Bypass Controller	Manual IOB Bypass Controller
KF	L2	PN	RA	RB	
hp	Adder U.S. \$	Adder U.S. \$	Adder U.S. \$	Adder U.S. \$	Adder U.S. \$
1 – 20	200.	200.	147.	1,810.	1,410.
25	200.	200.	147.	1,995.	1,600.
30	200.	200.	147.	2,100.	1,705.
40	200.	200.	168.	2,165.	1,765.

① See Pages 15 and 16 for details.

Table 29. 480V Enclosure Options

Catalog Number Suffix	Space Heater
S9	
Enclosure Size	Adder U.S. \$
MFO – MF2	336. ③

② Requires customer supplied 115V AC supply.

③ 200 watt.

Table 30. 480V Power Options

Catalog Number Suffix	Input				Output			
	Input Disconnect (HMCP) 100 kAIC	Input Line Fuses 200 kAIC	5% Input Reactance	Input Power Surge Protection	Output Contactor	Output Filter	Single Overload Relay ④	Dual Overload Relays ④
P1	P3	P5	P7	PE	PF	PH	PI	
hp	Adder U.S. \$	Adder U.S. \$	Adder U.S. \$	Adder U.S. \$	Adder U.S. \$	Adder U.S. \$	Adder U.S. \$	Adder U.S. \$
1 – 2	525.	263.	995.	500.	210.	399.	147.	294.
3 – 5	525.	263.	995.	500.	210.	452.	147.	294.
7-1/2	525.	263.	995.	500.	210.	525.	147.	294.
10	525.	263.	1,245.	500.	210.	550.	147.	294.
15	525.	315.	1,245.	500.	242.	560.	147.	294.
20	525.	315.	1,245.	500.	242.	665.	147.	294.
25	580.	420.	1,245.	500.	305.	665.	147.	294.
30	580.	420.	1,245.	500.	305.	750.	147.	294.
40	580.	420.	1,245.	500.	441.	790.	168.	336.

④ Heater packs not included.

Discount Symbol..... SS-2

June 2006

Enclosed Drives

Dimensions

Enclosure Size MF0 without Filter

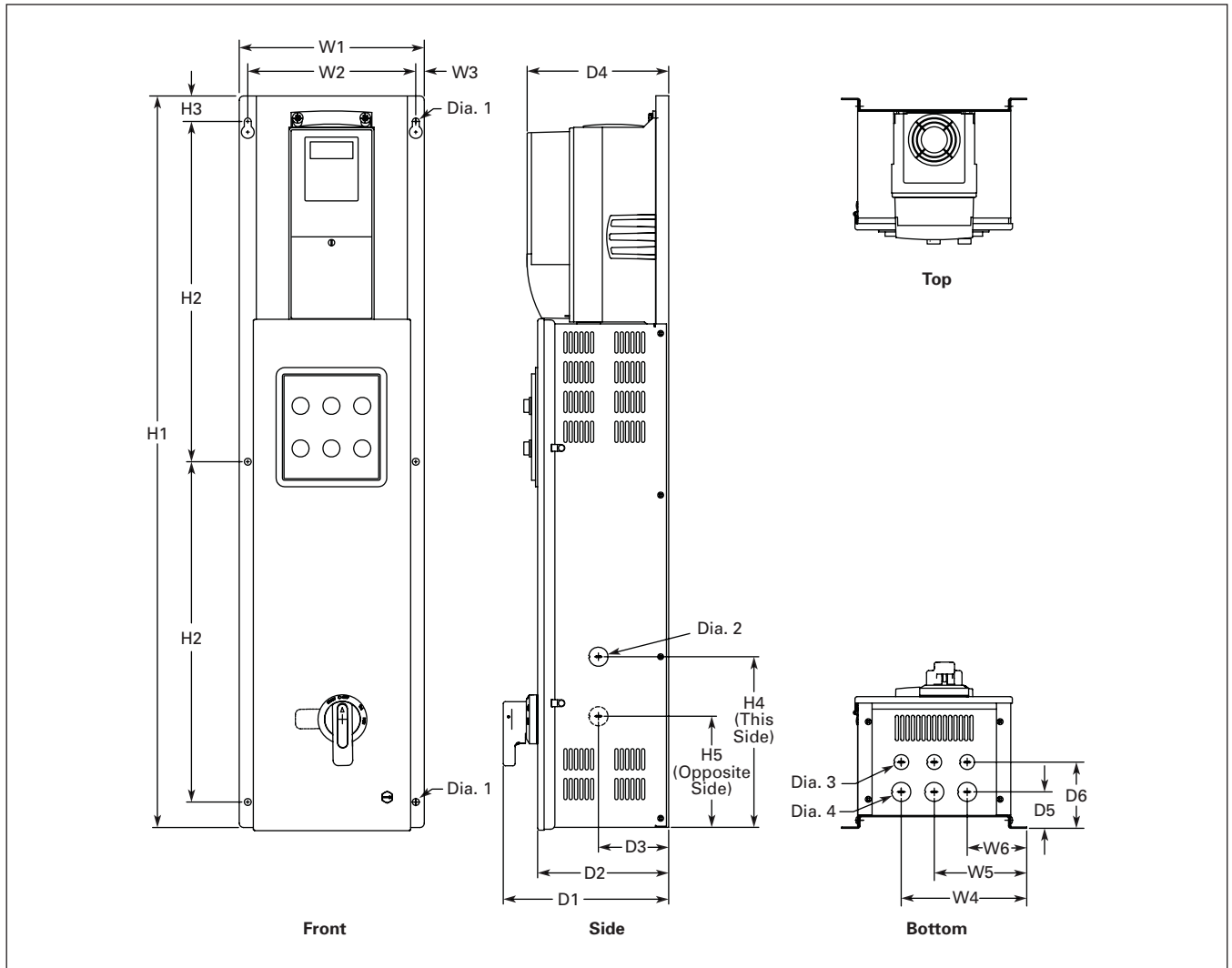

Figure 6. Approximate Dimensions

Table 31. Approximate Dimensions and Shipping Weight — Enclosed Products

Voltage AC	hp (I _H)	hp (I _L)	Approximate Dimensions in Inches (mm)										
			H1	H2	H3	H4	H5	W1	W2	W3	W4	W5	W6
480V	1 – 5	1-1/2 – 7-1/2	43.00 (1092)	20.00 (508)	1.50 (38)	10.03 (255)	6.53 (166)	10.88 (276)	9.87 (251)	.50 (13)	7.38 (187)	5.44 (138)	3.50 (89)

Table 31. Approximate Dimensions and Shipping Weight — Enclosed Products (Continued)

Voltage AC	hp (I _H)	hp (I _L)	Approximate Dimensions in Inches (mm)										Max. Approx. Wt. Lbs. (kg)
			D1	D2	D3	D4	D5	D6	Dia. 1	Dia. 2	Dia. 3	Dia. 4	
480V	1 – 5	1-1/2 – 7-1/2	9.72 (247)	7.70 (195)	4.13 (105)	8.31 (211)	3.89 (99)	2.14 (54)	.41 (10)	1.12 (29)	.88 (22)	1.13 (29)	49 (22)

Enclosed Drives

Enclosure Size MF0 with Filter

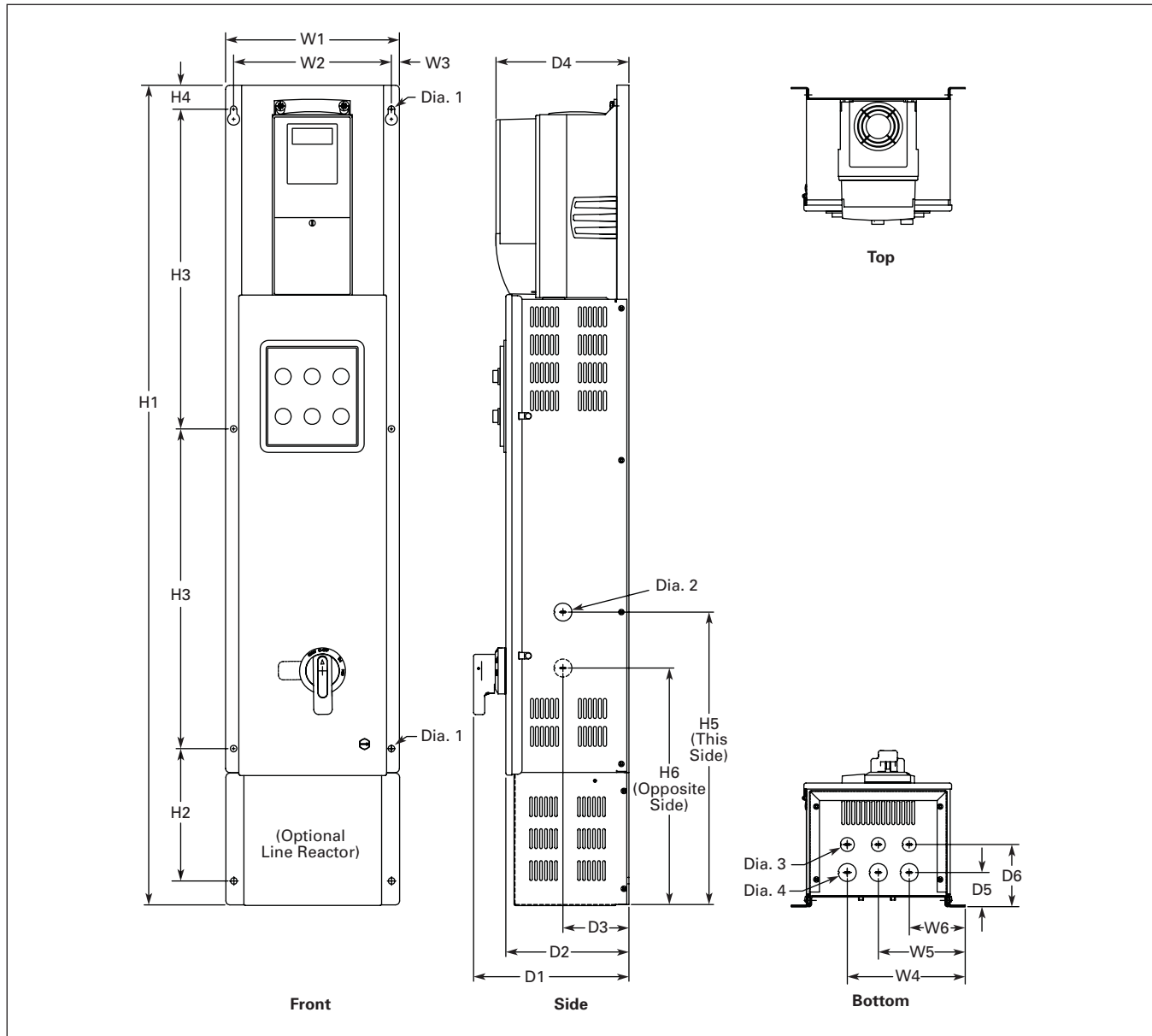

Figure 7. Approximate Dimensions

Table 32. Approximate Dimensions and Shipping Weight — Enclosed Products

Voltage AC	hp (I _H)	hp (I _L)	Approximate Dimensions in Inches (mm)											
			H1	H2	H3	H4	H5	H6	W1	W2	W3	W4	W5	W6
480V	1 – 5	1-1/2 – 7-1/2	51.28 (1303)	8.28 (210)	20.00 (508)	1.50 (38)	18.30 (465)	14.80 (378)	10.88 (276)	9.87 (251)	.50 (13)	7.38 (187)	5.44 (138)	3.50 (89)

Table 32. Approximate Dimensions and Shipping Weight — Enclosed Products (Continued)

Voltage AC	hp (I _H)	hp (I _L)	Approximate Dimensions in Inches (mm)										Max. Approx. Wt. Lbs. (kg)
			D1	D2	D3	D4	D5	D6	Dia. 1	Dia. 2	Dia. 3	Dia. 4	
480V	1 – 5	1-1/2 – 7-1/2	9.72 (247)	77.70 (195)	4.13 (105)	8.31 (211)	3.89 (99)	2.14 (54)	.41 (10)	1.12 (29)	.88 (22)	1.13 (29)	49 (22)

June 2006

Enclosed Drives

Enclosure Size MF1 without Filter

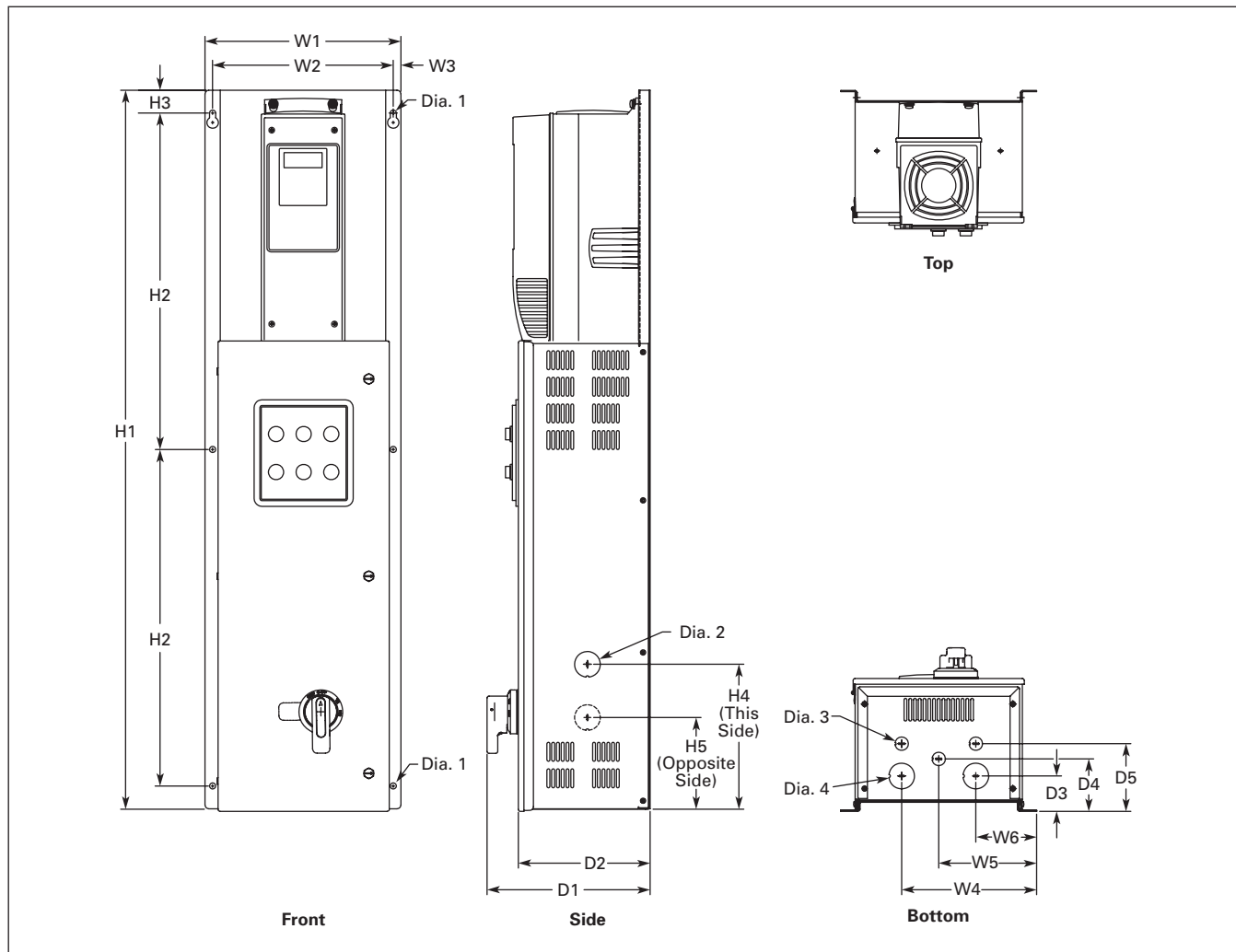

Figure 8. Approximate Dimensions

Table 33. Approximate Dimensions and Shipping Weight — Enclosed Products

Voltage AC	hp (I _H)	hp (I _L)	Approximate Dimensions in Inches (mm)										
			H1	H2	H3	H4	H5	W1	W2	W3	W4	W5	W6
480V	7-1/2 – 15	10 – 20	47.25 (1200)	22.13 (562)	1.50 (38)	9.50 (241)	6.00 (152)	12.87 (327)	11.87 (302)	.50 (13)	8.88 (225)	6.44 (164)	4.00 (102)

Table 33. Approximate Dimensions and Shipping Weight — Enclosed Products (Continued)

Voltage AC	hp (I _H)	hp (I _L)	Approximate Dimensions in Inches (mm)										Max. Approx. Wt. Lbs. (kg)
			D1	D2	D3	D4	D5	Dia. 1	Dia. 2	Dia. 3	Dia. 4		
480V	7-1/2 – 15	10 – 20	10.72 (272)	8.67 (220)	2.51 (64)	3.64 (92)	4.64 (118)	.41 (10)	1.69 (43)	.88 (22)	1.69 (43)	67 (30)	

Enclosed Drives

Enclosure Size MF1 with Filter

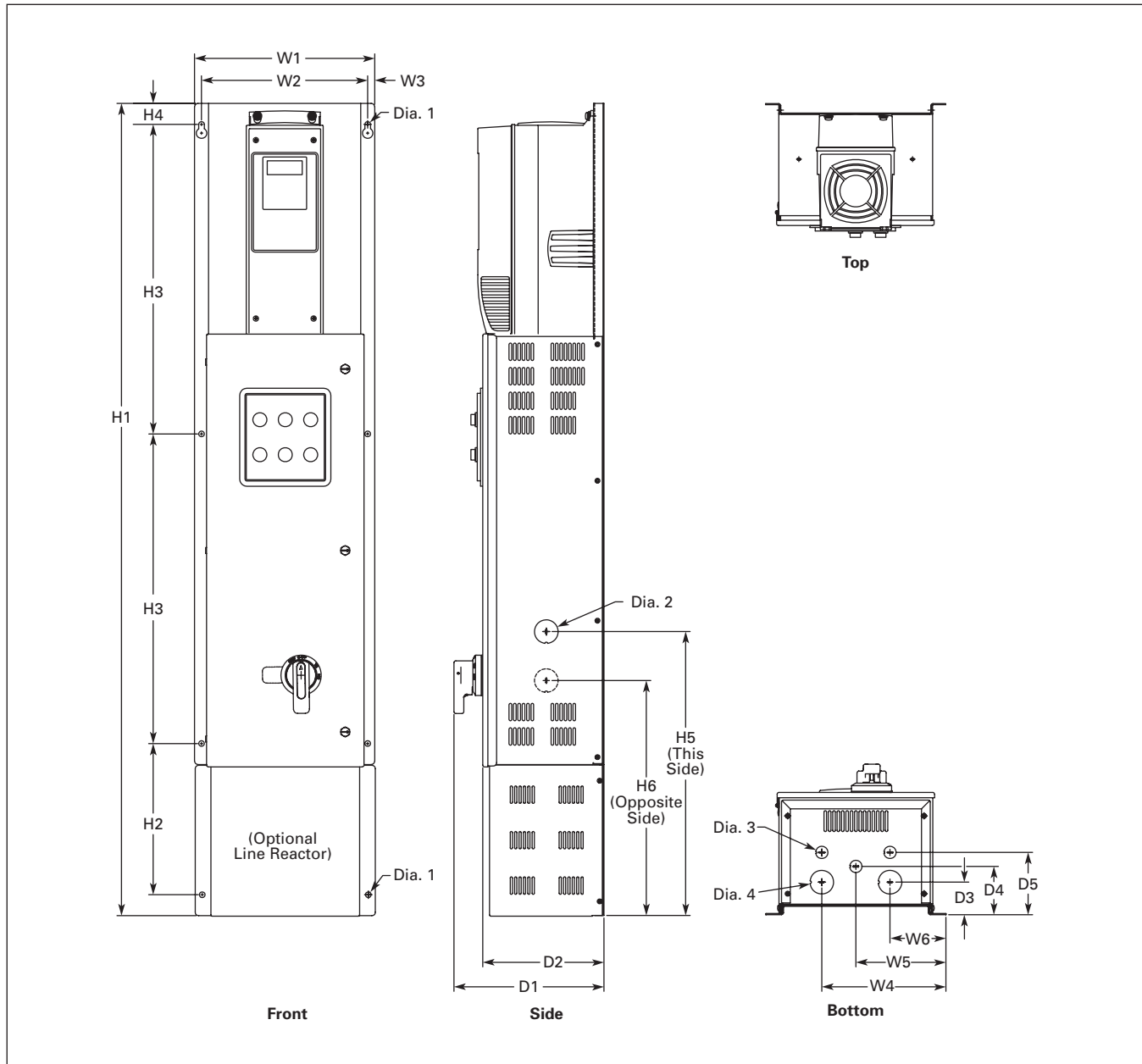

Figure 9. Approximate Dimensions

Table 34. Approximate Dimensions and Shipping Weight — Enclosed Products

Voltage AC	hp (I _H)	hp (I _L)	Approximate Dimensions in Inches (mm)											
			H1	H2	H3	H4	H5	H6	W1	W2	W3	W4	W5	W6
480V	7-1/2 – 15	10 – 20	58.05 (1475)	10.80 (274)	22.13 (562)	1.50 (38)	20.28 (515)	16.78 (426)	12.87 (327)	11.87 (302)	.50 (13)	8.88 (225)	6.44 (164)	4.00 (102)

Table 34. Approximate Dimensions and Shipping Weight — Enclosed Products (Continued)

Voltage AC	hp (I _H)	hp (I _L)	Approximate Dimensions in Inches (mm)										Max. Approx. Wt. Lbs. (kg)
			D1	D2	D3	D4	D5	Dia. 1	Dia. 2	Dia. 3	Dia. 4		
480V	7-1/2 – 15	10 – 20	10.72 (272)	8.67 (220)	2.32 (59)	3.45 (88)	4.45 (113)	.41 (10)	1.69 (43)	.88 (22)	1.69 (43)	67 (30)	

June 2006

Enclosed Drives

Enclosure Size MF2

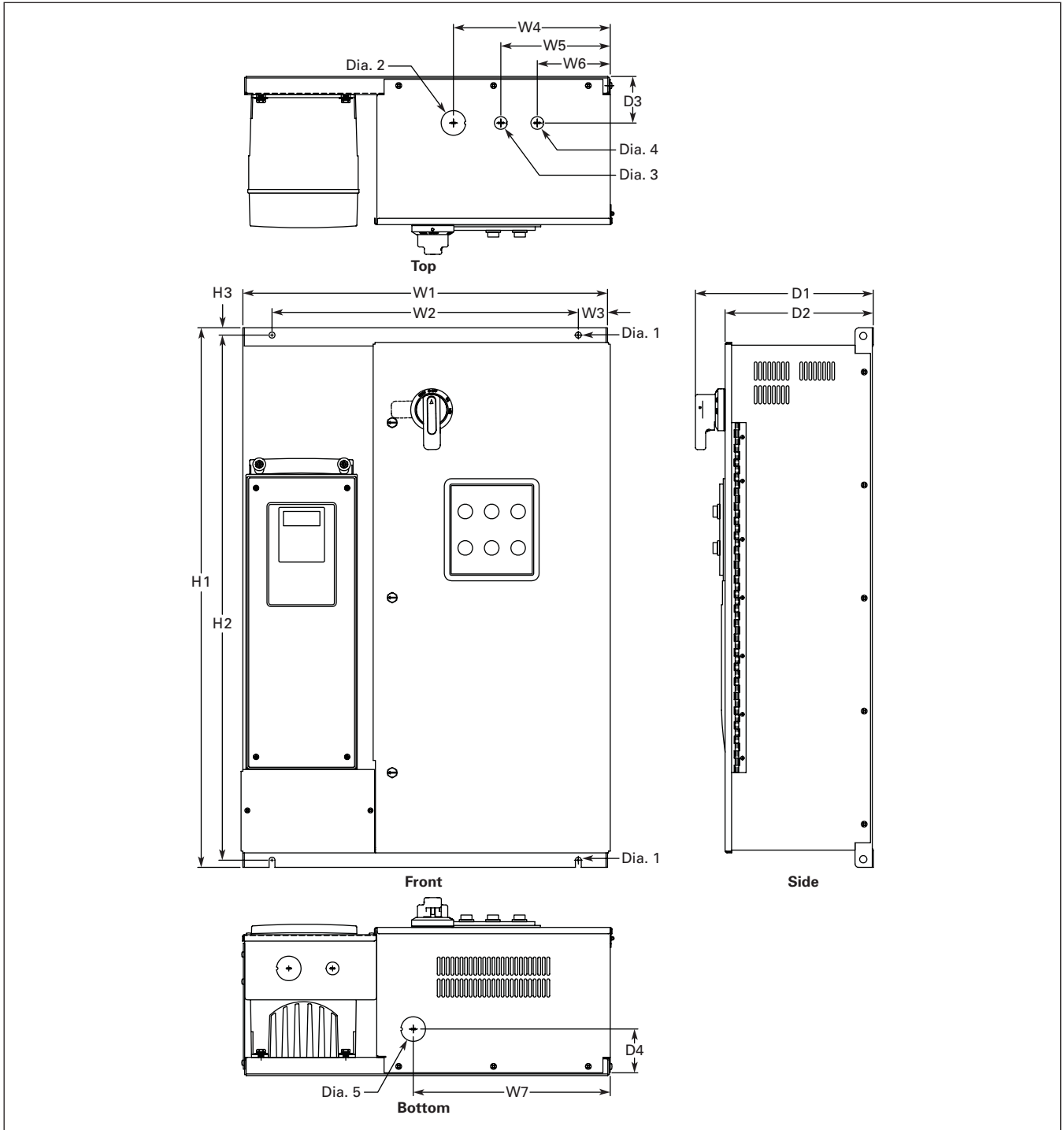

Figure 10. Approximate Dimensions

Table 35. Approximate Dimensions and Shipping Weight — Enclosed Products

Voltage AC	hp (I _H)	hp (I _L)	Approximate Dimensions in Inches (mm)																		Max. Approx. Wt. Lbs. (kg)	
			H1	H2	H3	W1	W2	W3	W4	W5	W6	W7	D1	D2	D3	D4	Dia. 1	Dia. 2	Dia. 3	Dia. 4		Dia. 5
480V	20 – 30	25 – 40	37.00 (940)	36.00 (914)	.50 (13)	25.00 (635)	21.00 (533)	2.00 (51)	10.69 (271)	7.44 (189)	4.94 (125)	13.44 (341)	12.19 (310)	10.16 (258)	3.19 (81)	3.12 (79)	.41 (10)	1.69 (43)	.87 (22)	.88 (22)	1.69 (43)	126 (57)

Eaton Electrical Inc.
1000 Cherrington Parkway
Moon Township, PA 15108-4312
USA
tel: 1-800-525-2000
www.EatonElectrical.com



Cutler-Hammer

© 2006 Eaton Corporation
All Rights Reserved
Printed in USA
Publication No. CA04000004E/CPG
June 2006