

# Water Separator

# Series AMG

The AMG series water separator is installed on the air pressure line to remove water drops in the compressed air. It is suitable for use in cases where “water must be removed, but the air does not have to be as dry as when an air dryer is used” or “an air dryer cannot be used because an electric power supply is not available”.

Through the adoption of an element that is used exclusively for removing water drops and the provision of ample housing interior space, a 99%\* water removal rate\*\* has been achieved.

## Caution

Water separator can remove water droplets, but it cannot remove moisture.

- \*Condition of inlet air
  - Pressure: 0.7 MPa
  - Temperature: 25°C
  - Relative humidity: 100%
  - Liquid water content (Water droplet content): 1.5 g/m<sup>3</sup> (ANR)
  - Compressed air flow: Rated flow of each model
- \*\*Removed rate of water (%) =  $\frac{\text{Removed water (Water droplet) (g)}}{\text{Inflowed water (Water droplet) (g)}} \times 100$

Various equipment for drain discharge

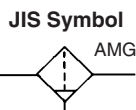

**Made to Order Specifications**  
(For details, refer to page 14-20-55.)

## Caution

Be sure to read before handling. Refer to pages 14-21-3 to 4 for Safety Instructions and Common Precautions on the products mentioned in this catalog, pages 14-14-6 to 8 for Precautions on every series, and pages 14-20-62 to 64 for more detailed precautions on every series.

## Model

Model	AMG150	AMG250	AMG350	AMG450	AMG550	AMG650	AMG850
Rated flow (ℓ/min (ANR)) <small>Note</small>	300	750	1500	2200	3500	6000	12000
Port size (Nominal size B)	1/8, 1/4, 3/8	1/4, 3/8, 1/2	3/8, 1/2, 3/4	1/2, 3/4, 1	3/4, 1	1, 1 1/2	1 1/2, 2
Weight (kg)	0.38	0.55	0.9	1.4	2.1	4.2	10.5

 Note) Max. flow capacity at a pressure of 0.7 MPa. Max. flow varies depending on operating pressure. Refer to page 14-20-4 for flow rate and page 14-20-4 for the max. flow line graph.

## Specifications

Fluid	Compressed air
Max. operating pressure	1.0 MPa
Min. operating pressure *	0.05 MPa
Proof pressure	1.5 MPa
Ambient and fluid temperature	5 to 60°C
Removed rate of water	99%
Element life	2 years or when pressure drop reaches 0.1 MPa

\* 0.1 MPa (N.O. type) or 0.15 MPa (N.C. type) in the case of types with auto-drain.

 Refer to “Made to Order Specifications” on page 14-20-55.

## Accessory (Option)

Applicable model	AMG150	AMG250	AMG350	AMG450	AMG550	AMG650	AMG850
Bracket assembly (With cap bolt and spring washer)	BM51	BM52	BM53	BM54	BM55	BM56	BM57

## How to Order

AMG 250 03 B J

### Body size

150	1/8 Standard
250	1/4 Standard
350	3/8 Standard
450	1/2 Standard
550	3/4 Standard
650	1 Standard
850	1 1/2 Standard

### Thread type

Nil	Rc
F	G
N	NPT

### Port size

01	1/8 <sup>B</sup>	06	3/4 <sup>B</sup>
02	1/4 <sup>B</sup>	10	1 <sup>B</sup>
03	3/8 <sup>B</sup>	14	1 1/2 <sup>B</sup>
04	1/2 <sup>B</sup>	20	2 <sup>B</sup>

### Option \*

J	Drain guide 1/4 <sup>B</sup> female thread
R	IN-OUT reversal direction

Note) Element service indicator (symbol: T) is not available as an option because water deposits inside the indicator will lead to malfunctions.

### Accessory (Option) \*

Symbol	Description
Nil	—
B	Bracket
C	N.C. auto-drain
D	N.O. auto-drain

\* Refer to the table below for accessory/Option combinations.



Note) Refer to “How to Order Bowl Assembly” on page 14-20-59.

HA

AT

ID

AMG

AFF

AM

Misc.

## Accessory/Option Combinations

○ Available  Not available ○ Depends on model

Accessory (Option)	Accessory	Option specifications	Applicable model											
			C	D	J	R	AMG150	AMG250	AMG350	AMG450	AMG550	AMG650	AMG850	
Accessory	N.C. auto-drain	C												
	N.O. auto-drain	D												
Option	Drain guide 1/4 B	-J												
	IN-OUT reversal direction	-R	○	○	○									

# Series AMG

## Flow Characteristics

Element initial condition



Note) Compressed air over max. flow line in the table below may not meet the specifications of the product. It may cause damage to the element.

**AMG150**

1/8 B

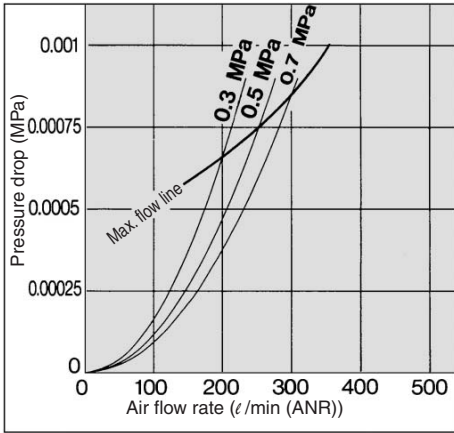

**AMG450**

1/2 B

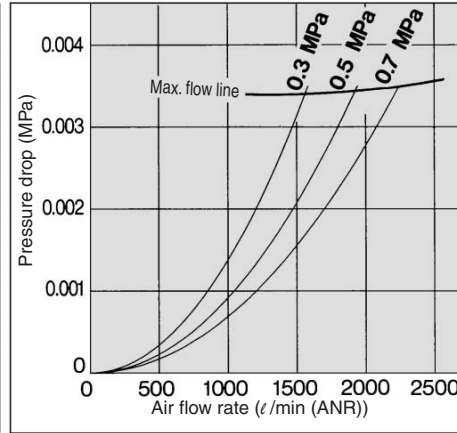

**AMG850**

1 1/2 B

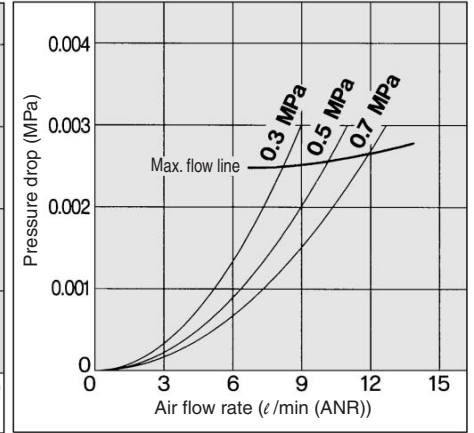

**AMG250**

1/4 B

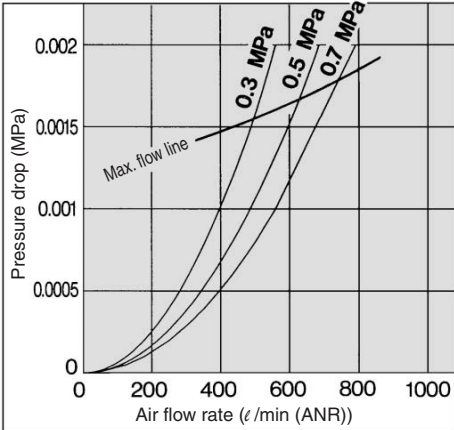

**AMG550**

3/4 B

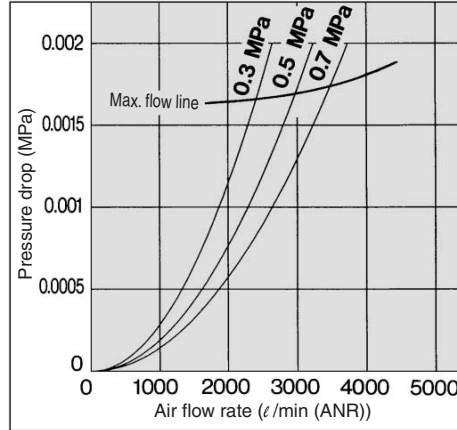

**AMG350**

3/8 B

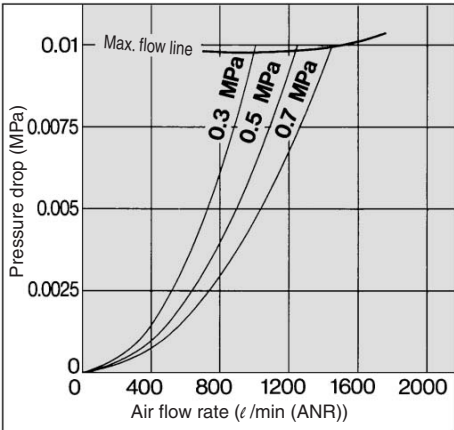

**AMG650**

1 B

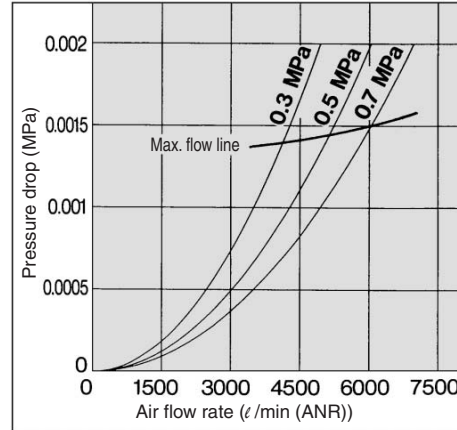

## Construction

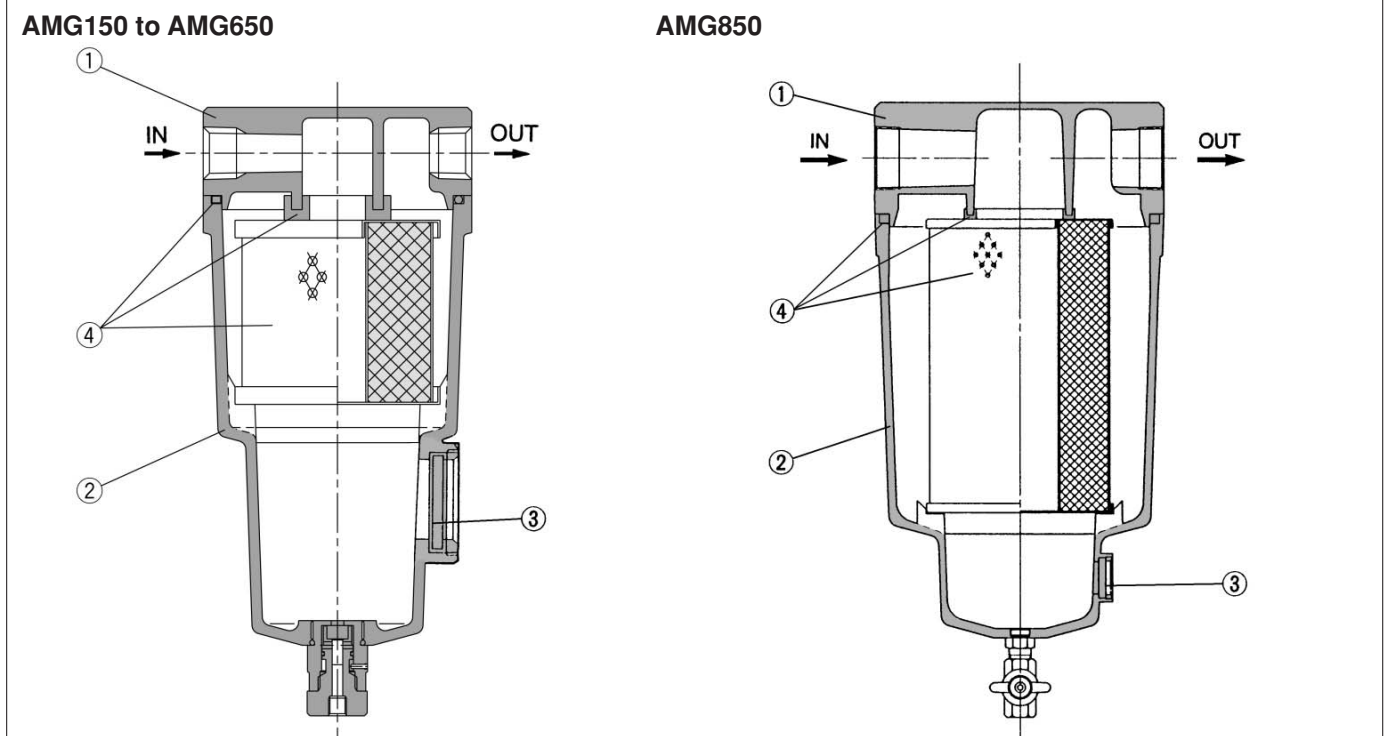

### Component Parts

No.	Description	Material	Note
①	Body	Aluminum die-casted	Chrome treated
②	Housing	Aluminum die-casted*	Epoxy coating on inner surface
③	Sight glass	Tempered glass	

\* AMG850 is aluminum casted.



Note) Refer to page 14-20-59 for "How to Order Bowl Assembly".



Note) Sight glass is indicated in the figure above for easy understanding of parts, however mounting position is different. Refer to dimensions on pages 14-20-6 to 7 for details.

### Replacement Parts

No.	Description	Material	Model						
			AMG150	AMG250	AMG350	AMG450	AMG550	AMG650	AMG850
④	Element assembly	Resin Others	AMG-EL150	AMG-EL250	AMG-EL350	AMG-EL450	AMG-EL550	AMG-EL650	AMG-EL850

\* Element assembly: With gasket and O-ring

### Max. Air Flow

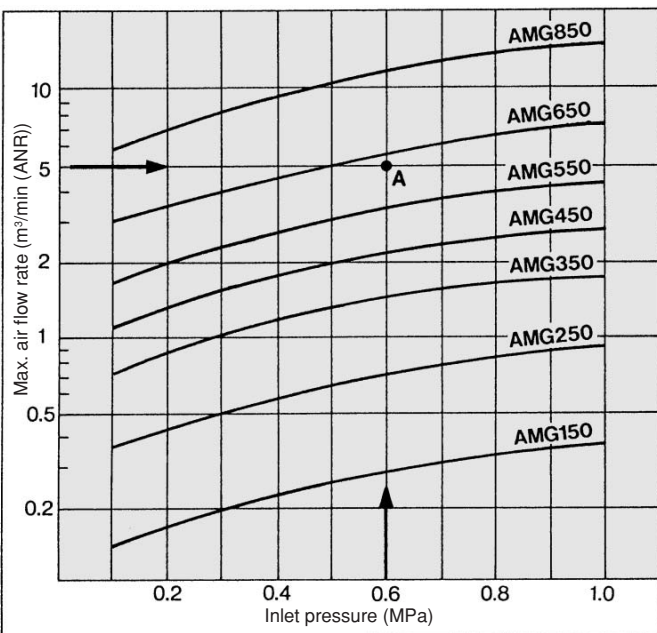

### Model Selection

Select the model in accordance with the following procedure taking the inlet pressure and max. air flow into consideration.

(Example) Inlet pressure: 0.6 MPa

Maximum air flow rate: 5 m<sup>3</sup>/min (ANR)

1. Select the point of contact A of inlet pressure and max. air capacity in the graph.
2. AMG650 is obtained when the max. flow line is above the point of intersection A in the graph.



Note) Make sure to select a model that has the maximum flow rate line above the obtained intersecting point. With a model that has the maximum flow rate line below the obtained intersecting point, the flow rate will be exceeded, thus leading to a problem such as being unable to satisfy the specifications.

HA

AT

ID

**AMG**

AFF

AM

Misc.

# Series AMG

## AMG150 to AMG650 Dimensions

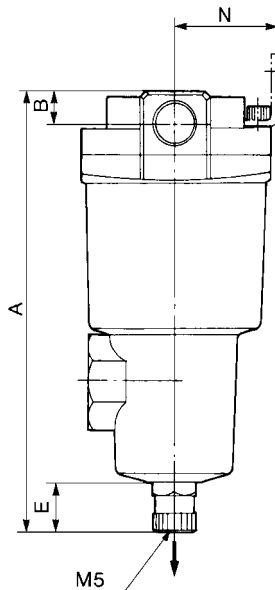
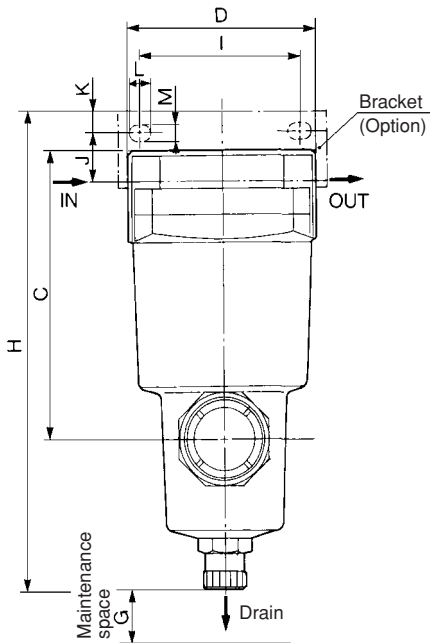
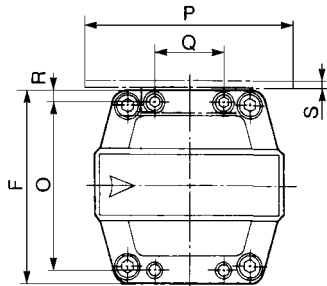

### Accessory

#### D: With auto-drain (N.O.)

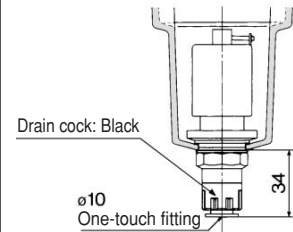

#### C: With auto-drain (N.C.)

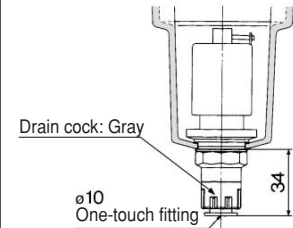

\* N.C. auto-drain not available for AMG650.

### Option

#### J: With drain guide

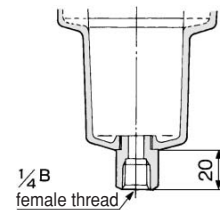

Model	Port size (Nominal size B)	A	B	C	D	E	F	G	Dimensions with mounting bracket											
									H	I	J	K	L	M	N	O	P	Q	R	S
AMG150	1/8, 1/4, 3/8	159	13	100	63	20	63	10	166	56	15	5	9	5.5	35	54	70	26	4.5	1.6
	1/4, 3/8	172	13	113	76	20	76	10	187	66	20	8	12	6	40	66	84	28	5	2.0
AMG250	1/2	178	16	119	76	20	76	10	187	66	17	8	12	6	40	66	84	28	5	2.0
	3/8, 1/2	204	16	145	90	20	90	10	218	80	22	8	14	7	50	80	100	34	5	2.3
AMG350	3/4	210	19	151	90	20	90	10	218	80	19	8	14	7	50	80	100	34	5	2.3
	1/2, 3/4	225	19	166	106	20	106	10	241	90	25	10	14	9	55	88	110	50	9	3.2
AMG450	1	232	22	173	106	20	106	10	241	90	21	10	14	9	55	88	110	50	9	3.2
	3/4, 1	259	22	200	122	20	122	10	277	100	30	10	16	9	65	102	130	60	10	4.5
AMG650	1, 1 1/2	311	32	253	160	20	160	10	334	150	40	15	20	11	85	136	180	76	12	4.5

## AMG850 Dimensions

### Accessory

D: With auto-drain (N.O. type) for AMG850

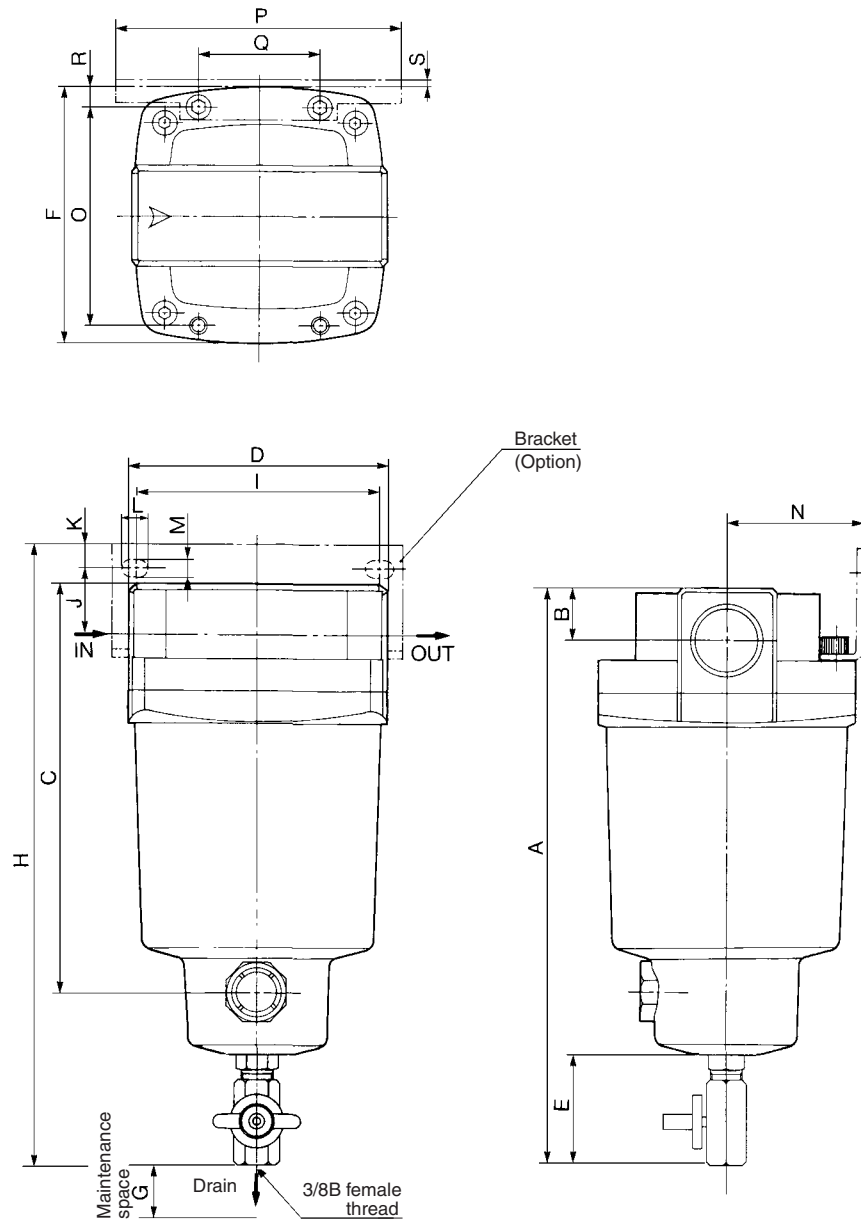
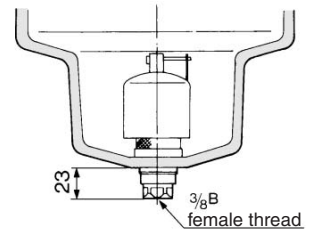

Model	Port size (Nominal size B)	A	B	C	D	E	F	G	Dimensions with mounting bracket											
									H	I	J	K	L	M	N	O	P	Q	R	S
AMG850	1/2, 2	460.5	42	348	220	57.5	220	10	463.5	180	30	15	24	13	120	184	220	110	18	6.0

HA

AT

ID

**AMG**

AFF

AM

Misc.