

e-Rodless Actuator



Operation Manual

E-MY2 Series



e-Actuator

SMC Corporation

URL <http://www.smcworld.com>

CONTENTS

Thank you for purchasing the SMC E-MY2 Series e-Rodless Actuator.
 Please read this manual carefully before operating the e-Rodless Actuator and make sure you understand the e-Rodless Actuator, its capabilities and limitations.
 Please keep this manual handy for future reference.

OPERATOR

- This operation manual has been written for those who have knowledge of machinery and apparatuses that use actuator and have full knowledge of assembly, operation and maintenance of such equipment.
- Please read this operation manual carefully and understand it before assembling, operating or providing maintenance service to the actuator.

Phone

AUSTRIA / (43) 2262-62 280
 BELGIUM / (32) 3-355 1464
 CZECH REP. / (420) 5-414 24611
 DENMARK / (45) 70 25 29 00
 FINLAND / (358) 9-859 580
 FRANCE / (33) 1-64 76 1000
 GERMANY / (49) 6103 4020
 GREECE / (30) 1- 342 6076
 HUNGARY / (36) 1-371 1343
 IRELAND / (353) 1-403 9000

ITALY / (39) 02-92711
 NETHERLANDS / (31) 20-531 8888
 NORWAY / (47) 67 12 90 20
 POLAND / (48) 22-548 50 85
 PORTUGAL / (351) 2 610 89 22
 SPAIN / (34) 945-18 4100
 SWEDEN / (46) 8-603 0700
 SWITZERLAND / (41) 52-396 3131
 TURKEY / (90) 212 221 1512
 UNITED KINGDOM / (44) 1908-56 3888

General	SAFETY	2
	Model Indication Method	5
	Names and Functions of Individual Parts	6
	Installation	9
3 positions	3 positions	
	Names and Functions of Controller	11
	Example of Internal Circuit and Wiring	12
	Setting	15
	Operation Characteristics	20
5 positions	Specifications	21
	5 positions	
	Names and Functions of Controller	23
	Example of Internal Circuit and Wiring	24
	Setting	27
General	Operation Characteristics	32
	Other Functions	33
	Specifications	34
	Common Functions	
General	Lock function	35
	Alarm indication and remedy	36
	Alarm reset	38

SAFETY

The e-Rodless Actuator and this manual contain essential information for the protection of users and others from possible injury and property damage and to ensure correct handling. Please check that you fully understand the definition of the following messages (signs) before going on to read the text, and always follow the instructions. Please read the operation manuals of related apparatus and understand it before operating the actuator.

IMPORTANT MESSAGES

Read this manual and follow its instructions. Signal words such as WARNING, CAUTION and NOTE, will be followed by important safety information that must be carefully reviewed.

⚠ WARNING

Indicates a potentially hazardous situation which could result in death or serious injury if you do not follow instructions.

⚠ CAUTION

Indicates a potentially hazardous situation which if not avoided, may result in minor injury or moderate injury.

NOTE

Gives you helpful information.

⚠ WARNING

Do not disassemble, remodel (including change of printed circuit board) or repair.

An injury or failure can result.

Do not perform operation and setting.

Electric shock may occur.

Do not operate beyond specification range.

Fire, malfunction or switch damage can result. Please use it after confirming the specification.

⚠ WARNING

Do not use the product in the environment with possible presence of flammable, explosive or corrosive gas with the product to prevent fire, explosion or corrosion.

Note the actuator doesn't have explosion proof construction.

During operation, do not enter your hand into moving range nor touch moving parts.

It may cause injury.

⚠ CAUTION

Do not touch the side and lower part of motor and controller.

These parts become hot and should not be touched until it is confirmed they become cool enough.

The grounding should be performed separately at short length near controller if possible.

Be sure to ground the product to keep the capability of resistance for the noise in the actuator. Ground with FG terminal.

Perform functional inspection after maintenance.

Stop operation when equipment or component doesn't work properly. Safety may not be guaranteed by unintended malfunction.

Ensure the safety in wiring for ALM signal by inputting emergency stop signal and causing successive error.

After the stroke is adjusted, turn on power supply and then perform stroke learning.

If the stroke learning is not performed, the product may not operate along with the adjusted stroke and damage the connected equipment.

Do not connect driving power supply and turn on it before the area where the work (slider) is moved confirms safety.

The movement of the work may cause accident. And when power supply is turned on, the work is returned to home position by input IN1 or IN2 signal. (Except that stroke learning is not performed at all.)

NOTE

Follow the instructions given below when handling your actuator. Otherwise, the switch may be damaged or may fail, thereby resulting in malfunction.

- Use at voltage over specified voltage.
- Do not apply the load over max.
- Keep the space for maintenance.
- Do not drop and collide the product or give excessive impact to it.
- Hold the body for handling.
- Keep tightening torque.
- Do not install the actuator to the place used as foot base for work.
- Keep flatness of mounting face for actuator within 0.1/500mm.
- Do not give repeated bending and tensile force to the connected cable to prevent the breakage of the cable.
- Connect wiring properly.
- Do not energize the product during wiring.
- Do not use in the place with dust, particle and splash of water, chemicals and oil to prevent breakage and malfunction of the product.
- Do not use in the place creating magnetic field to prevent the malfunction of the actuator.
- Do not use in the environment subject to temperature cycle.
- Do not use where close to surge generating source.
- Do not short the load. Short of the load of the controller is indicated as error, but it may cause over current and break the actuator.
- Do not push setting buttons with the pointed staff to avoid the damage of the buttons.
- Perform maintenance for the product periodically.

Model Indication Method

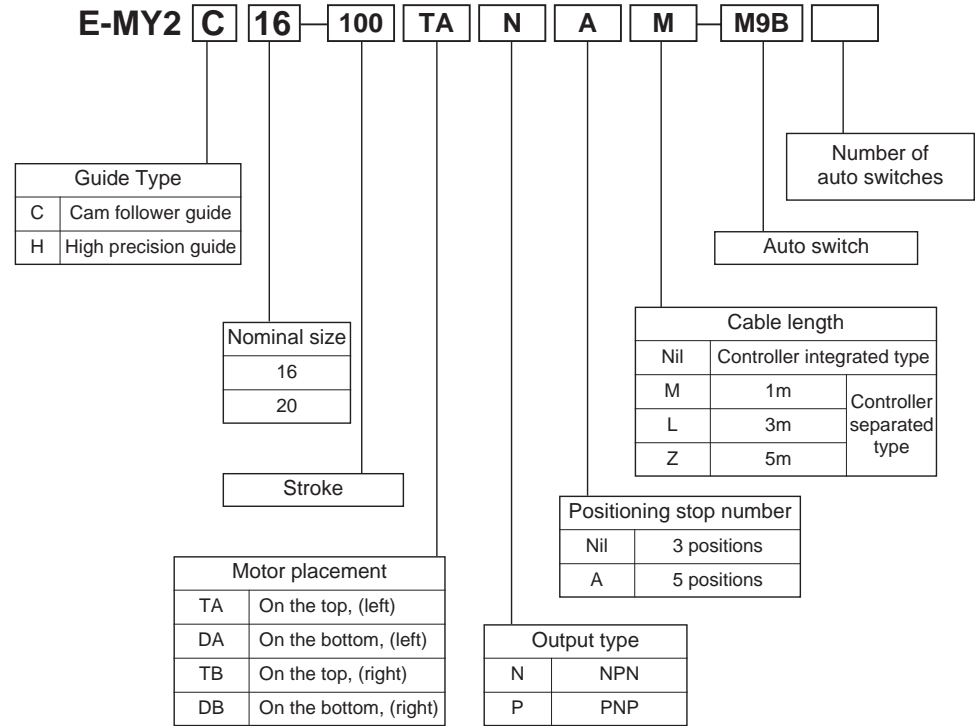

Note) Refer to the catalog for Stroke, Auto switch and Number of auto switches.

Options

- Controller mount bracket
- L type bracket ***** MYE-LB Hexagon socket head screw M5 x 8 (2)
- DIN rail bracket ***** MYE-DB Cross recessed panhead screw M3 x 6.5 (2)
Clamp screw M4 x 10 (1)

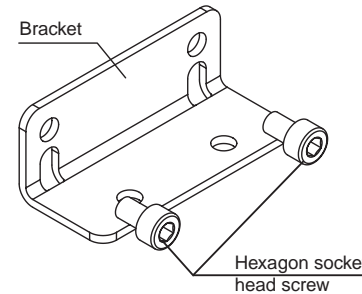

L type bracket (MYE-LB)

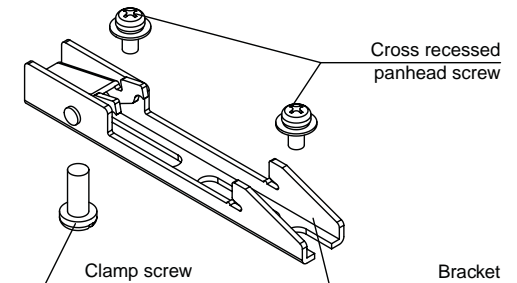

DIN rail bracket (MYE-DB)

Names and Functions of Individual Parts

Controller integrated type

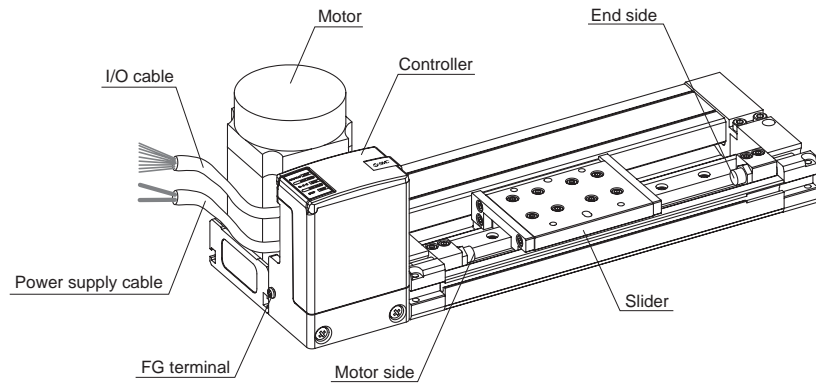

Controller separated type

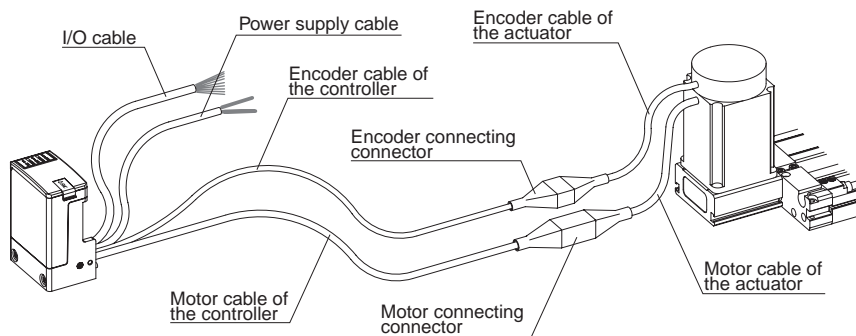

Description	Content/Function
Slider	The parts which can move in the actuator
Motor	The motor to move the actuator
Power supply cable	The power supply line to drive the actuator
I/O cable	The signal line to transmit signal of positioning completion and command for drive
Controller	The unit to control, set and indicate the actuator
FG terminal	The terminal to connect FG cable
Encoder cable of the actuator	Encoder cable connecting the actuator and the controller
Motor cable of the actuator	Motor cable connecting the actuator and the controller
Encoder cable of the controller	Encoder cable to separate the controller
Motor cable of the controller	Motor cable to separate the controller

Installation

Read "Precautions for Handling" of safety instruction and "How to install" of this chapter with care to provide safe and exact measurement for installation of the actuator.

Installation of body

Use 4 mounting holes on the top of the body or nuts inside 2 T slots on the bottom of the body for installation.

Front view

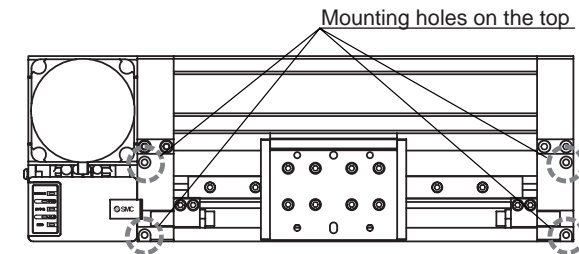

Bottom view

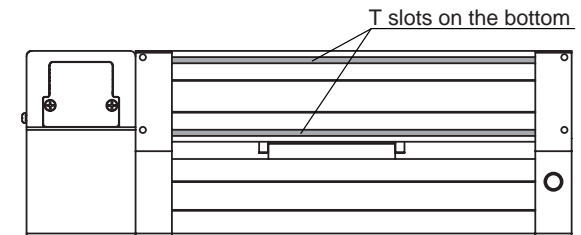

Mounting holes on the top

Nominal of actuator	Thread size
16	M3
25	M5

T slots on the bottom

Nominal of actuator	Thread size	Effective length
16	M3	4 to 5mm
25	M5	6 to 8mm

•If T slots on the bottom is used for installation, select screw which enables only effective length of it to enter from the bottom.

General
3 positions
5 positions
General

General
3 positions
5 positions
General

Installation of work

Use 4 taps on the top of slider for installation of work.
Also, if necessary, utilize knock pin hole as well.

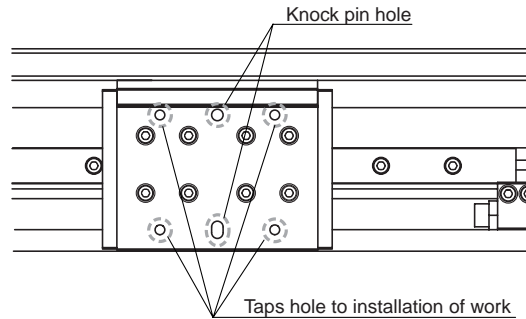

Installation of work tap

Nominal of actuator	Threaded hole dimension	Effective length
16	M4 depth 7mm	4 to 7mm
25	M5 depth 9mm	5 to 9mm

•Select screw which enables effective length of thread to enter.

Knock pin hole

Nominal of actuator	Hole diameter and width of oval hole
16	(φ)4 H7 depth 5mm
25	(φ)5 H7 depth 5mm

Precautions for installation

- Do not operate the actuator outside operating temperature range.
 - Do not install the actuator in the place which may be used as foot base.
 - Keep flatness following mechanical accuracy or equivalent reference for the face where the actuator is installed.
- Also, confirm the flatness is within 0.1/500mm

Mounting controller (When controller separated type is used)

How to remove controller

Loosen M4 mounting screw shown in fig. 1 and remove the controller.

Direct mounting

Use M4 mounting screw shown in fig. 1 or M5 tap hole to mount the controller.

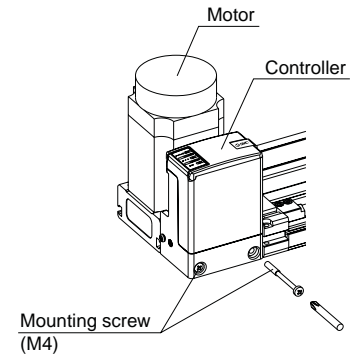

fig. 1

Mounting by L type bracket

Mount the optional L type bracket on the main unit using the two mounting screws M5X8L and install on the facility using hexagon socket head cap screws as shown in fig. 2.

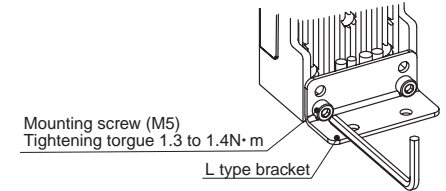

fig. 2

Mounting by DIN rail bracket

Use set screw to mount optional DIN rail mount bracket to the body.
When mounting, lower the clamp bracket as in fig. 3.
Please be noted that some tools may interfere with clamp bracket.

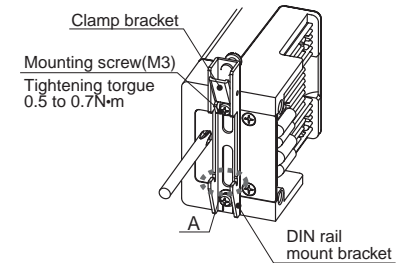

fig. 3

When setting to DIN rail, place A of fig. 3 into DIN rail.
While pushing it, fix it by the clamp of screw in fig. 4.
Inadequate pushing may cause falling of parts.

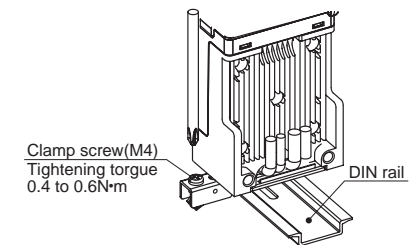
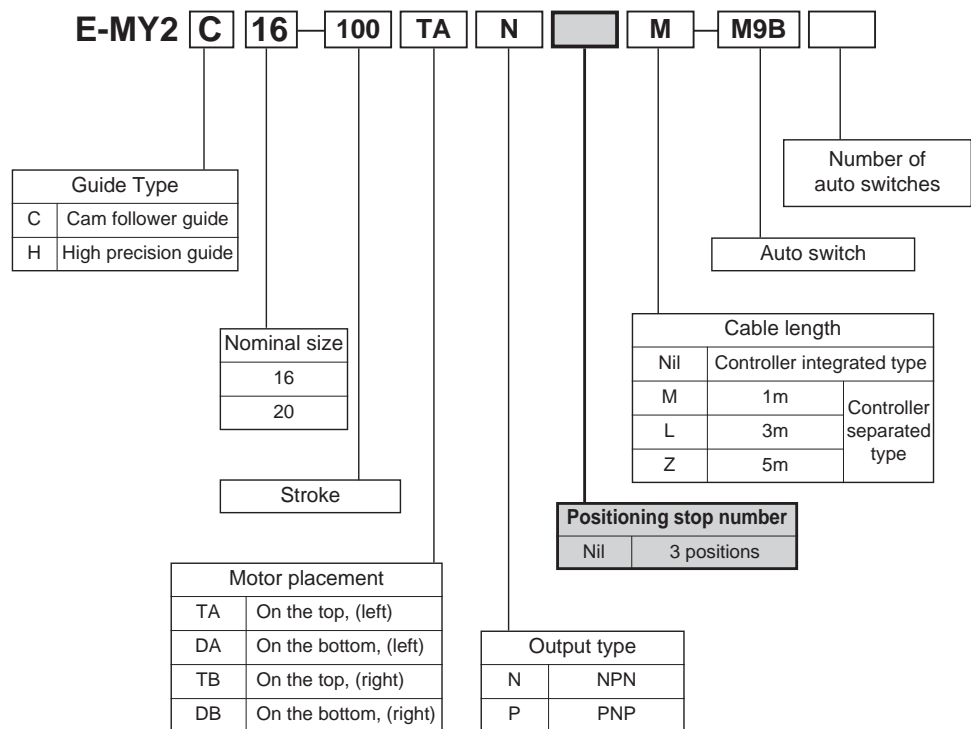

fig. 4

3 positions



Note) Refer to the catalog for Stroke, Auto switch and Number of auto switches.

3 positions

Names and Functions of Controller	11
Example of Internal Circuit and Wiring	12
Setting	15
Operation Characteristics	20
Specifications	21

Names and Functions of Controller (3 positions)

Controller detail

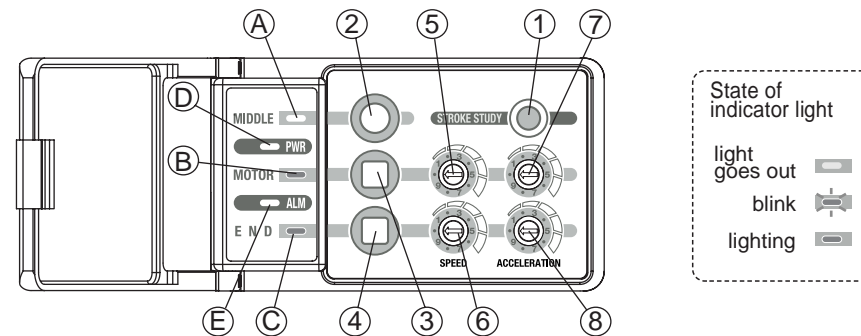

Switch

No.	Content/Function
①	Stroke learning switch
②	The switch to move the actuator to intermediate position and set the intermediate position
③	The switch to move the work to motor end
④	The switch to move the work to the other end
⑤	The rotary switch to set moving speed to motor end
⑥	The rotary switch to set moving speed to the other end
⑦	The rotary switch to set moving acceleration to motor end
⑧	The rotary switch to set moving acceleration to the other end

Display of the indicator lamp and basic operation

Symbol	Description	Power is turn on	When positioning completed			In case of error
			Motor side	End side	Intermediate	
Ⓐ	MIDDLE indicator lamp(Green)	—	—	—	○	※ 1
Ⓑ	MOTOR indicator lamp(Green)	—	○	—	—	
Ⓒ	END indicator lamp(Green)	—	—	○	—	
Ⓓ	PWR indicator lamp(Green)	○	○	○	○	○
Ⓔ	ALM indicator lamp(Red)	—	—	—	—	○

"○" indicates light is on, "—" indicates light is off.

※ 1 See page 36, 37 and after for ALM display in case of error.

Example of Internal Circuit and Wiring

● Electric Specification

Item	Specification	
Power supply for drive	Power supply voltage	DC24V ± 10%
	Current consumption	Max.5A(within 2s) normally 2.5A at DC24V
Power supply for signal	Power supply voltage	DC24V ± 10%
	Current consumption	30mA + output load capacity at DC24V
Input signal capacity	6mA or less / 1 circuit at DC24V(Photo-coupler input)	
Output load capacity	DC30V or less, 20mA or less / 1 circuit(opendrain output)	
Abnormal detection items	Emergency stop, Abnormal external output, Abnormal power supply, Abnormal drive, Abnormal temperature, Abnormal stroke, Abnormality of motor, Abnormality of controller	

Power supply cable 2 wire AWG20(20 wire/0.16mm²)

Symbol	Cable color	Signal name	Content
DC1(+)	Brown	Vcc	Power supply cable for actuator operation
DC1(-)	Blue	GND	

I/O cable 9 wire AWG28(7 wire/0.127mm²)

Symbol	Cable color	Signal name	Content
DC2(+)	Brown	Vcc	Power supply line for signal
DC2(-)	Blue	GND	
OUT1	Pink	READY output	The signal to show the controller can be operated
OUT2	Orange	The output for completion of positioning 1	The signal to show the positioning is completed
OUT3	Yellow	The output for completion of positioning 2	
OUT4	Green	Alarm output	The signal to show the alarm occurs
IN1	Purple	The input transmit drive command 1	The signal to transmit drive command
IN2	Grey	The input transmit drive command 2	
IN3	White	Emergency stop input	The signal to transmit emergency stop command(When contact is opened)

•The product can be used without connection of I/O cable, but in that case, consider the safety and install power supply switch for drive. And for emergency case, turn off the switch.

•Corresponding to NPN I/O

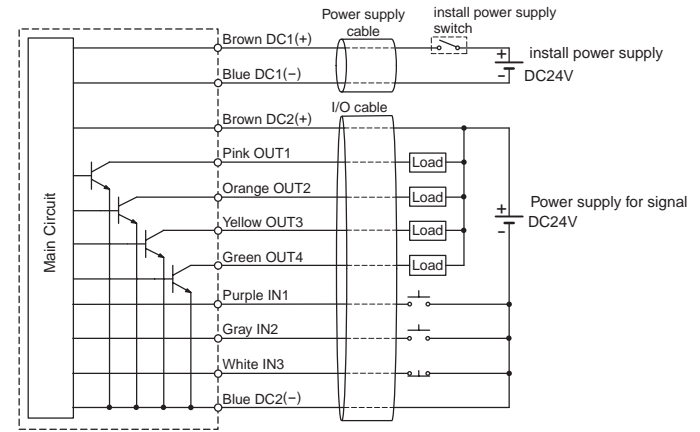

•Corresponding to PNP I/O

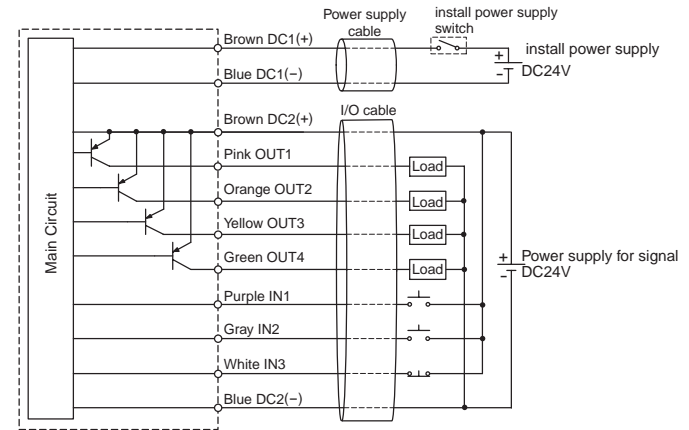

Signal through I/O cable

Input signal

Command	Symbol	
	IN1	IN2
Command to operate motor side	○	—
Command to operate end side	—	○
Command to operate intermediate stop	○	○

○ means ON, — means OFF

Output signal

Actuator condition	Symbol		
	OUT1	OUT2	OUT3
When motor side positioning completed	○	○	—
When end side positioning completed	○	—	○
When Intermediate stop positioning completed	○	○	○
During actuating	—	—	—

○ means ON, — means OFF

**Connection of the motor and the controller
(When controller separated type is used)**

CAUTION

Do not pull the cable forcefully when removing attaching / detaching the connector.
Cable might be disconnected.

Turn off the power during connecting.
The slider may run suddenly.

- Mind the direction of the connector and insert them until they click when connecting the cable.
- When pulling out the cable, pull them out while pressing connector lever.

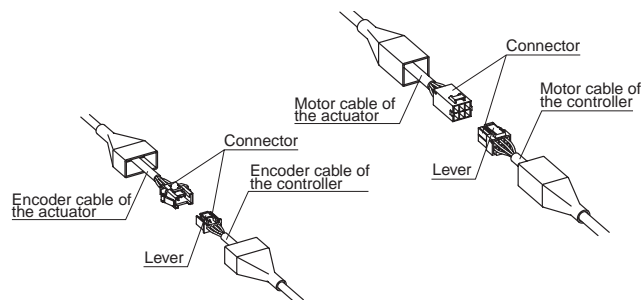

Setting

Setting Procedures

Confirm the product is installed and connected properly and perform setting in the following procedure.

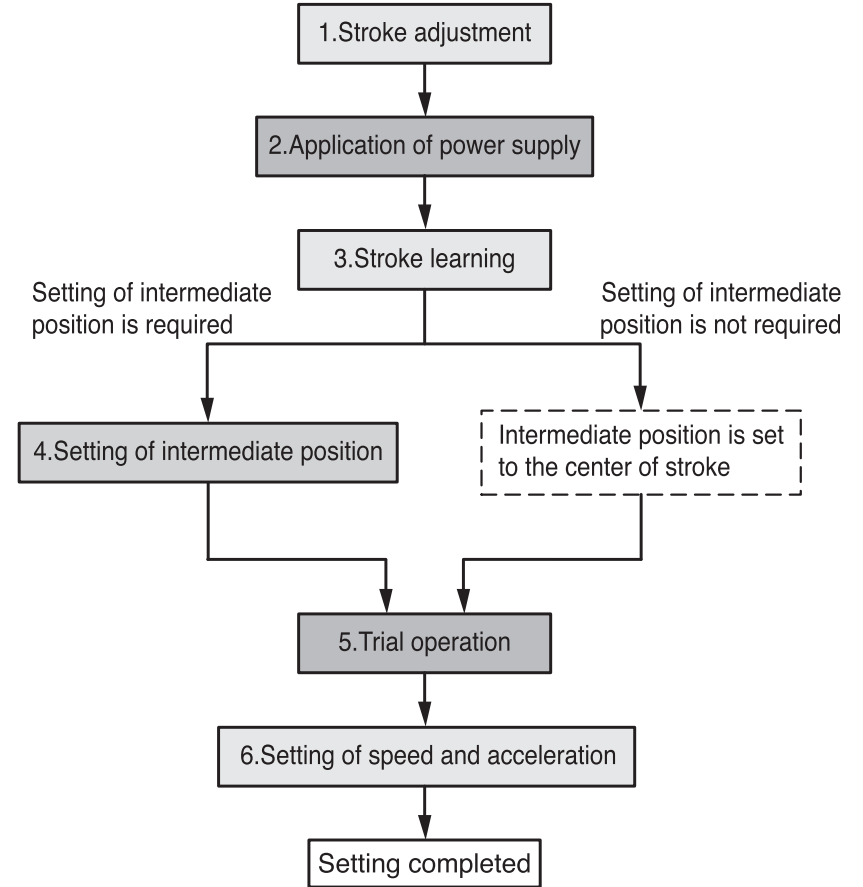

1. Stroke adjustment

Adjust the stroke of actuating part.

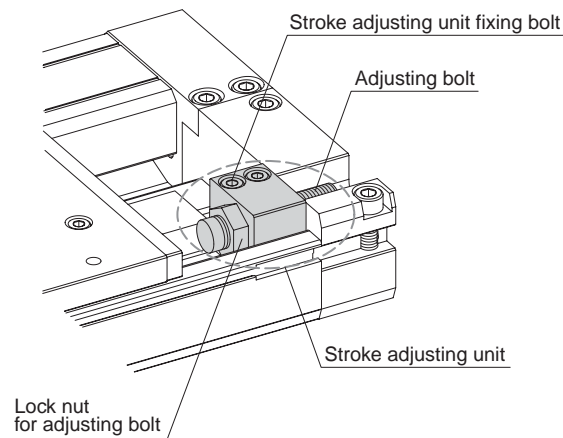

- 1-1 Loosen stroke adjusting unit fixing bolt, move the unit to the position where required stroke is obtained and fix the unit by the bolt.
- 1-2 Loosen lock nut for adjusting bolt for fine setting of stroke by the bolt. After the fine adjustment, tighten the lock nut again to fix the stroke.

2. Application of power supply

Apply DC24V to power supply for signal and drive.

CAUTION

After the stroke is adjusted, turn on power supply and then perform stroke learning.

If the stroke learning is not performed, the product may not operate along with the adjusted stroke and damage the connected equipment.

If leaning of stroke is not completed, 3 indicator lamps, MOTOR, END and MIDDLE light on. If the stroke learning is completed, with receipt of drive command, the product starts return to original position (movement to motor side or end side).

- Intermediate stop command does not perform return to origin.
- If necessary, re-application of power supply should be done when 5s or more passes after PWR indicator lamp goes off.

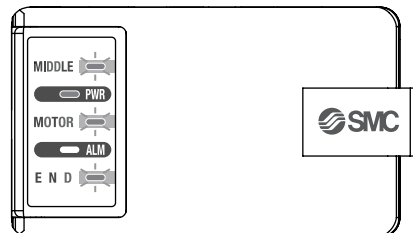

3. Stroke learning

3-1 By push of ① over 3s at least, the product comes into learning mode and starts stroke learning.

3-2 Confirm 2 indicator lamps MOTOR and END are lighting.

Since the actuator starts moving automatically to learn the adjusted stroke, do not put any objection such as tool and work around the actuator. 3-3 After stroke learning is completed, the actuator stops at motor side and MOTOR indicator lamp lights on.

- It is noted to put neither the tool nor work, etc. on surroundings of the actuator.

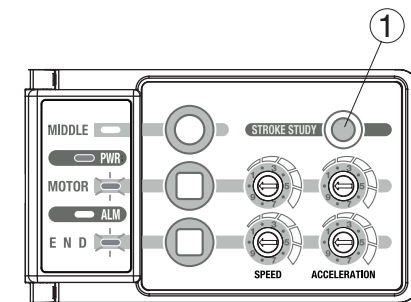

4. Setting of intermediate position

WARNING

During operation, do not enter your hand into moving range nor touch moving parts. It may cause injury.

4-1 Slider is moved to the specified intermediate position with following method.

When intermediate position is not set, position 1 to 3 are all set at the center of the stroke.

Note) After pressing ②, the indicator lamp of MIDDLE, MOTOR, and END blink for max. 3s.

4-2 By push of ② over 1s at least again during lighting of MIDDLE indicator lamp (See page 8 for indicator lamp of intermediate 1 to 3), setting mode for intermediate position is achieved.

4-3 Confirm the MIDDLE indicator lamp is flashing.

4-4 Select setting method between direct teaching setting and JOG teaching setting. Initially, intermediate position is set to the point on half of adjusted stroke.

4-4-1 Direct teaching setting Move slider manually during setting.

4-4-2 JOG teaching setting Move slider by push of ③ or ④ of controller during setting.

4-5 After the intermediate position is fixed, push ② over 1s to return the actuator to normal operation.

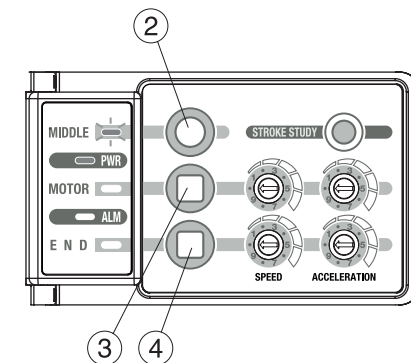

5. Trial operation

Push ②, ③ and ④ to check the operation adjusted in the above processes. (See operation method of 4-1 for the travel to intermediate stop)

Precautions on intermediate position

Intermediate position is set relative to the motor side.

Therefore, if the stroke adjusting unit at the motor side is moved, the intermediate position is changed.

On the other hand, change of the position of the stroke adjusting unit at stroke does not make sense.

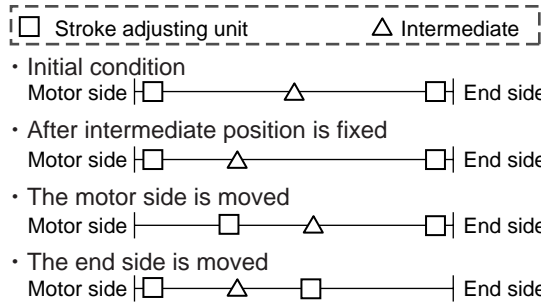

If the stroke is set shorter than the distance between the motor side and intermediate position, the intermediate position is fixed to the center of the stroke automatically.

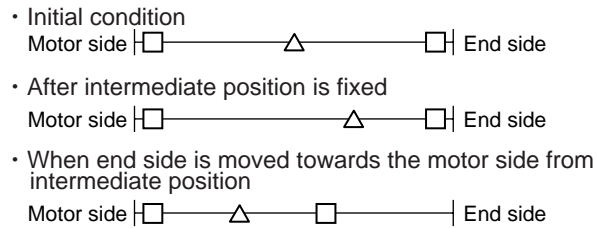

6. Setting of speed and acceleration

6-1 Setting of speed

By adjustment of switch ⑤ and ⑥, the speed of actuator is set.

⑤: Rotary switch to set speed of movement to the direction of the motor side.

⑥: Rotary switch to set speed of movement to the direction of the end side.

6-2 Setting of acceleration

By adjustment of switch ⑦ and ⑧, the acceleration of actuator is set.

⑦: Rotary switch to set acceleration of movement to the direction of the motor side.

⑧: Rotary switch to set acceleration of movement to the direction of the end side.

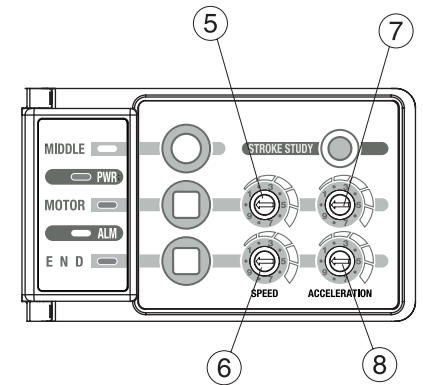
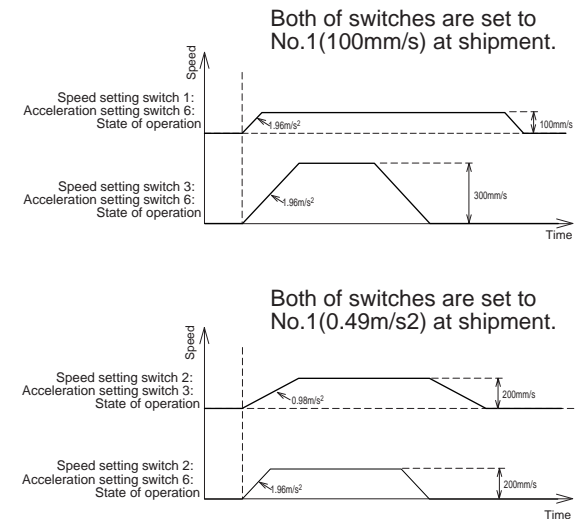

Figure.

Switch and speed, acceleration

Switch No.	Speed [mm/s]	Acceleration [mm/s ²]
1	100	0.49
2	200	0.74
3	300	0.98
4	400	1.23
5	500	1.47
6	600	1.96
7	700	2.45
8	800	2.94
9	900	3.92
10	1000	4.90

All switch No. of ex-factory is set at 1 (speed: 100mm/s, acceleration 0.49m/s²).



Operation Characteristics

Application of power supply

When power supply is applied, the controller is initialized and then READY output is performed.

If first transit of used power supply is 1s or more, the alarm output is performed in prior to initialization and READY output.

If emergency stop input is released, READY output is not sent and alarm output is generated instead.

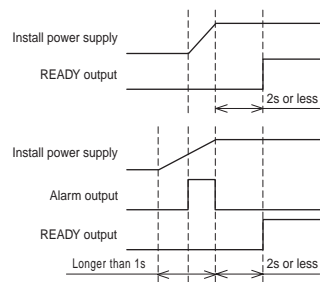

Movement to end

Ex.) Movement from motor side to end side

Do not turn off input of drive command until READY output is confirmed.

The signal for completion of positioning is output when the actuator reaches the position 0.5mm before target position (indicated as A).

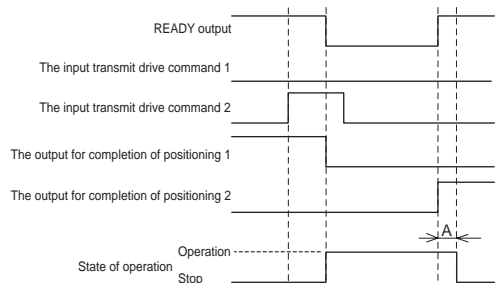

Intermediate operation

Ex.) Movement from motor side to intermediate position

Only if drive command 1 and 2 are input within 5 msec, the intermediate operation is performed. Input over 5 msec moves the actuator to motor end or the other end.

The signal for completion of positioning is output when the actuator reaches the position 0.5mm before target position (indicated as A).

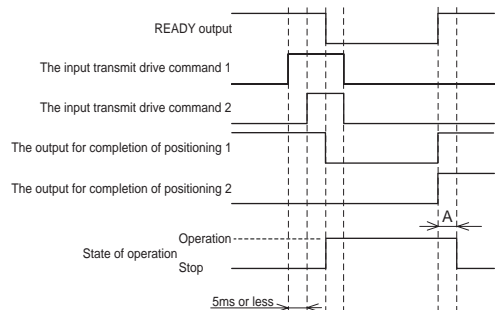

Specifications

Standard specifications

Item		Specification	
Model	E-MY2 ※		
Nominal size	16	25	
Maximum load weight ^(NOTE)	5kg	10kg	
Transfer speed set range	100 to 1000 mm/s		
Transfer speed acceleration set range	0.49 to 4.90 m/s ²		
Acceleration and deceleration method	Trapezoidal drive		
Moving direction	Horizontal direction		
Positioning points	Both ends (mechanical stoppers), 1 intermediate position		
Repeated Positioning stopping precision	Both ends	±0.01mm	
	Intermediate stopping position	±0.1mm	
Intermediate stopping point positioning method	Direct teaching, JOG teaching		
Positioning setting spot	Controller body		
Display	LED for power supply, LED for alarming, LED for positioning completion		
Input signal	Actuation command signal, Emergency stop input signal		
Output signal	Positioning completion signal, Emergency detection signal, Ready signal		

NOTE) The maximum load weight shows the motor ability.

Please consider it together with the guide load factor when selecting a model.

Electric Specification

Item		Specification
Power supply for drive	Power supply voltage	DC24V ± 10%
	Current consumption	Max.5A(within 2s) normally 2.5A at DC24V
Power supply for signal	Power supply voltage	DC24V ± 10%
	Current consumption	30mA + output load capacity at DC24V
Input signal capacity		6mA or less / 1 circuit at DC24V(Photo-coupler input)
Output load capacity		DC30V or less, 20mA or less / 1 circuit(opendrain output)
Abnormal detection items		Emergency stop, Abnormal external output, Abnormal power supply, Abnormal drive, Abnormal temperature, Abnormal stroke, Abnormality of motor, Abnormality of controller

Environment specifications

Item		Specification
Operating temperature range	Actuator	5 to 50 °C
	Controller (separated type)	5 to 40 °C
Operating humidity range		35 to 85%RH (with no condensation)
Storage temperature range		-10 to 60 °C (with no condensation and freezing)
Storage humidity range		35 to 85%RH (no condensation)
Withstand voltage		Between all of external terminals and the case: 1000 VAC for 1 minute
Insulation resistance		Between external terminal and case: 50 MΩ (500 VDC)
Noise resistance		1000 Vp-p Pulse width 1 μs, Rise time 1 ns
Acquired certified standard		CE marking

5 positions

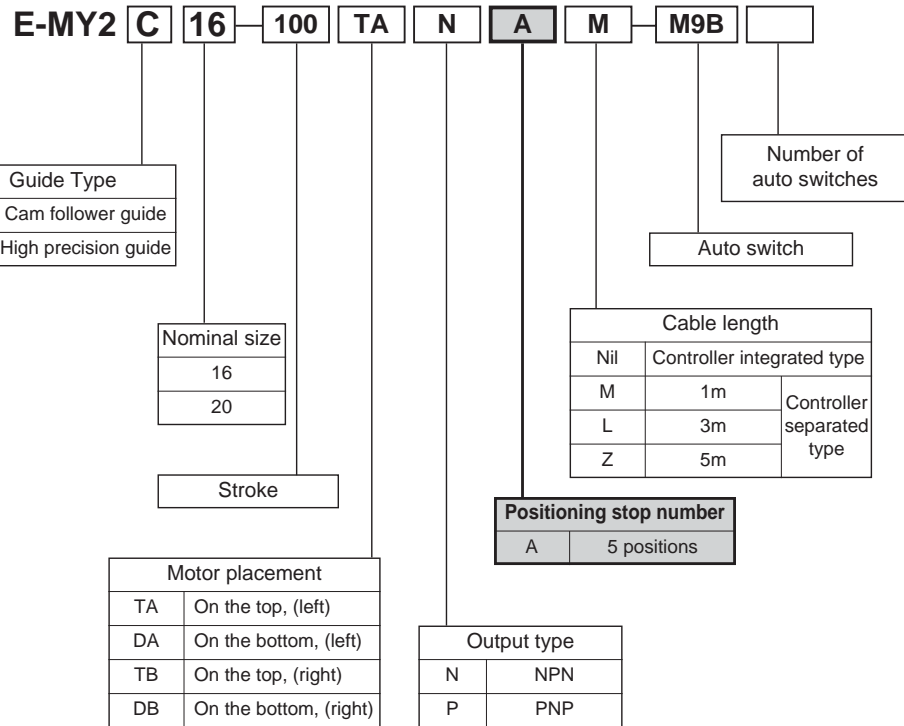

Note) Refer to the catalog for Stroke, Auto switch and Number of auto switches.

5 positions

Names and Functions of Controller	23
Example of Internal Circuit and Wiring	24
Setting	27
Operation Characteristics	32
Other Functions	33
Specifications	34

Names and Functions of Controller (5 positions)

Controller detail

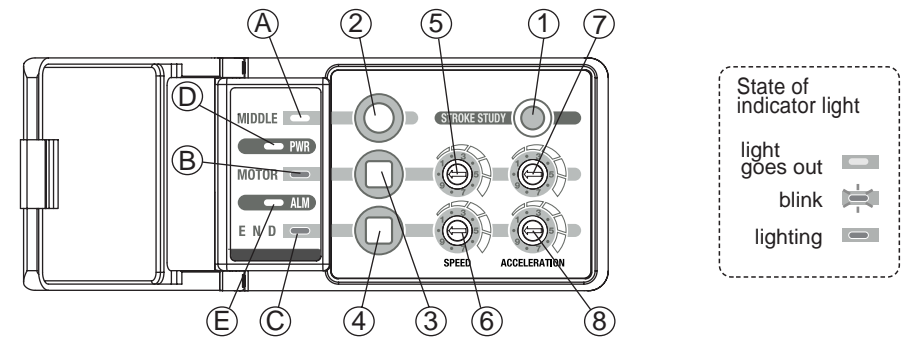

Switch

No.	Content/Function
①	Stroke learning switch
②~④ ※ 1	Switch to move slider part and intermediate position set switch
⑤	Rotary switch to set speed of movement to the direction of the motor side
⑥	Rotary switch to set speed of movement to the direction of the end side
⑦	Rotary switch to set acceleration of movement to the direction of the motor side
⑧	Rotary switch to set acceleration of movement to the direction of the end side

※ 1 See Page 30 Operation method for moving method.

Display of the indicator lamp and basic operation

Symbol	Description	Power is turn on	When positioning completed					External input stop completed	In case of alarm
			Motor side	End side	Intermediate 1	Intermediate 2	Intermediate 3		
Ⓐ	MIDDLE indicator lamp(Green)	—	—	—	○	○	○	—	※ 2
Ⓑ	MOTOR indicator lamp(Green)	—	○	—	—	○	—	○	
Ⓒ	END indicator lamp(Green)	—	—	○	—	—	○	○	
Ⓓ	PWR indicator lamp(Green)	○	○	○	○	○	○	○	○
Ⓔ	ALM indicator lamp(Red)	—	—	—	—	—	—	—	○

"○" indicates light is on, "—" indicates light is off.

※ 2 See page 36, 37 and after for ALM display in case of error.

Example of Internal Circuit and Wiring

● Electric Specification

Item	Specification	
Power supply for drive	Power supply voltage	DC24V ± 10%
	Current consumption	Max.5A(within 2s) normally 2.5A at DC24V
Power supply for signal	Power supply voltage	DC24V ± 10%
	Current consumption	30mA + output load capacity at DC24V
Input signal capacity	6mA or less / 1 circuit at DC24V(Photo-coupler input)	
Output load capacity	DC30V or less, 20mA or less / 1 circuit(opendrain output)	
Abnormal detection items	Emergency stop, Abnormal external output, Abnormal power supply, Abnormal drive, Abnormal temperature, Abnormal stroke, Abnormality of motor, Abnormality of controller	

Power supply cable 2 wire AWG20(20 wire/0.16mm²)

Symbol	Cable color	Signal name	Content
DC1(+)	Brown	Vcc	Power supply cable for actuator operation
DC1(-)	Blue	GND	

I/O cable 11 wire AWG28(7 wire/0.127mm²)

Symbol	Cable color	Signal name	Content
DC2(+)	Brown	Vcc	Power supply line for signal
DC2(-)	Blue	GND	
OUT1	Pink	READY output	The signal to show the controller can be operated
OUT2	Orange	The output for completion of positioning 1	The signal to show the positioning is completed
OUT3	Yellow	The output for completion of positioning 2	
OUT4	Red	The output for completion of positioning 3	The signal to show the alarm occurs
OUT5	Green	Alarm output	
IN1	Purple	The input transmit drive command 1	The signal to transmit drive command
IN2	Grey	The input transmit drive command 2	
IN3	Black	The input transmit drive command 3	
IN4	White	Emergency stop input	The signal to transmit emergency stop command(When contact is opened)

•The product can be used without connection of I/O cable, but in that case, consider the safety and install power supply switch for drive. And for emergency case, turn off the switch.

•Corresponding to NPN I/O

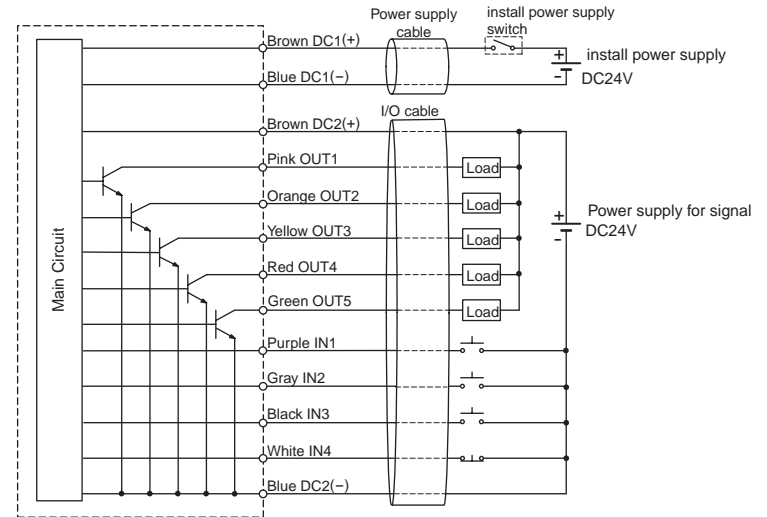

•Corresponding to PNP I/O

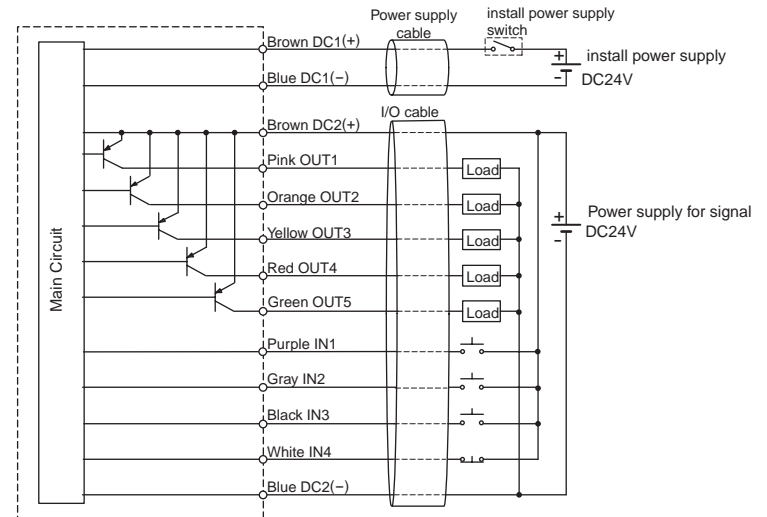

Example of Internal Circuit and Wiring (continue)

Signal through I/O cable

Input signal

Command	Symbol		
	IN1	IN2	IN3
Command to operate motor side	○	—	—
Command to operate end side	—	○	—
Command to operate intermediate stop 1	—	—	○
Command to operate intermediate stop 2	○	—	○
Command to operate intermediate stop 3	—	○	○
External input stop command	○	○	—

○ means ON, — means OFF

Output signal

Actuator condition	Symbol			
	OUT1	OUT2	OUT3	OUT4
External controll allowed	○	—	—	—
When motor side positioning completed	○	○	—	—
When end side positioning completed	○	—	○	—
When Intermediate stop 1 positioning completed	○	—	—	○
When Intermediate stop 2 positioning completed	○	○	—	○
When Intermediate stop 3 positioning completed	○	—	○	○
External input stop operation is completed	○	○	○	—

○ means ON, — means OFF

Connection of the motor and the controller (When controller separated type is used)

⚠ CAUTION

Do not pull the cable forcefully when removing attaching / detaching the connector.

Cable might be disconnected.

Turn off the power during connecting.
The slider may run suddenly.

- Mind the direction of the connector and insert them until they click when connecting the cable.
- When pulling out the cable, pull them out while pressing connector lever.

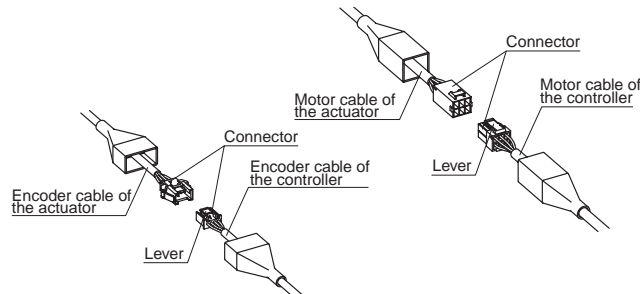

Setting

Setting Procedures

Confirm the product is installed and connected properly and perform setting in the following procedure.

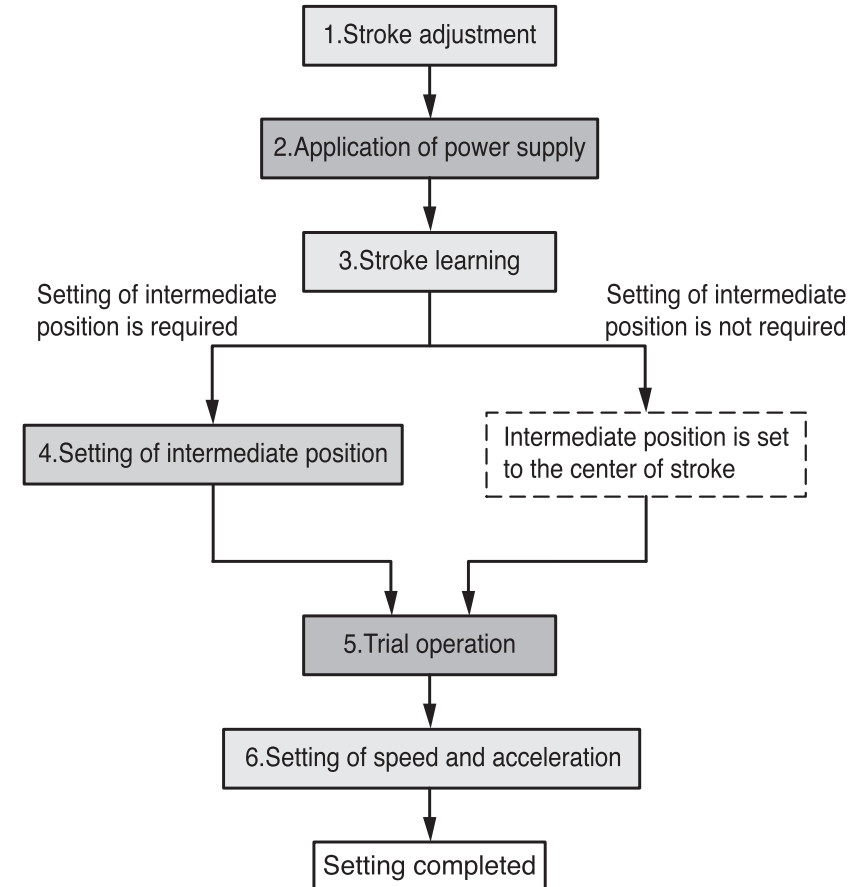

1. Stroke adjustment

Adjust the stroke of actuating part.

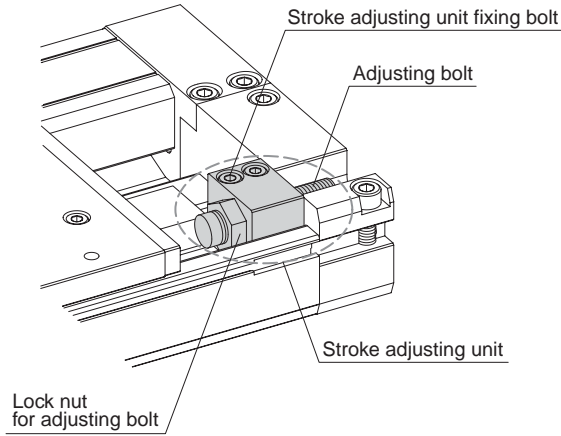

- 1-2 Loosen stroke adjusting unit fixing bolt, move the unit to the position where required stroke is obtained and fix the unit by the bolt.
- 1-2 Loosen lock nut for adjusting bolt for fine setting of stroke by the bolt. After the fine adjustment, tighten the lock nut again to fix the stroke.

2. Application of power supply

Apply DC24V to power supply for signal and drive.

CAUTION

After the stroke is adjusted, turn on power supply and then perform stroke learning.

If the stroke learning is not performed, the product may not operate along with the adjusted stroke and damage the connected equipment.

If leaning of stroke is not completed, 3 indicator lamps, MOTOR, END and MIDDLE light on. If the stroke learning is completed, with receipt of drive command, the product starts return to original position (movement to motor side or end side).

- Intermediate stop command does not perform return to origin.
- If necessary, re-application of power supply should be done when 5s or more passes after PWR indicator lamp goes off.

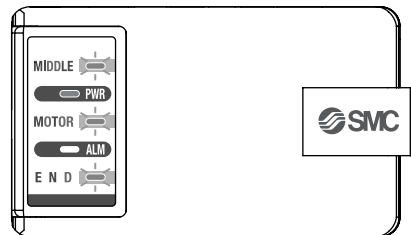

3. Stroke learning

3-1 By push of ① over 3s at least, the product comes into learning mode and starts stroke learning.

3-2 Confirm 2 indicator lamps MOTOR and END are lighting.

Since the actuator starts moving automatically to learn the adjusted stroke, do not put any objection such as tool and work around the actuator. 3-3 After stroke learning is completed, the actuator stops at motor side and MOTOR indicator lamp lights on.

- It is noted to put neither the tool nor work, etc. on surroundings of the actuator.

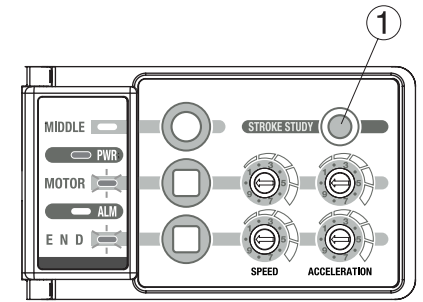

4. Setting of intermediate position

WARNING

During operation, do not enter your hand into moving range nor touch moving parts. It may cause injury.

4-1 Slider is moved to the specified intermediate position with following method.

● Operation method

Travel to intermediate position 1	Press ② again within 3s after pressing ②.
Travel to intermediate position 2	Press ③ within 3s. after pressing ②.
Travel to intermediate position 3	Press ④ within 3s. after pressing ②.

Note) After pressing ②, the indicator lamp of MIDDLE, MOTOR, and END blink for max. 3s. When intermediate position is not set, position 1 to 3 are all set at the center of the stroke.

- 4-2 By push of ② over 1s at least again during lighting of MIDDLE indicator lamp (See page 22 for indicator lamp of intermediate 1 to 3), setting mode for intermediate position is achieved.
- 4-3 Confirm the MIDDLE indicator lamp is flashing.
- 4-4 Select setting method between direct teaching setting and JOG teaching setting. Initially, intermediate position is set to the point on half of adjusted stroke.

- 4-4-1 Direct teaching setting
Move slider manually during setting.
- 4-4-2 JOG teaching setting
Move slider by push of ③ or ④ of controller during setting.

4-5 After the intermediate position is fixed, push ② over 1s to return the actuator to normal operation.

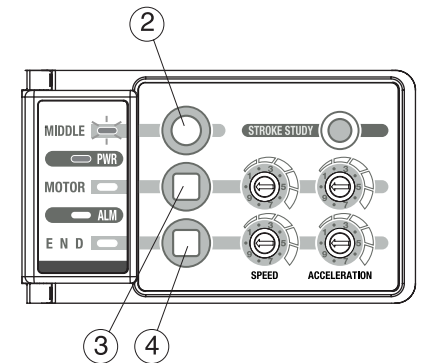

Precautions on intermediate position

Intermediate position is set relative to the motor side.

Therefore, if the stroke adjusting unit at the motor side is moved, the intermediate position is changed.

On the other hand, change of the position of the stroke adjusting unit at stroke does not make sense.

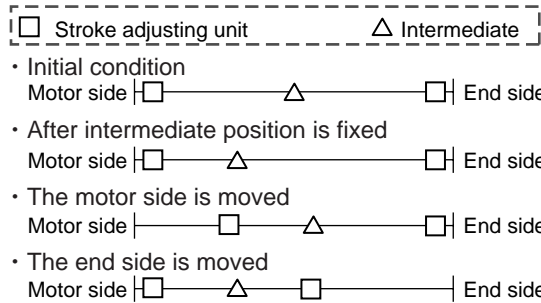

If the stroke is set shorter than the distance between the motor side and intermediate position, the intermediate position is fixed to the center of the stroke automatically.

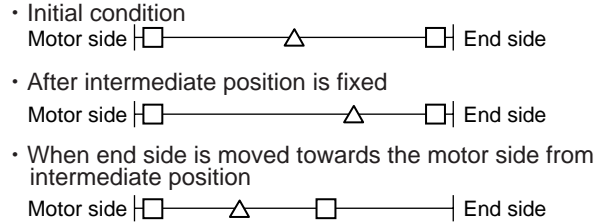

5.Trial operation

Push ②, ③ and ④ to check the operation adjusted in the above processes.

● Operation method

Travel to Motor side	Press ③ .
Travel to End side	Press ④ .
Travel to intermediate position 1	Press ② again within 3s after pressing ②.
Travel to intermediate position 2	Press ③ again within 3s after pressing ②.
Travel to intermediate position 3	Press ④ again within 3s after pressing ②.

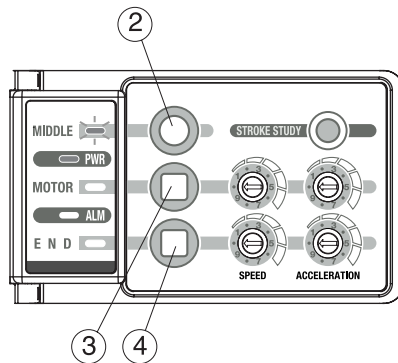

6.Setting of speed and acceleration

6-1 Setting of speed

By adjustment of switch ⑤ and ⑥, the speed of actuator is set.

⑤ :Rotary switch to set speed of movement to the direction of the motor side.

⑥ :Rotary switch to set speed of movement to the direction of the end side.

6-2 Setting of acceleration

By adjustment of switch ⑦ and ⑧, the acceleration of actuator is set.

⑦ :Rotary switch to set acceleration of movement to the direction of the motor side.

⑧ :Rotary switch to set acceleration of movement to the direction of the end side.

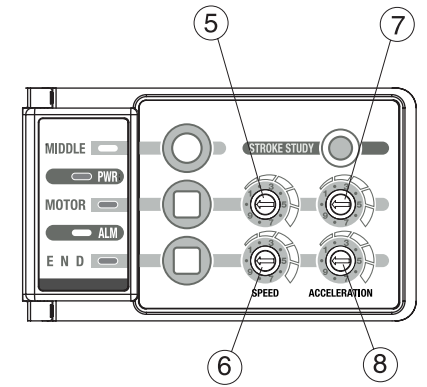
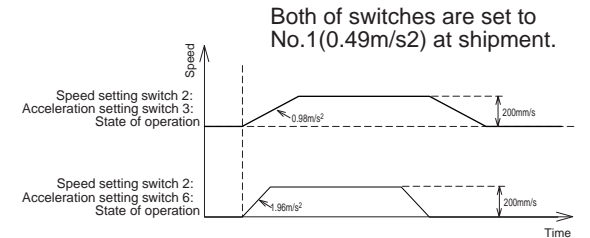
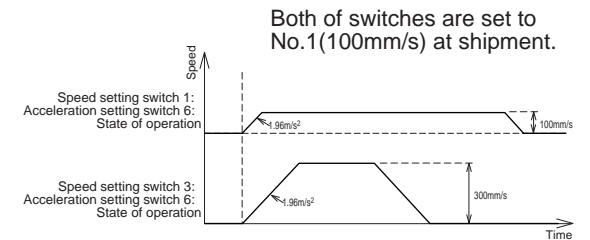

Figure.

Switch and speed, acceleration

Switch No.	Speed [mm/s]	Acceleration [mm/s ²]
1	100	0.49
2	200	0.74
3	300	0.98
4	400	1.23
5	500	1.47
6	600	1.96
7	700	2.45
8	800	2.94
9	900	3.92
10	1000	4.90

All switch No. of ex-factory is set at 1 (speed:100mm/s, acceleration 0.49m/s²).



Operation Characteristics

Application of power supply

When power supply is applied, the controller is initialized and then READY output is performed. If first transit of used power supply is 1s or more, the alarm output is performed in prior to initialization and READY output. If emergency stop input is released, READY output is not sent and alarm output is generated instead.

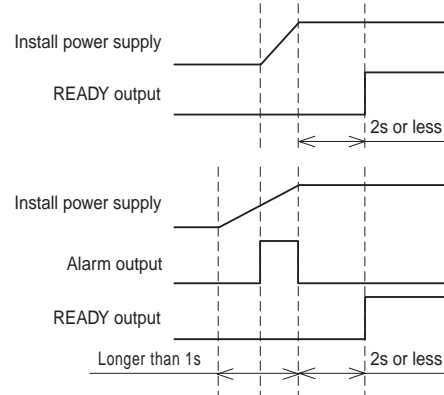

Movement to end

Ex.) Movement from motor side to end side

Do not turn off input of drive command until READY output is confirmed. The signal for completion of positioning is output when the actuator reaches the position 0.5mm before target position (indicated as A).

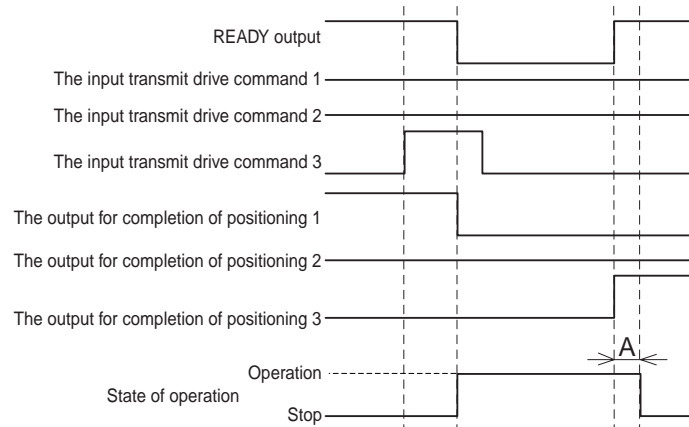

Intermediate operation

Ex.) Movement from motor side to intermediate 1

Do not turn off input of drive command until READY output is confirmed. The signal for completion of positioning is output when the actuator reaches the position 0.5mm before target position (indicated as A).

Ex.) Movement from motor side to intermediate 2

When operation command input 1 and 3 are input within 5ms, the operation of intermediate stop 2 starts. When it is longer than 5ms, the slider moves the motor side or intermediate stop 1. when the actuator reaches the position 0.5mm before target position (indicated as A).

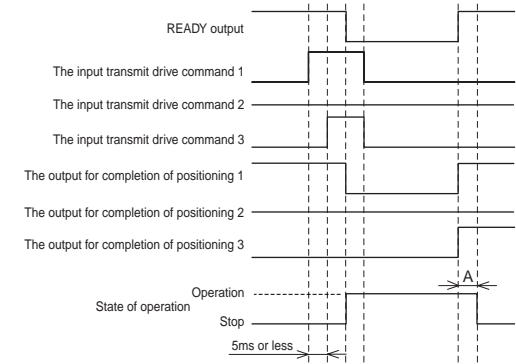
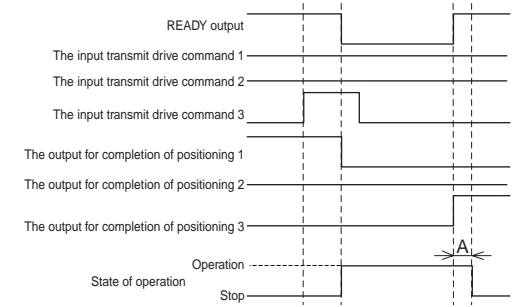

Other Functions

External input stop function

External input stop is the function to stop the slider by decelerating with the acceleration speed set by the acceleration speed set SW by means of stop command input from external device.

External input stop command more than 50ms. Signal does not necessary have to be pulse. Continuous input is acceptable.

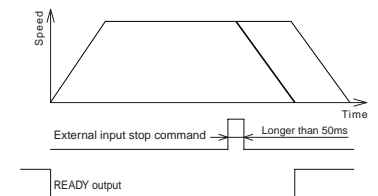

Specifications

● Standard specifications

Item		Specification	
Model		E-MY2 ※	
Nominal size		16	25
Maximum load weight ^(NOTE)		5kg	10kg
Transfer speed set range		100 to 1000 mm/s	
Transfer speed acceleration set range		0.49 to 4.90 m/s ²	
Acceleration and deceleration method		Trapezoidal drive	
Moving direction		Horizontal direction	
Positioning points		Both ends (mechanical stoppers), 3 intermediate position	
Repeated Positioning stopping precision	Both ends	±0.01mm	
	Intermediate stopping position	±0.1mm	
Intermediate stopping point positioning method		Direct teaching, JOG teaching	
Positioning setting spot		Controller body	
Display		LED for power supply, LED for alarming, LED for positioning completion	
Input signal		Actuation command signal, Emergency stop input signal	
Output signal		Positioning completion signal, Emergency detection signal, Ready signal	

NOTE) The maximum load weight shows the motor ability.

Please consider it together with the guide load factor when selecting a model.

● Electric Specification

Item		Specification	
Power supply for drive	Power supply voltage	DC24V ±10%	
	Current consumption	Max.5A(within 2s) normally 2.5A at DC24V	
Power supply for signal	Power supply voltage	DC24V ±10%	
	Current consumption	30mA + output load capacity at DC24V	
Input signal capacity		6mA or less / 1 circuit at DC24V(Photo-coupler input)	
Output load capacity		DC30V or less, 20mA or less / 1 circuit(opendrain output)	
Abnormal detection items		Emergency stop, Abnormal external output, Abnormal power supply, Abnormal drive, Abnormal temperature, Abnormal stroke, Abnormality of motor, Abnormality of controller	

● Environment specifications

Item		Specification	
Operating temperature range	Actuator	5 to 50 °C	
	Controller (separated type)	5 to 40 °C	
Operating humidity range		35 to 85%RH (with no condensation)	
Storage temperature range		-10 to 60 °C (with no condensation and freezing)	
Storage humidity range		35 to 85%RH (no condensation)	
Withstand voltage		Between all of external terminals and the case: 1000 VAC for 1 minute	
Insulation resistance		Between external terminal and case: 50 MΩ (500 VDC)	
Noise resistance		1000 Vp-p Pulse width 1 μs, Rise time 1 ns	

Common Functions

Lock function

If the set value of speed and acceleration need to be fixed, they can be locked. Set value of intermediate position is not locked.

•Lock

Press ① . then ③ within 3s. while pressing ① .
The lock function is set when this condition lasts over 1s and ALM and MOTOR start to blink.
If the lock is released, the operation returns to normal condition.

Note) Stroke learning starts when pressing ① only for 3s or longer.

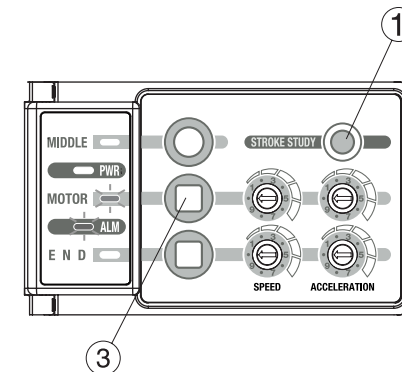

•Release

Press ① . then ④ within 3s. while pressing ① .
The lock function is set when this condition lasts over 1s and ALM and END start to blink.
If the lock is released, the operation returns to normal condition.

Note) Stroke learning starts when pressing ① only for 3s or longer.

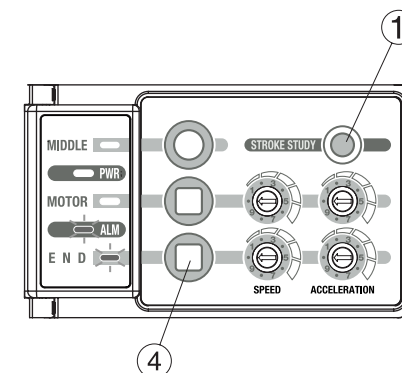

When changing the setting switch of speed and acceleration under locked condition, ALM indicator will blink.

Controller shows the following phenomena.

- Start operation with the set value at the lock condition.
- It is possible to release it. Change the setting value after the release
- Alarm signal is not output to external.

Alarm indication and remedy

Perform the following remedy when an alarm comes out.

Turning off blink Lighting

Point	Display	Content	Disposition
Emergency stop		Emergency stop input is opened or power supply for signal is cut off.	Confirm the power supply for signal is energized and release emergency stop input. (3 positions : See the circuit on page 13.) (5 positions : See the circuit on page 25.)
Abnormal external output		Abnormal external output. ※ Alarm signal is not output.	[Common power supply] Turn off power supply once to check the wiring condition of load and modify it if necessary. Then reapply the power supply. (3 positions : See the circuit on page 13.) (5 positions : See the circuit on page 25.)
			[Independent power supply] Turn off power supply for signal once to check the wiring condition of load and modify it if necessary. Then reapply the power supply and push MIDDLE button. (3 positions : See the circuit on page 13.) (5 positions : See the circuit on page 25.)
Abnormal power supply		Power supply voltage is excessive or lower than limit for operation.	Check the voltage and adjust it if necessary and then perform alarm reset.
Abnormal drive		Max. output is continued for prolonged period.	Check the weight of work and foreign material attached to actuating part and then perform alarm reset.
Abnormal temperature		Internal temperature of controller becomes excessive.	Decrease ambient temperature of the actuator and then perform alarm reset.

Point	Display	Content	Disposition
Abnormal stroke		The motor is revolving at excessive speed or stops before target stroke is achieved.	If foreign material is found, remove it and then perform alarm reset.
			Readjust stroke adjusting unit to the given stroke and perform stroke learning again after turning off the power supply. Note 1) When controller separate type is used, check connected part between motor and controller after turning off the power supply.
Abnormality of motor		The motor does not revolute properly or over current is detected.	Perform alarm reset. When controller separate type is used, check connected part between motor and controller after turning off the power supply.
Abnormality of controller		CPU is running way out of control or the content of memory is abnormal.	Turn off power supply once and then turn it on again.
Abnormality of setting value		Setting switch of speed and acceleration is changed under locked condition.	Return setting value of speed and acceleration to the one at the lock condition (See page 35 Lock function). ※ Alarm signal is not output.

Note 1): The product is in the condition same as after stroke learning is completed. The actuator does not return to original position by the first input of drive command.

•If the error can not be released, turn off power supply, stop use of the product and contact SMC sales responsibility.

General
3 positions
5 positions
General

Alarm reset

Alarm reset is available by manual alarm reset using ② and external alarm reset by external signal.
(See page 36, 37 and after for ALM display in case of alarm.)

Manual alarm reset

When alarm occur, press ② for recovery from alarm condition.

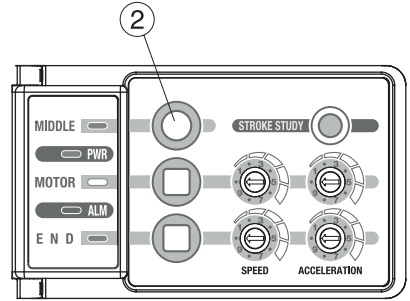

External alarm reset

Even if alarm occurs, it recovers from alarm condition by inputting emergency stop command externally for 50ms or more. Then operation is available.

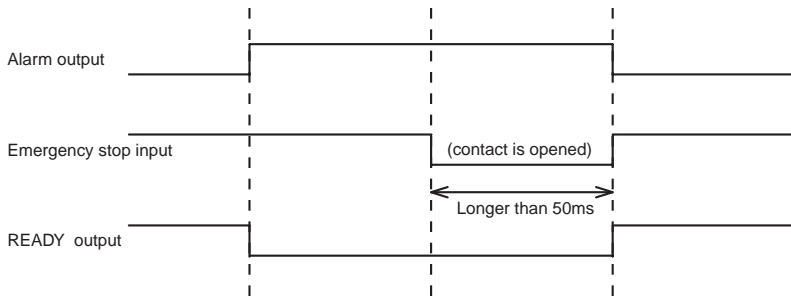

Recovery status is as below

- Slider is free from command until operation command is given.
- After recovery, operation command inputted next starts the operation. The moving speed of the first operation after the recovery is 50mm/s.