

### Standard Pressure Gauges



**K27A-P1.0-N01M**



**K40-MP1.0-N01MS**



**K50-MP1.0-N02MS**

\*Standard pressure gauges are stocked and readily available.

SIZE	27mm (1")		40mm (1 1/2")		50mm (2")	
THREAD LOCATION	CBM		CBM		CBM	
THREAD SIZE	1/8 NPT	1/8 PT	1/8 NPT	1/8 PT	1/4 NPT	1/4 PT
	WITH M5X0.8 FEMALE					
MATERIAL (CASE/SOCKET)	Urban White POLYAMID/POLYAMID		Urban White ABS/POLYAMID		Urban White ABS/POLYAMID	
UNITS	psi		Mpa & psi		Mpa & psi	
SCALE	PART NUMBER					
0~30 psi	K27A-P0.2-N01M	K27A-P0.2-01M	K40A-P0.2-N01M	K40A-P0.2-01M	K50A-P0.2-N02M	K50A-P0.2-02M
0~60 psi	K27A-P0.4-N01M	K27A-P0.4-01M	K40A-P0.4-N01M	K40A-P0.4-01M	K50A-P0.4-N02M	K50A-P0.4-02M
0~160 psi	K27A-P1.0-N01M	K27A-P1.0-01M	K40A-P1.0-N01M	K40A-P1.0-01M	K50A-P1.0-N02M	K50A-P1.0-02M

#### \*Important delivery information:

The part numbers listed on this page are standard stocked gauges. The delivery time on these standard gauges is approximately 1 week. Many other options can be made to order (see How to Order on proceeding page), but delivery time will be up to 14 weeks for the initial order. Subsequent orders for made to order gauges will be up to 10 weeks delivery depending on gauge options. If short delivery time is desired, SMC recommends choosing a part number from the list above instead of the proceeding page.



## Pressure/Vacuum Gauge Dimensions

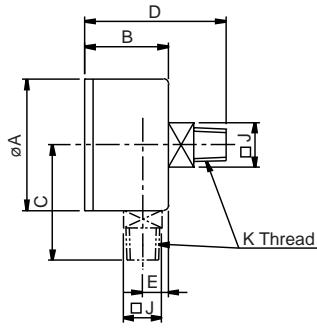

K(Z) <sup>(A)</sup>27 <sup>(A)</sup>40 <sup>(N)</sup>50 <sup>(P)</sup>—\*—(N)<sub>02</sub><sup>01</sup>  
 (D)50 (S)

Series	A	B	C 1/8 THD	C 1/4THD	D 1/8 THD	D 1/4 THD	E	F	G	H	J	K	L	M	N
1" K27A	1.10 (28)	.65 (16.5)	—	—	1.06 (27)	—	—	—	—	—	—	1/8 PT or NPT	—	—	—
1" K27 <sup>N</sup> <sub>S</sub>	1.10 (28)	.67 (17)	—	—	1.06 (27)	—	—	—	—	—	—	1/8 PT or NPT	—	—	—
1 1/2" K(Z)40(A)	1.61 (41)	1.02 (26)	—	—	1.73 (44)	1.85 (47)	—	—	—	—	.55 (14)	1/8 or 1/4 PT or NPT	—	—	—
2" K(Z)50(A)	1.93 (49)	1.04 (26.5)	—	—	1.75 (44.5)	1.87 (47.5)	—	—	—	—	.55 (14)	1/8 or 1/4 PT or NPT	—	—	—
1 1/2" K(Z)40 <sup>N</sup> <sub>S</sub>	1.57 (40)	1.04 (26.5)	—	—	1.63 (41.5)	1.75 (44.5)	—	—	—	—	.55 (14)	1/8 or 1/4 PT or NPT	—	—	—
2" K(Z)50 <sup>N</sup> <sub>S</sub>	1.93 (49)	1.06 (27)	—	—	1.79 (45.5)	1.91 (48.5)	—	—	—	—	.55 (14)	1/8 or 1/4 PT or NPT	—	—	—
1 1/2" K(Z) <sup>A</sup> 40 <sup>B</sup> 40 <sup>C</sup> 40 <sup>D</sup> 40(A)	1.57 (40)	.91 (23)	1.42 (36)	—	—	—	.31 (8)	—	—	—	.47 (12)	1/8 PT or NPT	—	—	—
2" K(Z) <sup>A</sup> 50 <sup>B</sup> 50 <sup>C</sup> 50 <sup>D</sup> 50(A)	1.93 (49)	1.06 (27)	1.65 (42)	1.77 (45)	—	—	.39 (10)	—	—	—	.55 (14)	1/8 or 1/4 PT or NPT	—	—	—
1 1/2" K(Z) <sup>A</sup> 40 <sup>B</sup> 40 <sup>C</sup> 40 <sup>D</sup> 40 <sup>N</sup> <sub>S</sub>	1.54 (39)	.91 (23)	1.42 (36)	—	—	—	.31 (8)	—	—	—	.47 (12)	1/8 PT or NPT	—	—	—
2" K(Z) <sup>A</sup> 50 <sup>B</sup> 50 <sup>C</sup> 50 <sup>D</sup> 50 <sup>N</sup> <sub>S</sub>	1.93 (49)	1.06 (27)	1.63 (41.5)	1.75 (44.5)	—	—	.39 (10)	—	—	—	.55 (14)	1/8 or 1/4 PT or NPT	—	—	—

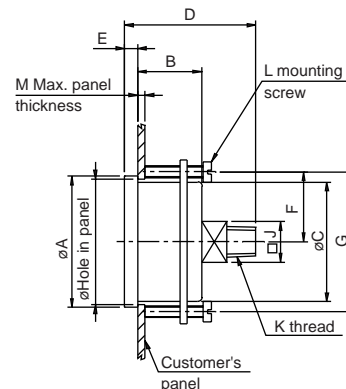
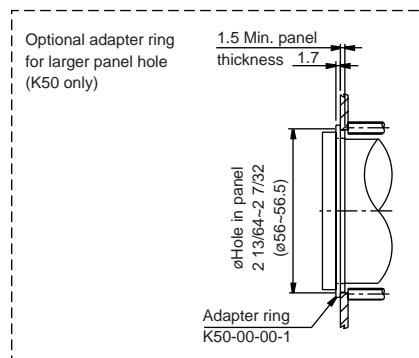

K(Z) <sup>40</sup>50 <sup>(P)</sup>—\*—(N)<sub>02</sub><sup>01</sup>—C

Series	A	B	C	D 1/8 NPT	D 1/4 NPT	E	F	G	J	K	L	M	øHole	
													Min.	Max.
1 1/2" K(Z)40	1.77 (45)	.87 (22)	1.57 (40)	1.77 (45)	1.89 (48)	.18 (4.5)	.94 (24)	1.89 (48)	.55 (14)	1/8 or 1/4 PT or NPT	M4X0.7X20 Slotted Cheese Head	9/16 (14)	1 19/32 (40.5)	1 21/32 (42)
2" K(Z)50	2.13 (54)	.87 (22)	1.95 (49.5)	1.77 (45)	1.89 (48)	.18 (4.5)	1.12 (28.5)	2.24 (57)	.55 (14)	1/8 or 1/4 PT or NPT	M4X0.7X20 Slotted Cheese Head	37/64 (14.5)	1 31/32 (50)	2 1/32 (51.5)

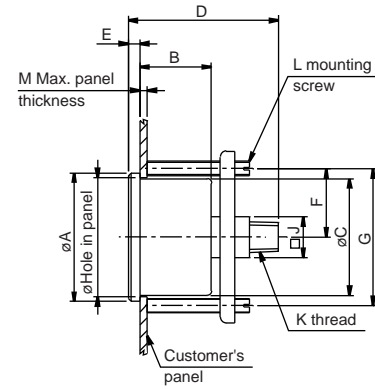
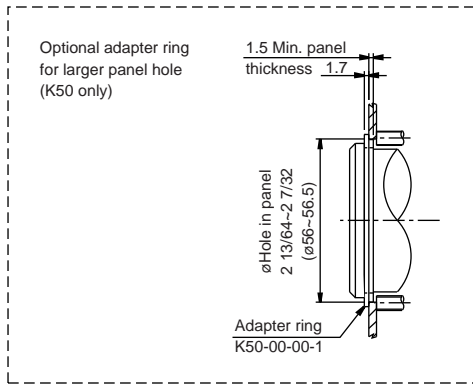

**K(Z)** <sup>40</sup>/<sub>50</sub> <sup>N</sup>/<sub>S</sub> —\*—(N) <sup>01</sup>/<sub>02</sub> —C

Series	A	B	C	D		E	F	G	J	K	L	M	∅Hole	
				1/8 NPT	1/4 NPT								Min.	Max.
<b>1 1/2"</b> <b>K(Z)40</b>	1.73 (44)	.96 (24.5)	1.57 (40)	2.03 (51.5)	2.15 (54.5)	.16 (4)	.93 (23.5)	1.85 (47)	.55 (14)	1/8 or 1/4 PT or NPT	M5X0.8X35L Slotted Set	1.08 (27.5)	1 19/32 (40.5)	1 5/8 (41)
<b>2"</b> <b>K(Z)50</b>	2.13 (54)	.96 (24.5)	1.93 (49)	2.07 (52.5)	2.19 (55.5)	2 (5)	1.11 (28.25)	2.22 (56.5)	.55 (14)	1/8 or 1/4 PT or NPT	M5X0.8X35 Slotted Set	1.0 (25.5)	1 15/16 (49.5)	1 31/32 (50)