

Compact Cylinder Series *NCQ8*

Bore size: 056 (9/16"), 075 (3/4"), 106 (1-1/16"), 150 (1-1/2"), 200 (2"), 250 (2-1/2")



Standard type	Actuation	Style		Bore size	Standard stroke (inch)	Page			
	Double acting	Single rod	○	056 (9/16") 075 (3/4") 106 (1-1/16") 150 (1-1/2") 200 (2") 250 (2-1/2")	012 (1/8"), 025 (1/4"), 037 (3/8"), 050 (1/2"), 062 (5/8"), 075 (3/4"), 087 (7/8"), 100 (1"), 125 (1-1/4"), 150 (1-1/2"), 175 (1-3/4"), 200 (2"), 250 (2-1/2"), 300 (3"), 350 (3-1/2"), 400 (4")	1			
		Double rod	○			13			
	Single acting	Single rod	○			012 (1/8"), 025 (1/4"), 037 (3/8"), 050 (1/2"), 062 (5/8"), 075 (3/4"), 087 (7/8"), 100 (1"), 125 (1-1/4"), 150 (1-1/2"), 175 (1-3/4"), 200 (2")	22		
	Double acting	Single rod	★ ○			056 (9/16") 075 (3/4") 106 (1-1/16") 150 (1-1/2") 200 (2") 250 (2-1/2")	025 (1/4"), 037 (3/8"), 050 (1/2"), 062 (5/8"), 075 (3/4"), 087 (7/8"), 100 (1"), 125 (1-1/4"), 150 (1-1/2"), 175 (1-3/4"), 200 (2"), 250 (2-1/2"), 300 (3"), 350 (3-1/2"), 400 (4")	1	
		Single acting	Single rod					★ ○	025 (1/4"), 037 (3/8"), 050 (1/2"), 062 (5/8"), 075 (3/4"), 087 (7/8"), 100 (1"), 125 (1-1/4"), 150 (1-1/2"), 175 (1-3/4"), 200 (2")

Note) Built-in magnet type has a minimum stroke of 025 (1/4").

★ Super Compact type is only available with a magnet.

COMPACT CYLINDER

- Square body allows close center to center mounting
- Visibility of auto switch is improved.
- Auto switch mountable on multiple-sides
- No protrusion from cylinder's exterior when mounting auto switches

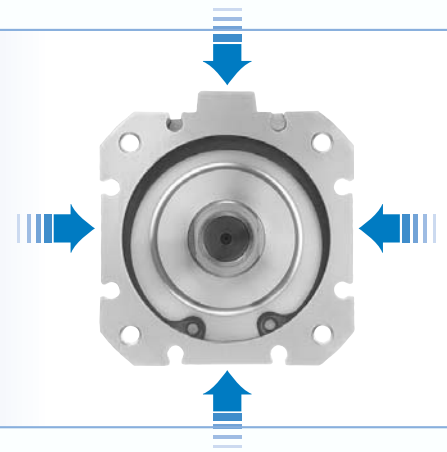

Snap ring design allows for quick and easy maintenance.
Just by removing the snap ring and collar, seal replacement is possible.

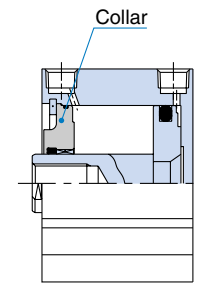
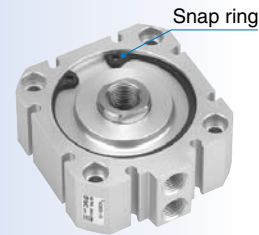

Super Compact type is available - saves additional space.

NCDQ8□
With auto switch,
Standard type

Difference in dimension (in)

NCDQ8□Z
With auto switch,
Super compact type

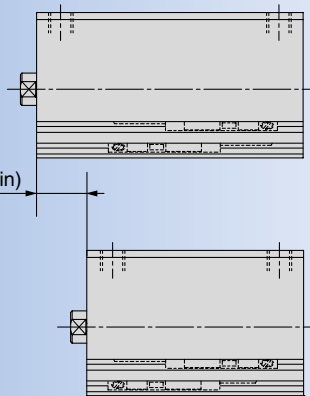

Bore size	Cylinder tube whole length (in)*		Difference in dimension (in)
	NCDQ8□	NCDQ8□Z	
056 (9/16")	1.44	1.06	0.38
075 (3/4")	1.44	1.06	0.38
106 (1-1/16")	1.75	1.25	0.50
150 (1-1/2")	1.75	1.25	0.50
200 (2")	1.81	1.19	0.62
250 (2-1/2")	2.06	1.44	0.62

*Indicates the dimension for 0 (zero) stroke of double acting, single rod.

Series
NCDQ8



Compact Cylinder Double Acting, Single Rod Series **NCQ8**

Bore size: 056 (9/16"), 075 (3/4"), 106 (1-1/16"), 150 (1-1/2"), 200 (2"), 250 (2-1/2")

How to Order

Without auto switch

NCQ8 B

056

025

056

025

M9B S

With auto switch

NCDQ8 B Z 056 025 M9B S

Built-in magnet

Mounting

B	Through-hole
A	Both ends tapped
C	Rear clevis
E	Front screw clearance hole
M	Rear screw clearance hole
N	Through screw clearance hole

Overall length type

Nil	Standard
Z	Super compact

Nominal bore size

056	9/16"
075	3/4"
106	1-1/16"
150	1-1/2"
200	2"
250	2-1/2"

Cylinder stroke (in)

Symbol	Stroke	Symbol	Stroke	Symbol	Stroke	Symbol	Stroke
012	1/8"	062	5/8"	125	1-1/4"	250	2-1/2"
025	1/4"	075	3/4"	150	1-1/2"	300	3"
037	3/8"	087	7/8"	175	1-3/4"	350	3-1/2"
050	1/2"	100	1"	200	2"	400	4"

Note 1) With switch is available on strokes 025(1/4") and greater.

X-Option

Nil	Standard
XB6 ^{Note 4)}	High temp.
XC4	With scraper

Note 4) XB6: Not available with magnet.
*For detailed made to order specifications, refer to page 46.

Number of auto switches

Nil	2 pcs.
S	1 pc.
n	"n" pcs.

Auto switch type

Nil	Without auto switch (Built-in magnet cylinder)
------------	--

*Refer to the table below for auto switch model numbers.
*Auto switches are shipped together, (but not assembled).

Body option

Nil	Standard (Female rod end)
C ^{Note 2, 3)}	Rubber bumper
M	Male rod end

Note 2) Rubber bumper is not available with type "Z" (Super Compact type). Consult with your SMC sales representative.
Note 3) Stroke will be reduced by 0.06" for rubber bumper type.
*Combination of body options (CM) is available.

Applicable Auto Switches

Type	Special function	Electrical entry	Indicator/light	Wiring (output)	Load voltage			Auto switch model		Lead wire length (in)*			Applicable load													
					DC		AC	Perpendicular	In-line	20 (0.5m) (Nil)	118 (3m) (L)	197 (5m) (Z)														
					—	5 V	—																			
Reed switch	—	Grommet	Yes	3-wire (NPN equiv.)	—	5 V	—	A96V	A96	●	●	—	IC circuit	—												
															No	2-wire	24 V	5 V, 12 V	100 V	A90V	A90	●	●	—	IC circuit	Relay, PLC
Solid state switch	—	Grommet	Yes	3-wire (NPN)	24 V	5 V, 12 V	—	M9NV	M9N	●	●	○	IC circuit	Relay, PLC												
				3-wire (PNP)											12 V	M9PV	M9P	●	●	○						
				2-wire																	5 V, 12 V	M9BV	M9B	●	●	○
				3-wire (NPN)											12 V	F9NWV	F9NW	●	●	○						
				3-wire (PNP)																						
				2-wire											—	—	—	—	—	—	—					
				Water resistant (2-color display)											—	—	—	—	—	—	—	—	—	—	—	—
—	—	—	—	—	—	—	—	—	—	—	—	—	—													

*Lead wire length symbols: 20in (0.5 m) Nil (Example) M9N
 118in (3 m) L M9NL
 197in (5 m) Z M9NZ

*Solid state switches marked with a "O" symbol are produced upon receipt of order.

Series NCQ8

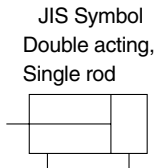

Specifications

Bore size	056 (9/16")	075 (3/4")	106 (1-1/16")	150 (1-1/2")	200 (2")	250 (2-1/2")
Piping size	#10-32UNF	#10-32UNF	NPT1/8	NPT1/8	NPT1/8	NPT1/4
Type	Pneumatic (Non-lube)					
Action	Double acting, Single rod					
Fluid	Air					
Proof pressure	300PSI (2.1MPa)					
Maximum operating pressure	200PSI (1.4MPa)					
Minimum operating pressure	056	11PSI (0.07MPa)				
	075 to 250	8PSI (0.05MPa)				
Ambient and fluid temperature	Without auto switch	15 to 150°F (-10 to 65°C) (No freezing)				
	With switch	15 to 140°F (-10 to 60°C) (No freezing)				
Cushion	Rubber bumper					
Rod end thread	Female thread					
Rod end thread tolerance	Class 2					
Stroke tolerance	0 to +0.04 in (+1.0mm)					
Mounting	Through-hole (B), Both ends tapped (A), Clevis SCH (E, M, N)					
Piston speed	2 to 20in/sec (50 to 500mm/s)					

* Since a rubber bumper is not available with Z (Total length shorten type), please consult with us separately.

Applicable Stroke

Unit: inch

Bore size	Standard stroke
056 (9/16")	012 (1/8"), 025 (1/4"), 037 (3/8"), 050 (1/2") 062 (5/8"), 075 (3/4"), 087(7/8"), 100 (1") 125 (1-1/4"), 150(1-1/2"), 175(1-3/4"), 200 (2") 250 (2-1/2"), 300 (3"), 350 (3-1/2"), 400 (4")
075 (3/4")	
106 (1-1/16")	
150 (1-1/2")	
200 (2")	
250 (2-1/2")	

* With switch is available on strokes 025 (1/4") and greater.

Theoretical Output Table

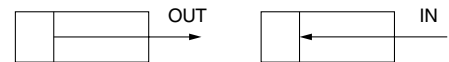

Unit: lbs

Bore size (in)	Operating direction	Operating pressure/PSI (MPa)			
		45 (0.3)	75 (0.5)	145 (1.0)	200 (1.4)
056 (9/16")	IN	8.87	14.6	28.6	39.2
	OUT	11.1	18.2	35.7	48.9
075 (3/4")	IN	16.4	27.0	52.9	72.5
	OUT	19.9	32.7	64.1	87.8
106 (1-1/16")	IN	30.8	50.8	99.5	136
	OUT	39.7	65.3	128	175
150 (1-1/2")	IN	65.7	108	212	290
	OUT	79.5	131	256	351
200 (2")	IN	121	200	391	536
	OUT	141	232	456	624
250 (2-1/2")	IN	201	330	648	888
	OUT	221	363	712	975

Weights

Double Acting, Single Rod Without Switch

(OZ)

Stroke Model	012 (1/8")	025 (1/4")	037 (3/8")	050 (1/2")	062 (5/8")	075 (3/4")	087 (7/8")	100 (1")	125 (1-1/4")	150 (1-1/2")	175 (1-3/4")	200 (2")	250 (2-1/2")	300 (3")	350 (3-1/2")	400 (4")
NCQ8□056-□	0.82	0.96	1.10	1.24	1.38	1.52	1.66	1.80	2.09	2.37	2.65	2.93	3.50	4.06	4.63	5.19
NCQ8□075-□	1.24	1.45	1.66	1.86	2.07	2.28	2.49	2.70	3.11	3.53	3.94	4.36	5.19	6.03	6.86	7.69
NCQ8□106-□	3.27	3.64	4.01	4.38	4.75	5.12	5.49	5.86	6.60	7.34	8.08	8.82	10.3	11.8	13.3	14.8
NCQ8□150-□	5.30	5.84	6.37	6.91	7.45	7.99	8.53	9.07	10.2	11.3	12.4	13.4	15.6	17.8	19.9	22.1
NCQ8□200-□	8.89	9.69	10.5	11.3	12.1	12.9	13.7	14.5	16.1	17.7	19.3	20.8	24.0	27.2	30.4	33.5
NCQ8□250-□	14.3	15.1	15.9	16.7	17.5	18.3	19.1	20.0	21.6	23.2	24.8	26.6	29.6	33.2	36.1	39.3

Double Acting, Single Rod, With Switch

(OZ)

Stroke Model	012 (1/8")	025 (1/4")	037 (3/8")	050 (1/2")	062 (5/8")	075 (3/4")	087 (7/8")	100 (1")	125 (1-1/4")	150 (1-1/2")	175 (1-3/4")	200 (2")	250 (2-1/2")	300 (3")	350 (3-1/2")	400 (4")
NCDQ8□056-□	—	2.14	2.28	2.42	2.56	2.70	2.84	2.99	3.27	3.55	3.83	4.11	4.68	5.24	5.81	6.37
NCDQ8□075-□	—	3.35	3.56	3.77	3.98	4.18	4.39	4.60	5.02	5.43	5.85	6.27	7.10	7.93	8.76	9.59
NCDQ8□106-□	—	6.99	7.36	7.73	8.10	8.47	8.84	9.21	9.95	10.7	11.5	12.2	13.7	15.2	16.7	18.1
NCDQ8□150-□	—	11.4	11.9	12.5	13.0	13.5	14.1	14.6	15.7	16.8	17.9	18.9	21.1	23.3	25.4	27.6
NCDQ8□200-□	—	17.9	18.7	19.5	20.3	21.1	21.9	22.7	24.2	25.8	27.4	29.0	32.2	35.4	38.5	41.7
NCDQ8□250-□	—	25.3	26.1	26.9	27.7	28.5	29.3	30.1	31.8	33.4	35.0	36.6	39.9	43.1	46.4	49.6

Double Acting, Single Rod, With Switch, Super Compact

(OZ)

Stroke Model	012 (1/8")	025 (1/4")	037 (3/8")	050 (1/2")	062 (5/8")	075 (3/4")	087 (7/8")	100 (1")	125 (1-1/4")	150 (1-1/2")	175 (1-3/4")	200 (2")	250 (2-1/2")	300 (3")	350 (3-1/2")	400 (4")
NCDQ8□Z056-□	—	1.61	1.75	1.89	2.03	2.17	2.32	2.46	2.74	3.02	3.30	3.58	4.15	4.71	5.28	5.84
NCDQ8□Z075-□	—	2.52	2.73	2.94	3.15	3.36	3.56	3.77	4.19	4.60	5.02	5.44	6.27	7.10	7.93	8.77
NCDQ8□Z106-□	—	5.05	5.42	5.79	6.16	6.53	6.90	7.27	8.01	8.75	9.49	10.3	11.8	13.2	14.7	16.2
NCDQ8□Z150-□	—	8.13	8.67	9.21	9.75	10.3	10.9	11.4	12.5	13.6	14.7	15.7	17.9	20.1	22.2	24.4
NCDQ8□Z200-□	—	12.4	13.2	14.0	14.8	15.6	16.4	17.2	18.8	20.4	22.0	23.5	26.7	29.9	33.1	36.2
NCDQ8□Z250-□	—	18.6	19.4	20.2	21.0	21.8	22.7	23.5	25.1	26.7	28.3	30.0	33.2	36.4	39.7	42.9

Option Weights

Unit: OZ

Bore size	Clevis
056 (9/16")	0.71
075 (3/4")	0.93
106 (1-1/16")	1.64
150 (1-1/2")	4.16
200 (2")	6.04
250 (2-1/2")	8.74

⚠ Specific Product Precautions

Be sure to read before handling.

For Safety Instructions and Common Precautions, refer to pages 56 through 61.

⚠ Caution

Snap Ring Installation/Removal

1. For installation and removal, use an appropriate pair of pliers (Tool for installing a type C snap ring).
2. Even if a proper plier (tool for installing type C snap ring) is used, it is likely to inflict damage to a human body or peripheral equipment, as a

snap ring may be flown out of the tip of a plier (tool for installing a type C snap ring). Be much careful with the popping of a snap ring. Besides, be certain that a snap ring is placed firmly into the groove of rod cover before supplying air at the time of installment. After re-installing the cylinder, make sure that the snap ring is placed securely in the groove before supplying air.

Allowable kinetic energy

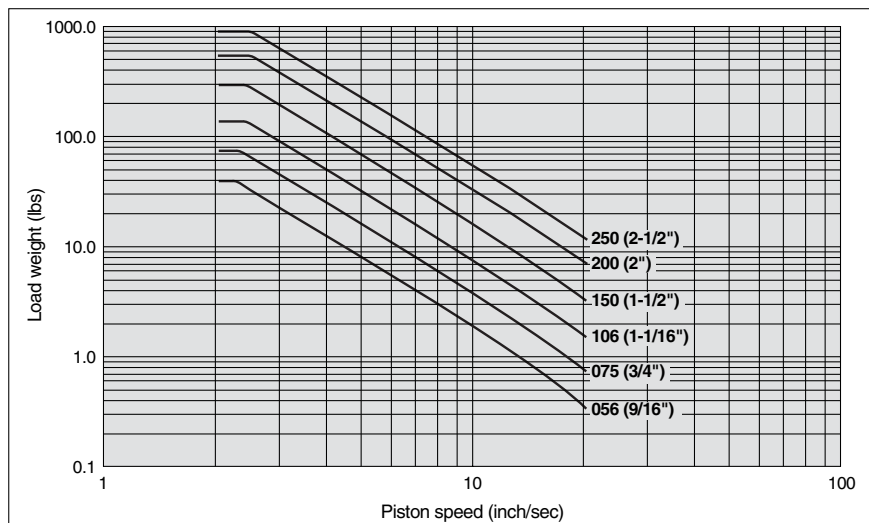

Allowable lateral load at rod end

Without Auto Switch

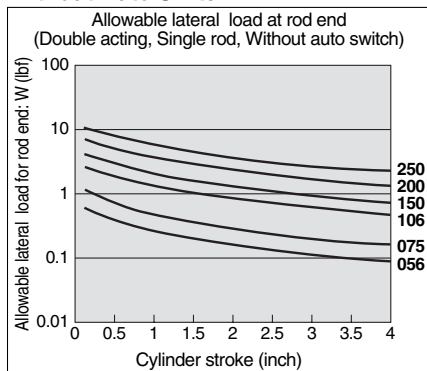

With Auto Switch

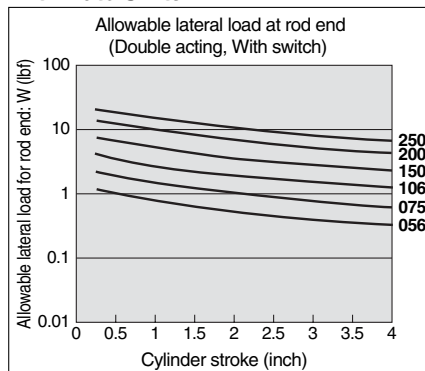

With Auto Switch, Super Compact

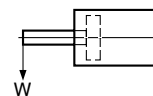
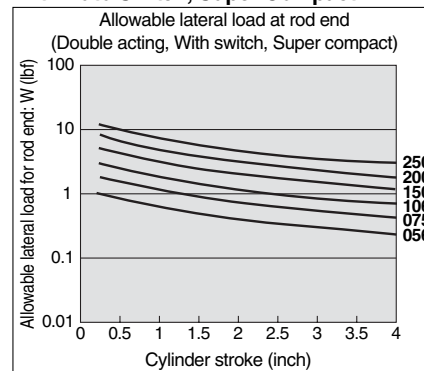

(Mounting orientation: Horizontal)

Compact Cylinder Double Acting, Single Rod **Series NCQ8**

Mounting Bolt

Mounting method: Mounting bolt for through-hole style of NCQ8B is available as an option.

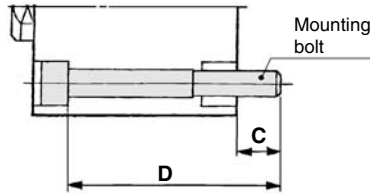

Mounting Bolt Size for NCQ8B056 to 250-□ (Without Auto Switch)

(Inch)

Model	C	D	Bolt size
NCQ8B056-012	0.18	3/4	#4-40UNC- 3/4
025		7/8	7/8
037		1	1
050		1-1/8	1-1/8
062		1-1/4	1-1/4
075		1-3/8	1-3/8
087		1-1/2	1-1/2
100		1-5/8	1-5/8
125		1-7/8	1-7/8
150		2-1/8	2-1/8
175		2-3/8	2-3/8
200		2-5/8	2-5/8
250		3-1/8	3-1/8
300		3-5/8	3-5/8
350		4-1/8	4-1/8
400		4-5/8	4-5/8
NCQ8B075-012	0.21	3/4	#6-32UNC- 3/4
025		7/8	7/8
037		1	1
050		1-1/8	1-1/8
062		1-1/4	1-1/4
075		1-3/8	1-3/8
087		1-1/2	1-1/2
100		1-5/8	1-5/8
125		1-7/8	1-7/8
150		2-1/8	2-1/8
175		2-3/8	2-3/8
200		2-5/8	2-5/8
250		3-1/8	3-1/8
300		3-5/8	3-5/8
350		4-1/8	4-1/8
400		4-5/8	4-5/8
NCQ8B106-012	0.27	1-1/8	#6-32UNC- 1-1/8
025		1-1/4	1-1/4
037		1-3/8	1-3/8
050		1-1/2	1-1/2
062		1-5/8	1-5/8
075		1-3/4	1-3/4
087		1-7/8	1-7/8
100		2	2
125		2-1/4	2-1/4
150		2-1/2	2-1/2
175		2-3/4	2-3/4
200		3	3
250		3-1/2	3-1/2
300		4	4
350		4-1/2	4-1/2
400		5	5

Model	C	D	Bolt size
NCQ8B150-012	0.33	1-1/8	#10-24UNC- 1-1/8
025		1-1/4	1-1/4
037		1-3/8	1-3/8
050		1-1/2	1-1/2
062		1-5/8	1-5/8
075		1-3/4	1-3/4
087		1-7/8	1-7/8
100		2	2
125		2-1/4	2-1/4
150		2-1/2	2-1/2
175		2-3/4	2-3/4
200		3	3
250		3-1/2	3-1/2
300		4	4
350		4-1/2	4-1/2
400		5	5
NCQ8B200-012	0.39	1-1/4	#10-24UNC- 1-1/4
025		1-3/8	1-3/8
037		1-1/2	1-1/2
050		1-5/8	1-5/8
062		1-3/4	1-3/4
075		1-7/8	1-7/8
087		2	2
100		2-1/8	2-1/8
125		2-3/8	2-3/8
150		2-5/8	2-5/8
175		2-7/8	2-7/8
200		3-1/8	3-1/8
250		3-5/8	3-5/8
300		4-1/8	4-1/8
350		4-5/8	4-5/8
400		5-1/8	5-1/8
NCQ8B250-012	0.45	1-1/2	1/4-20UNC- 1-1/2
025		1-5/8	1-5/8
037		1-3/4	1-3/4
050		1-7/8	1-7/8
062		2	2
075		2-1/8	2-1/8
087		2-1/4	2-1/4
100		2-3/8	2-3/8
125		2-5/8	2-5/8
150		2-7/8	2-7/8
175		3-1/8	3-1/8
200		3-3/8	3-3/8
250		3-7/8	3-7/8
300		4-3/8	4-3/8
350		4-7/8	4-7/8
400		5-3/8	5-3/8

Series NCQ8

Mounting Bolt

Mounting method: Mounting bolt for through-hole style of NCQ8 is available as an option.

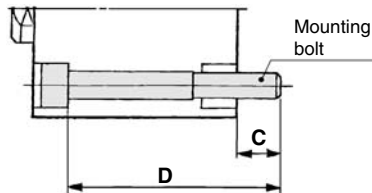

Mounting Bolt Size for NCDQ8B056 to 250-□ (With Auto Switch)

(Inch)

Model	C	D	Bolt size
NCDQ8B056-025	0.18	1-3/4	#4-40UNC-1-3/4
037		1-7/8	1-7/8
050		2	2
062		2-1/8	2-1/8
075		2-1/4	2-1/4
087		2-3/8	2-3/8
100		2-1/2	2-1/2
125		2-3/4	2-3/4
150		3	3
175		3-1/4	3-1/4
200		3-1/2	3-1/2
250		4	4
300		4-1/2	4-1/2
350		5	5
400		5-1/2	5-1/2
NCDQ8B075-025		0.21	1-3/4
037	1-7/8		1-7/8
050	2		2
062	2-1/8		2-1/8
075	2-1/4		2-1/4
087	2-3/8		2-3/8
100	2-1/2		2-1/2
125	2-3/4		2-3/4
150	3		3
175	3-1/4		3-1/4
200	3-1/2		3-1/2
250	4		4
300	4-1/2		4 1/2
350	5		5
400	5-1/2		5-1/2
NCDQ8B106-025	0.27		2-1/8
037		2-1/4	2-1/4
050		2-3/8	2-3/8
062		2-1/2	2-1/2
075		2-5/8	2-5/8
087		2-3/4	2-3/4
100		2-7/8	2-7/8
125		3-1/8	3-1/8
150		3-3/8	3-3/8
175		3-5/8	3-5/8
200		3-7/8	3-7/8
250		4-3/8	4-3/8
300		4-7/8	4-7/8
350		5-3/8	5-3/8
400		5-7/8	5-7/8

Model	C	D	Bolt size
NCDQ8B150-025	0.33	2-1/8	#10-24UNC-2-1/8
037		2-1/4	2-1/4
050		2-3/8	2-3/8
062		2-1/2	2-1/2
075		2-5/8	2-5/8
087		2-3/4	2-3/4
100		2-7/8	2-7/8
125		3-1/8	3-1/8
150		3-3/8	3-3/8
175		3-5/8	3-5/8
200		3-7/8	3-7/8
250		4-3/8	4-3/8
300		4-7/8	4-7/8
350		5-3/8	5-3/8
400		5-7/8	5-7/8
NCDQ8B200-025		0.39	2-1/4
037	2-3/8		2-3/8
050	2-1/2		2-1/2
062	2-5/8		2-5/8
075	2-3/4		2-3/4
087	2-7/8		2-7/8
100	3		3
125	3-1/4		3-1/4
150	3-1/2		3-1/2
175	3-3/4		3-3/4
200	4		4
250	4-1/2		4-1/2
300	5		5
350	5-1/2		5-1/2
400	6		6
NCDQ8B250-025	0.45		2-1/2
037		2-5/8	2-5/8
050		2-3/4	2-3/4
062		2-7/8	2-7/8
075		3	3
087		3-1/8	3-1/8
100		3-1/4	3-1/4
125		3-1/2	3-1/2
150		3-3/4	3-3/4
175		4	4
200		4-1/4	4-1/4
250		4-3/4	4-3/4
300		5-1/4	5-1/4
350		5-3/4	5-3/4
400		6-1/4	6-1/4

Compact Cylinder Double Acting, Single Rod **Series NCQ8**

Mounting Bolt

Mounting method: Mounting bolt for through-hole style of NCQ8 is available as an option.

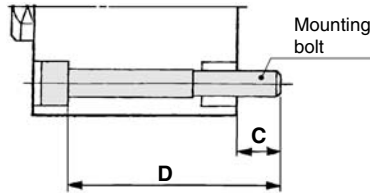

Mounting Bolt size for NCDQ8BZ056 to 250-□ (With Auto Switch)

(Inch)

Model	C	D	Bolt size
NCDQ8BZ056-025	0.18	1-3/8	#4-40UNC- 1-3/8
037		1-1/2	1-1/2
050		1-5/8	1-5/8
062		1-3/4	1-3/4
075		1-7/8	1-7/8
087		2	2
100		2-1/8	2-1/8
125		2-3/8	2-3/8
150		2-5/8	2-5/8
175		2-7/8	2-7/8
200		3-1/8	3-1/8
250		3-5/8	3-5/8
300		4-1/8	4-1/8
350		4-5/8	4-5/8
400		5-1/8	5-1/8
NCDQ8BZ075-025		0.21	1-3/8
037	1-1/2		1-1/2
050	1-5/8		1-5/8
062	1-3/4		1-3/4
075	1-7/8		1-7/8
087	2		2
100	2-1/8		2-1/8
125	2-3/8		2-3/8
150	2-5/8		2-5/8
175	2-7/8		2-7/8
200	3-1/8		3-1/8
250	3-5/8		3-5/8
300	4-1/8		4-1/8
350	4-5/8		4-5/8
400	5-1/8		5-1/8
NCDQ8BZ106-025	0.27		1-5/8
037		1-3/4	1-3/4
050		1-7/8	1-7/8
062		2	2
075		2-1/8	2-1/8
087		2-1/4	2-1/4
100		2-3/8	2-3/8
125		2-5/8	2-5/8
150		2-7/8	2-7/8
175		3-1/8	3-1/8
200		3-3/8	3-3/8
250		3-7/8	3-7/8
300		4	4
350		4-1/2	4-1/2
400		5	5

Model	C	D	Bolt size
NCDQ8BZ150-025	0.33	1-5/8	#10-24UNC- 1-5/8
037		1-3/4	1-3/4
050		1-7/8	1-7/8
062		2	2
075		2-1/8	2-1/8
087		2-1/4	2-1/4
100		2-3/8	2-3/8
125		2-5/8	2-5/8
150		2-7/8	2-7/8
175		3-1/8	3-1/8
200		3-3/8	3-3/8
250		3-7/8	3-7/8
300		4-3/8	4-3/8
350		4-7/8	4-7/8
400		5-3/8	5-3/8
NCDQ8BZ200-025		0.39	1-5/8
037	1-3/4		1-3/4
050	1-7/8		1-7/8
062	2		2
075	2-1/8		2-1/8
087	2-1/4		2-1/4
100	2-3/8		2-3/8
125	2-5/8		2-5/8
150	2-7/8		2-7/8
175	3-1/8		3-1/8
200	3-3/8		3-3/8
250	3-7/8		3-7/8
300	4-3/8		4-3/8
350	4-7/8		4-7/8
400	5-3/8		5-3/8
NCDQ8BZ250-025	0.45		1-7/8
037		2	2
050		2-1/8	2-1/8
062		2-1/4	2-1/4
075		2-3/8	2-3/8
087		2-1/2	2-1/2
100		2-5/8	2-5/8
125		2-7/8	2-7/8
150		3-1/8	3-1/8
175		3-3/8	3-3/8
200		3-5/8	3-5/8
250		4-1/8	4-1/8
300		4-5/8	4-5/8
350		5-1/8	5-1/8
400		5-5/8	5-5/8

Series NCQ8

Construction

Without auto switch

Here is the typical, cross-sectional construction. For details for each model, refer to the instruction manual.

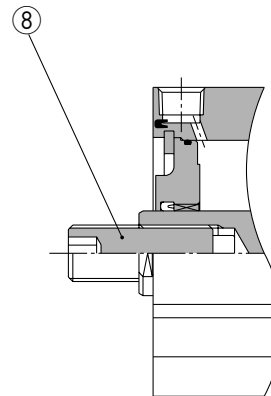
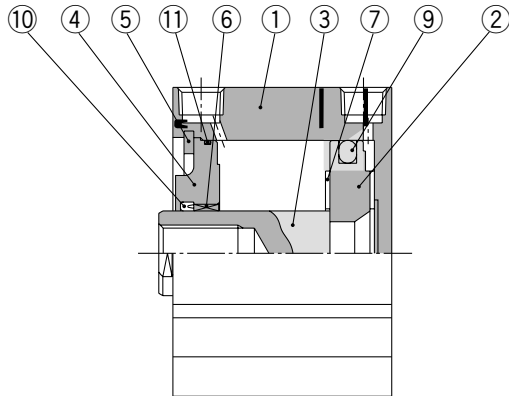

Male thread

Parts List

No.	Description	Material	Remarks
1	Cylinder tube	Aluminum alloy	Hard anodized
2	Piston	Aluminum alloy	Chromated
3	Piston rod	Stainless steel	056 to 106
		Carbon steel	150 to 250 Hard chrome plated
4	Collar	Aluminum alloy	Anodized
5	Snap ring	Carbon tool steel	Phosphate coated

No.	Description	Material	Remarks
6	Bushing	Phosphor bronze alloy	200 and 250 only
7	Rubber bumper	NBR	With rubber bumper only
8	Stud	Steel alloy	Electroless nickel plated
9	Piston seal	NBR	
10	Rod seal	NBR	
11	Tube gasket	NBR	

Repair Parts: Standard Seal Kit for Double Acting, Single Rod

Bore size	Kit no.	Remarks
056 (9/16")	NCQ8B056-PS	Piston seal, rod seal, and tube gasket are included.
075 (3/4")	NCQ8B075-PS	
106 (1-1/16")	NCQ8B106-PS	
150 (1-1/2")	NCQ8B150-PS	
200 (2")	NCQ8B200-PS	
250 (2-1/2")	NCQ8B250-PS	

Repair Parts: -XB6 Seal Kit for Double Acting, Single Rod

Bore size	Kit no.	Remarks
056 (9/16")	NCQ8B056-XB6-PS	Piston seal, rod seal, and tube gasket are included.
075 (3/4")	NCQ8B075-XB6-PS	
106 (1-1/16")	NCQ8B106-XB6-PS	
150 (1-1/2")	NCQ8B150-XB6-PS	
200 (2")	NCQ8B200-XB6-PS	
250 (2-1/2")	NCQ8B250-XB6-PS	

With auto switch

Here is the typical, cross-sectional construction. For details for each model, refer to the instruction manual.

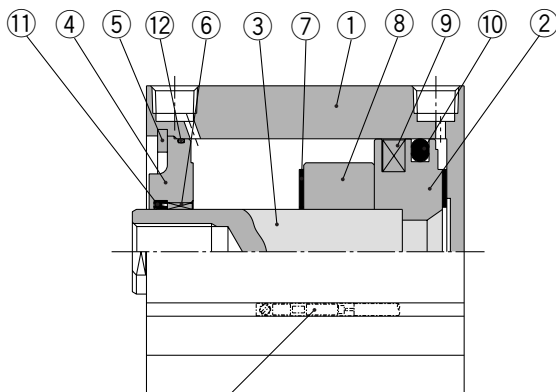

Auto switch

Parts List

No.	Description	Material	Remarks
1	Cylinder tube	Aluminum alloy	Hard anodized
2	Piston	Aluminum alloy	Chromated
3	Piston rod	Stainless steel	056 to 106
		Carbon steel	150 to 250 Hard chrome plated
4	Collar	Aluminum alloy	Anodized
5	Snap ring	Carbon tool steel	Phosphate coated
6	Bushing	Phosphor bronze alloy	200 and 250 only
7	Rubber bumper	NBR	Use for with rubber bumper only
8	Spacer	Aluminum alloy	Chromated, Use for standard type only
9	Magnet	—	
10	Piston seal	NBR	
11	Rod seal	NBR	
12	Tube gasket	NBR	

Repair Parts: Seal Kit for Double Acting, Single Rod

The part number will be the same as the one without auto switches.

Compact Cylinder Double Acting, Single Rod **Series NCQ8**

Dimensions/NCQ8B056 to 250 (Refer to page 44 for both ends tapped and male thread dimensions.)

056 (9/16")

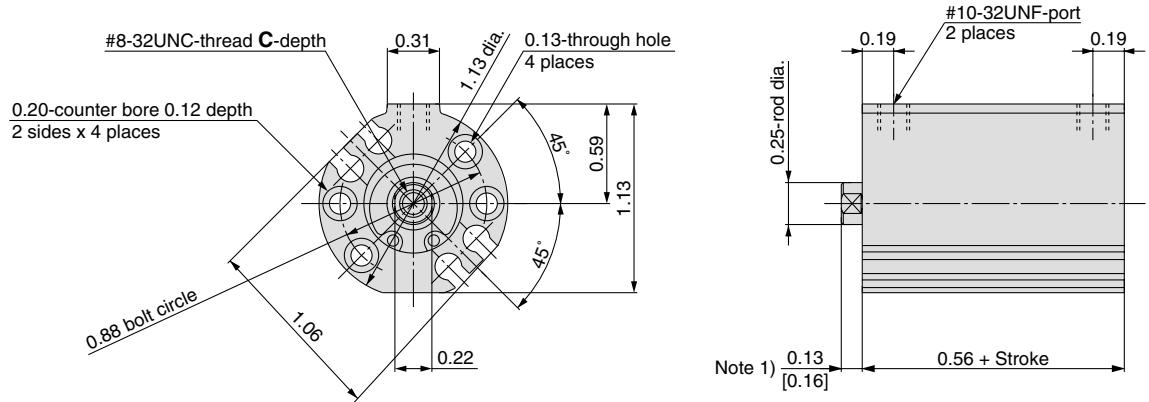

(Inch)	
Symbol	C
Stroke	
1/8"	0.36
1/4" to 4"	0.46

Note 1) According to the rubber bumper type, its stroke is reduced by 0.06" and the projection of a piston rod is 0.16".

075 (3/4"), 106 (1-1/16"), 150 (1-1/2"), 200 (2"), 250 (2-1/2")

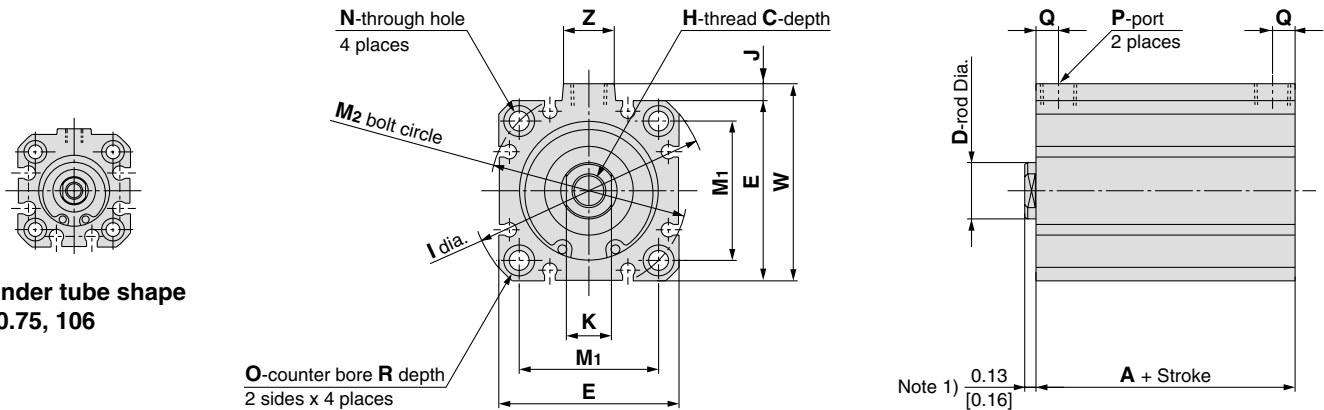

**Cylinder tube shape
for 0.75, 106**

		(Inch)																		
Bore	Symbol	A	C			D	E	H	I	J	K	M ₁	M ₂	N	O	P	Q	R	W	Z
			1/8"st	1/4"st	3/8" to 4"st															
075 (3/4")		0.56	0.36	0.46	0.31	1.25	#10-32UNF	1.56	0.06	0.25	0.86	1.22	0.15	0.25	#10-32UNF	0.19	0.15	1.31	0.38	
106 (1-1/16")		0.88	0.52	0.70	0.50	1.56	5/16-24UNF	2.03	0.16	0.44	1.19	1.69	0.15	0.25	NPT1/8	0.25	0.15	1.72	0.56	
150 (1-1/2")		0.88	0.50	0.70	0.63	2.00	3/8-24UNF	2.63	0.19	0.50	1.55	2.19	0.22	0.34	NPT1/8	0.25	0.20	2.19	0.56	
200 (2")		0.94	0.44	0.70	0.75	2.53	1/2-20UNF	3.13	0.20	0.63	1.90	2.69	0.22	0.34	NPT1/8	0.25	0.20	2.73	0.56	
250 (2-1/2")		1.19	0.44	0.70	0.75	2.84	1/2-20UNF	3.75	0.39	0.63	2.30	3.25	0.28	0.41	NPT1/4	0.33	0.26	3.23	0.69	

Note 1) According to the rubber bumper type, its stroke is reduced by 0.06" and the projection of a piston rod is 0.16".

Series NCQ8

Dimensions/NCQ8B056 to 250 (Refer to page 44 for both ends tapped and male thread dimensions.)

056 (9/16")

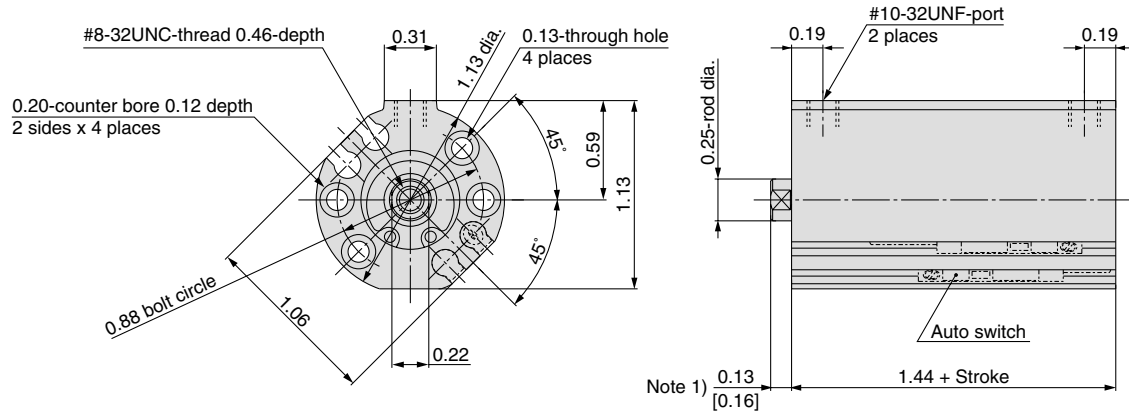

Note 1) According to the rubber bumper type, its stroke is reduced by 0.06" and the projection of a piston rod is 0.16.

075 (3/4"), 106 (1-1/16"), 150 (1-1/2"), 200 (2"), 250 (2-1/2")

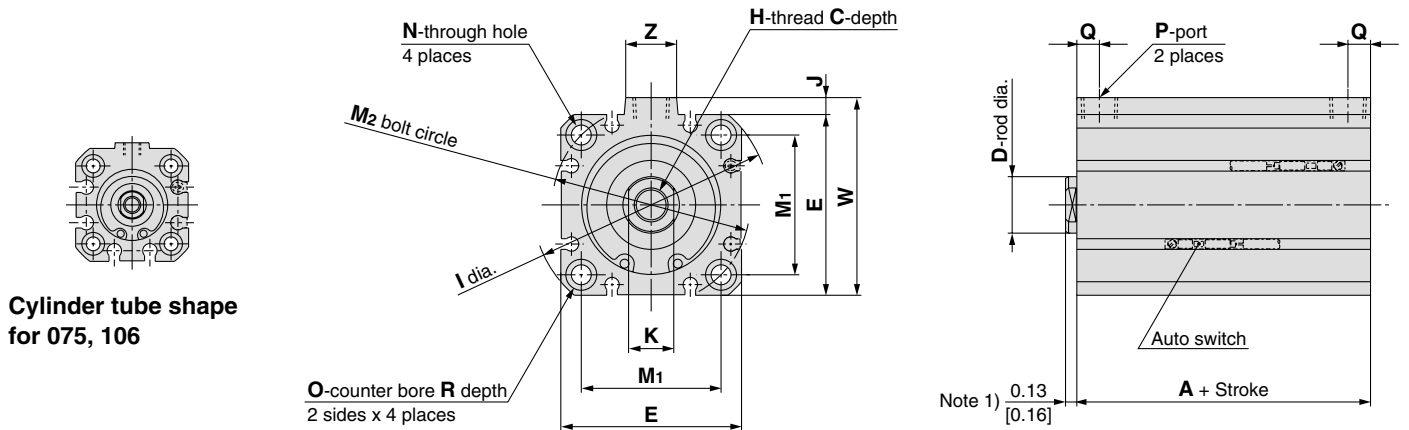

Cylinder tube shape for 075, 106

(Inch)

Symbol	A	C	D	E	H	I	J	K	M ₁	M ₂	N	O	P	Q	R	W	Z
075 (3/4")	1.44	0.46	0.31	1.25	#10-32UNF	1.56	0.06	0.25	0.86	1.22	0.15	0.25	#10-32UNF	0.19	0.15	1.31	0.38
106 (1-1/16")	1.75	0.70	0.50	1.56	5/16-24UNF	2.03	0.16	0.44	1.19	1.69	0.15	0.25	NPT1/8	0.25	0.15	1.72	0.56
150 (1-1/2")	1.75	0.70	0.63	2.00	3/8-24UNF	2.63	0.19	0.50	1.55	2.19	0.22	0.34	NPT1/8	0.25	0.20	2.19	0.56
200 (2")	1.81	0.70	0.75	2.53	1/2-20UNF	3.13	0.20	0.63	1.90	2.69	0.22	0.34	NPT1/8	0.25	0.20	2.73	0.56
250 (2-1/2")	2.06	0.70	0.75	2.84	1/2-20UNF	3.75	0.39	0.63	2.30	3.25	0.28	0.41	NPT1/4	0.33	0.26	3.23	0.69

Note 1) According to the rubber bumper type, its stroke is reduced by 0.06" and the projection of a piston rod is 0.16".

Compact Cylinder Double Acting, Single Rod **Series NCQ8**

Dimensions/NCQ8BZ056 to 250 (Refer to page 44 for both ends tapped and male thread dimensions.)

056 (9/16")

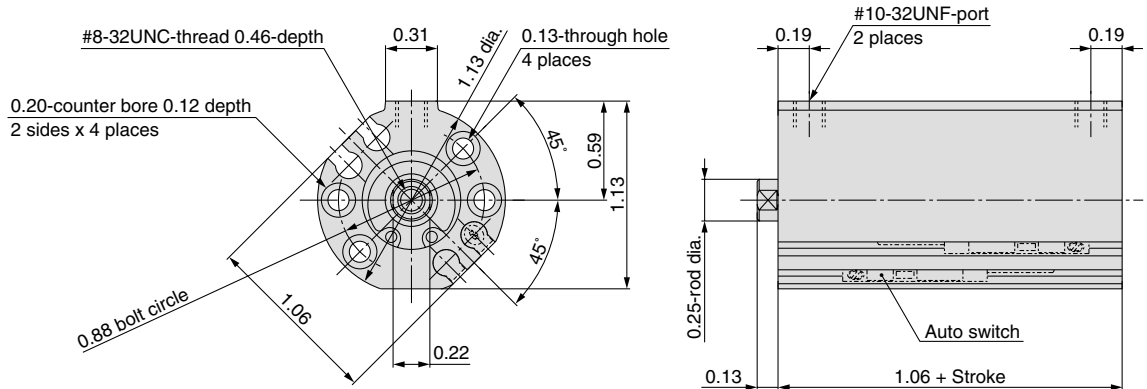

075 (3/4"), 106 (1-1/16"), 150 (1-1/2"), 200 (2"), 250 (2-1/2")

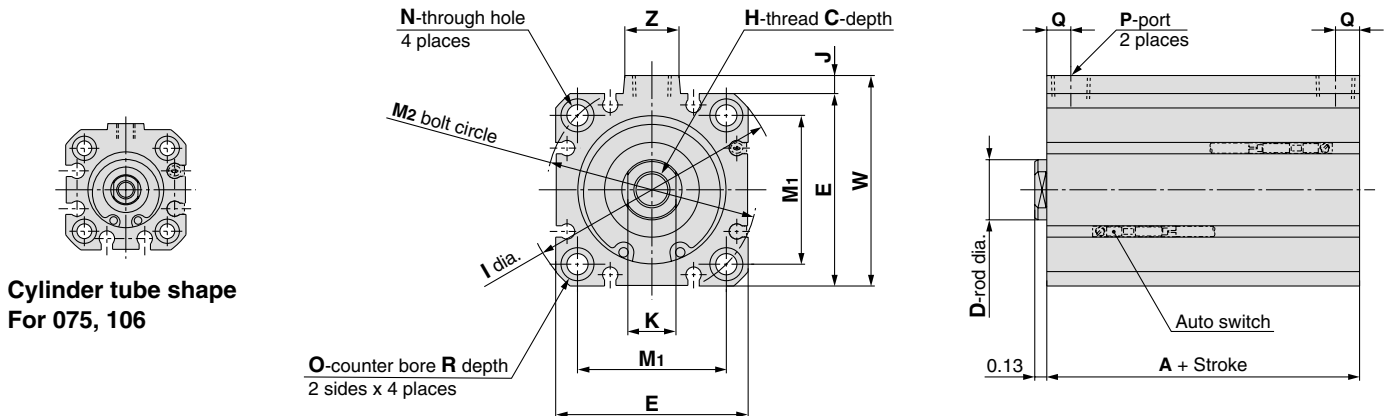

(Inch)

Symbol Bore	A	C		D	E	H	I	J	K	M ₁	M ₂	N	O	P	Q	R	W	Z
		1/4"st	3/8" to 4"st															
075 (3/4")	1.06	0.46	0.31	1.25	#10-32UNF	1.56	0.06	0.25	0.86	1.22	0.15	0.25	#10-32UNF	0.19	0.15	1.31	0.38	
106 (1-1/16")	1.25	0.52	0.70	0.50	1.56	5/16-24UNF	2.03	0.16	0.44	1.19	1.69	0.15	0.25	NPT1/8	0.25	0.15	1.72	0.56
150 (1-1/2")	1.25	0.50	0.70	0.63	2.00	3/8-24UNF	2.63	0.19	0.50	1.55	2.19	0.22	0.34	NPT1/8	0.25	0.20	2.19	0.56
200 (2")	1.19	0.70	0.75	2.53	1/2-20UNF	3.13	0.20	0.63	1.90	2.69	0.22	0.34	NPT1/8	0.25	0.20	2.73	0.56	
250 (2-1/2")	1.44	0.70	0.75	2.84	1/2-20UNF	3.75	0.39	0.63	2.30	3.25	0.28	0.41	NPT1/4	0.33	0.26	3.23	0.69	

Series NCQ8

Dimensions/NC(D)Q8□(Z)

Rear clevis / NC(D)Q8C(Z)

056 (9/16")

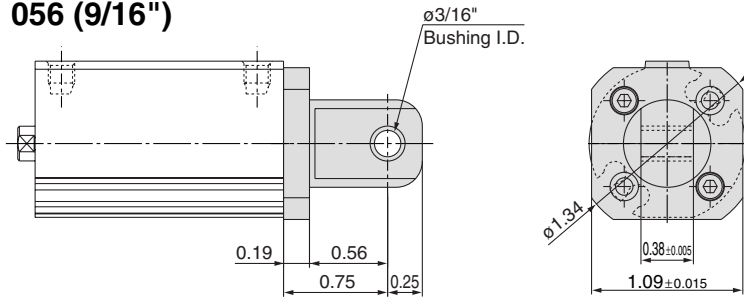

075 (3/4"), 106 (1-1/16"), 150 (1-1/2"), 200 (2"), 250 (2-1/2")

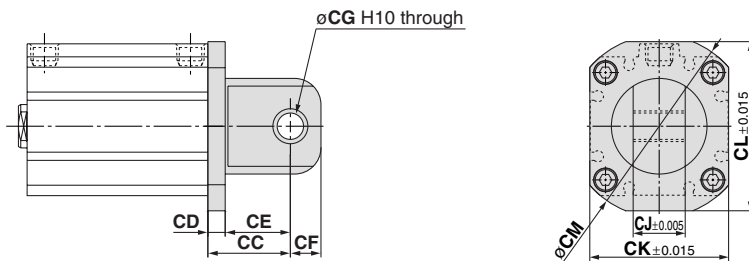

(Inch)

Symbol	CC	CD	CE	CF	CG	CJ
Bore						
075 (3/4")	0.75	0.19	0.56	0.25	3/16	0.38
106 (1-1/16")	0.81	0.25	0.56	0.25	3/16	0.38
150 (1-1/2")	1.19	0.25	0.94	0.44	3/8	0.75
200 (2")	1.25	0.31	0.94	0.44	3/8	0.75
250 (2-1/2")	1.31	0.38	0.93	0.44	3/8	0.75

Symbol	CK	CL	CM
Bore			
075 (3/4")	1.25	1.47	1.56
106 (1-1/16")	1.56	1.94	2.03
150 (1-1/2")	2.00	2.44	2.62
200 (2")	1.90	3.00	3.13
250 (2-1/2")	2.30	3.62	3.74

Front screw clearance hole / NC(D)Q8E(Z)

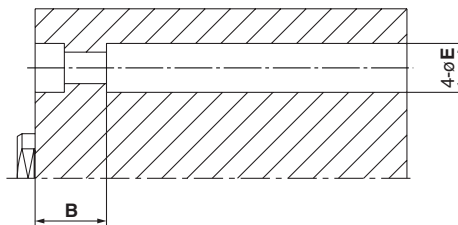

(Inch)

Symbol	B	E
Bore		
056 (9/16")	0.34	0.20
075 (3/4")	0.34	0.25
106 (1-1/16")	0.50	0.25
150 (1-1/2")	0.50	0.34
200 (2")	0.53	0.34
250 (2-1/2")	0.66	0.41

Rear screw clearance hole / NC(D)Q8M(Z)

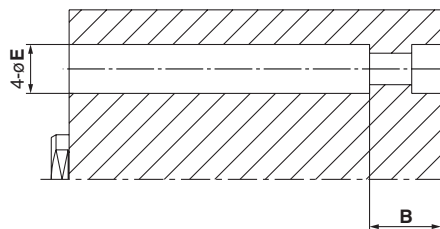

(Inch)

Symbol	B	E
Bore		
056 (9/16")	0.34	0.20
075 (3/4")	0.34	0.25
106 (1-1/16")	0.50	0.25
150 (1-1/2")	0.50	0.34
200 (2")	0.53	0.34
250 (2-1/2")	0.66	0.41

Through screw clearance hole / NC(D)Q8N(Z)

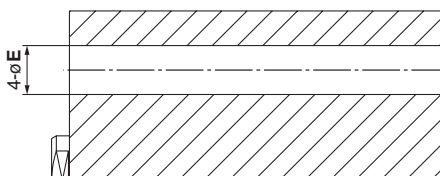

(Inch)

Symbol	E
Bore	
056 (9/16")	0.20
075 (3/4")	0.25
106 (1-1/16")	0.25
150 (1-1/2")	0.34
200 (2")	0.34
250 (2-1/2")	0.41

Compact Cylinder Double Acting, Double Rod Series **NCQ8W**

Bore size: 056 (9/16"), 075 (3/4"), 106 (1-1/16"), 150 (1-1/2"), 200 (2"), 250 (2-1/2")

How to Order

Without auto switch

NCQ8W

B **056** **025**

X-Option

Nil	Standard
XB6 <small>Note 3)</small>	High temp.
XC4	With scraper

Note 3) XB6: Not available with magnet.

*For detailed made to order specifications, refer to page 46.

With auto switch

NCDQ8W

B **056** **025** **M9B** **S**

Number of auto switches

Nil	2 pcs.
S	1 pc.
n	"n" pcs.

Auto switch type

Nil	Without auto switch (Built-in magnet cylinder)
-----	--

*Refer to the table below for auto switch model numbers.

*Auto switches are shipped together, (but not assembled).

Built-in magnet

Double rod

Mounting

B	Through-hole
A	Both ends tapped
E	Front screw clearance hole
N	Through screw clearance hole

Nominal bore size

056	9/16"
075	3/4"
106	1-1/16"
150	1-1/2"
200	2"
250	2 1/2"

Cylinder stroke (inch)

Symbol	Stroke	Symbol	Stroke	Symbol	Stroke	Symbol	Stroke
012	1/8"	062	5/8"	125	1-1/4"	250	2-1/2"
025 <small>Note 1)</small>	1/4"	075	3/4"	150	1-1/2"	300	3"
037	3/8"	087	7/8"	175	1-3/4"	350	3-1/2"
050	1/2"	100	1"	200	2"	400	4"

Note 1) With switch is available on strokes 025 (1/4") and greater.

Body option

Nil	Standard (Female rod end)
C <small>Note 2)</small>	Rubber bumper
M	Male rod end

Note 2) Stroke will be reduced by 0.06" for rubber bumper type.

*Combination of body options(CM) is available.

Applicable Auto Switches

Type	Special function	Electrical entry	Indicator light	Wiring (output)	Load voltage			Auto switch model		Lead wire length (in)*			Applicable load													
					DC		AC	Perpendicular	In-line	20 (0.5m) (Nil)	118 (3m) (L)	197 (5m) (Z)														
					—	5 V	—	A96V	A96	●	●	—														
Reed switch	—	Grommet	Yes	3-wire (NPN equiv.)	—	5 V	—	A90V	A90	●	●	—	IC circuit	—												
															No	2-wire	24 V	5 V, 12 V	100 V	A93V	A93	●	●	—	IC circuit	Relay, PLC
Solid state switch	—	Grommet	—	3-wire (NPN)	24 V	5 V, 12 V	—	M9NV	M9N	●	●	○	IC circuit	Relay, PLC												
				3-wire (PNP)				M9PV	M9P	●	●	○														
				2-wire				M9BV	M9B	●	●	○														
				Yes				3-wire (NPN)	F9NWV	F9NW	●	●			○	IC circuit										
								3-wire (PNP)	F9PWV	F9PW	●	●			○											
								2-wire	F9BWV	F9BW	●	●			○											
				Water resistant (2-color display)				—	F9BA	—	●	○			—											

*Lead wire length symbols: 20in (0.5 m)..... Nil (Example) M9N
 118in (3 m)..... L M9NL
 197in (5 m)..... Z M9NZ

*Solid state switches marked with a "○" symbol are produced upon receipt of order.

Series NCQ8W



JIS Symbol
Double acting,
Double rod

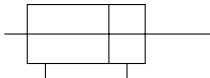

Specifications

Bore size	056 (9/16")	075 (3/4")	106 (1-1/16")	150 (1-1/2")	200 (2")	250 (2-1/2")
Piping size	#10-32UNF	#10-32UNF	NPT1/8	NPT1/8	NPT1/8	NPT1/4
Type	Pneumatic (Non-lube)					
Action	Double acting, Double rod					
Fluid	Air					
Proof pressure	300PSI (2.1MPa)					
Maximum operating pressure	200PSI (1.4MPa)					
Minimum operating pressure	056		11PSI (0.07MPa)			
	075 to 250		8PSI (0.05MPa)			
Ambient and fluid temperature	Without auto switch		15 to 150°F (-10 to 65°C) (No freezing)			
	With switch		15 to 140°F (-10 to 60°C) (No freezing)			
Cushion	Rubber bumper					
Rod end thread	Female thread					
Rod end thread tolerance	Class 2					
Stroke tolerance	0 to +0.04 in (+1.0mm)					
Mounting	Through-hole (B), Both ends tapped (A), SCH (E, M)					
Piston speed	2 to 20in/sec (50 to 500mm/s)					

Applicable Stroke

Unit: inch

Bore size	Standard stroke
056 (9/16")	012 (1/8"), 025 (1/4"), 037 (3/8")
075 (3/4")	050 (1/2"), 062 (5/8"), 075 (3/4")
106 (1-1/16")	087 (7/8"), 100 (1"), 125 (1-1/4")
150 (1-1/2")	150 (1-1/2"), 175 (1-3/4"), 200 (2")
200 (2")	250 (2-1/2"), 300 (3")
250 (2-1/2")	350 (3-1/2"), 400 (4")

* With switch is available on strokes 025 (1/4") and greater.

Theoretical Output Table

Unit: lbs

Bore size (in)	Operating pressure/PSI (MPa)			
	45 (0.3)	75 (0.5)	145 (1.0)	200 (1.4)
056 (9/16")	8.87	14.6	28.6	39.2
075 (3/4")	16.4	27.0	52.9	72.5
106 (1-1/16")	30.8	50.8	99.5	136
150 (1-1/2")	65.7	108	212	290
200 (2")	121	200	391	536
250 (2-1/2")	201	330	648	888

Weights

Double Acting, Double Rod, Without Switch

(OZ)

Model \ Stroke	012 (1/8")	025 (1/4")	037 (3/8")	050 (1/2")	062 (5/8")	075 (3/4")	087 (7/8")	100 (1")	125 (1-1/4")	0150 (1-1/2")	175 (1-3/4")	200 (2")	250 (2-1/2")	300 (3")	350 (3-1/2")	400 (4")
NCQ8W□056-□	1.33	1.39	1.46	1.52	1.69	1.86	2.03	2.20	2.54	2.88	3.21	3.55	4.23	4.91	5.58	6.26
NCQ8W□075-□	1.92	2.04	2.15	2.26	2.52	2.77	3.02	3.28	3.79	4.29	4.80	5.31	6.33	7.34	8.36	9.37
NCQ8W□106-□	3.71	4.14	4.56	4.99	5.42	5.84	6.34	6.84	7.83	8.83	9.82	10.9	12.8	14.8	16.8	18.8
NCQ8W□150-□	7.01	7.80	8.50	9.21	9.91	9.63	10.4	11.1	12.5	13.9	15.4	16.8	19.6	22.4	25.3	28.1
NCQ8W□200-□	12.9	13.7	14.5	15.4	16.2	17.0	16.5	17.3	19.0	20.7	22.3	24.0	27.3	30.6	33.9	37.2
NCQ8W□250-□	18.7	19.6	20.5	21.3	22.2	21.0	21.9	22.8	24.6	26.3	28.1	29.9	33.4	37.0	40.6	44.1

Double Acting, Double Rod, With Switch

(OZ)

Model \ Stroke	012 (1/8")	025 (1/4")	037 (3/8")	050 (1/2")	062 (5/8")	075 (3/4")	087 (7/8")	100 (1")	125 (1-1/4")	150 (1-1/2")	175 (1-3/4")	200 (2")	250 (2-1/2")	300 (3")	350 (3-1/2")	400 (4")
NCDQ8W□056-□	—	2.70	2.76	2.72	2.89	3.06	3.23	3.40	3.74	4.08	4.41	4.75	5.43	6.11	6.78	7.46
NCDQ8W□075-□	—	4.22	4.34	4.24	4.49	4.75	5.00	5.25	5.76	6.27	6.78	7.28	8.30	9.32	10.4	11.4
NCDQ8W□106-□	—	8.19	8.62	9.04	9.47	9.19	9.69	10.2	11.2	12.2	13.2	14.2	16.2	18.2	20.2	22.2
NCDQ8W□150-□	—	17.3	18.0	18.7	19.4	15.5	16.2	16.9	18.3	19.8	21.2	22.6	25.4	28.3	31.1	33.9
NCDQ8W□200-□	—	33.3	34.2	35.0	35.8	36.6	24.7	25.5	27.2	28.8	30.5	32.2	35.5	38.8	42.1	45.4
NCDQ8W□250-□	—	50.0	50.9	51.7	52.6	31.2	32.0	32.9	34.7	36.5	38.3	40.0	43.6	47.2	50.7	54.3

Compact Cylinder Double Acting, Double Rod *Series NCQ8W*

Option Weights

Unit: OZ

Bore size	Clevis
056 (9/16")	0.71
075 (3/4")	0.93
106 (1-1/16")	1.64
150 (1-1/2")	4.16
200 (2")	6.04
250 (2-1/2")	8.74

Allowable Kinetic Energy

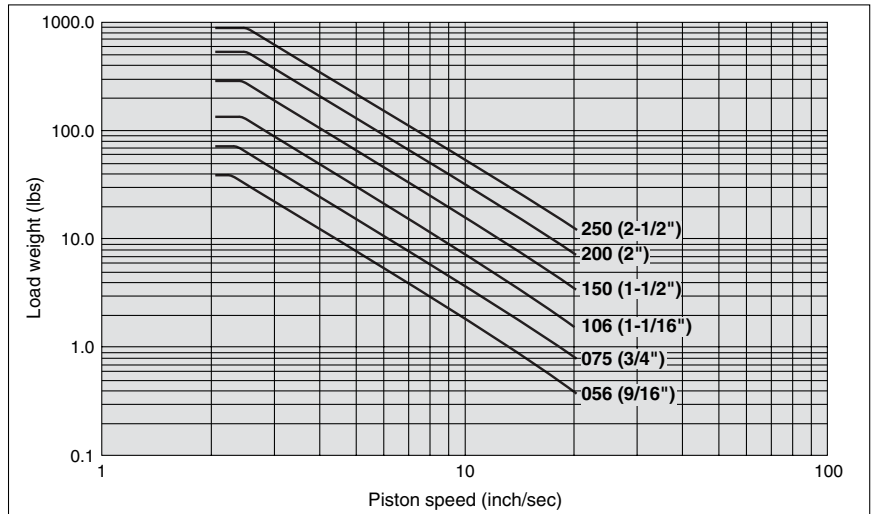

Series NCQ8W

Mounting Bolt

Mounting method: Mounting bolt for through-hole style of NCQ8WB is available as an option.

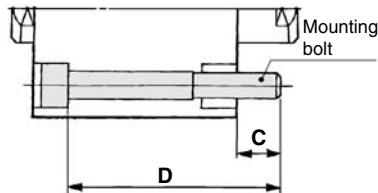

Mounting Bolt Size for NCQ8WB056 to 250-□ (Without Auto Switch)

(Inch)

Model	C	D	Bolt size
NCQ8WB056-012	0.18	7/8	#4-40UNC- 7/8
025		1	1
037		1-1/8	1-1/8
050		1-1/4	1-1/4
062		1-3/8	1-3/8
075		1-1/2	1-1/2
087		1-5/8	1-5/8
100		1-3/4	1-3/4
125		2	2
150		2-1/4	2-1/4
175		2-1/2	2-1/2
200		2-3/4	2-3/4
250		3-1/4	3-1/4
300		3-3/4	3-3/4
350		4-1/4	4-1/4
400		4 3/4	4 3/4
NCQ8WB075-012	0.21	7/8	#6-32UNC- 7/8
025		1	1
037		1-1/8	1-1/8
050		1-1/4	1-1/4
062		1-3/8	1-3/8
075		1-1/2	1-1/2
087		1-5/8	1-5/8
100		1-3/4	1-3/4
125		2	2
150		2-1/4	2-1/4
175		2-1/2	2-1/2
200		2-3/4	2-3/4
250		3-1/4	3-1/4
300		3-3/4	3-3/4
350		4-1/4	4-1/4
400		4 3/4	4-3/4
NCQ8WB106-012	0.21	1-1/8	#6-32UNC- 1-1/8
025		1-1/4	1-1/4
037		1-3/8	1-3/8
050		1-1/2	1-1/2
062		1-5/8	1-5/8
075		1-3/4	1-3/4
087		1-7/8	1-7/8
100		2	2
125		2-1/4	2-1/4
150		2-1/2	2-1/2
175		2-3/4	2-3/4
200		3	3
250		3-1/2	3-1/2
300		4	4
350		4-1/2	4-1/2
400		5	5

Model	C	D	Bolt size
NCQW8B150-012	0.33	1-1/4	#10-24UNC- 1-1/4
025		1-3/8	1-3/8
037		1-1/2	1-1/2
050		1-5/8	1-5/8
062		1-3/4	1-3/4
075		1-7/8	1-7/8
087		2	2
100		2-1/8	2-1/8
125		2-3/8	2-3/8
150		2-5/8	2-5/8
175		2-7/8	2-7/8
200		3-1/8	3-1/8
250		3-5/8	3-5/8
300		4-1/8	4-1/8
350		4-5/8	4-5/8
400		5-1/8	5-1/8
NCQ8WB200-012	0.39	1-3/8	#10-24UNC- 1-3/8
025		1-1/2	1-1/2
037		1-5/8	1-5/8
050		1-3/4	1-3/4
062		1-7/8	1-7/8
075		2	2
087		2-1/8	2-1/8
100		2-1/4	2-1/4
125		2-1/2	2-1/2
150		2-3/4	2-3/4
175		3	3
200		3-1/4	3-1/4
250		3-3/4	3-3/4
300		4-1/4	4-1/4
350		4-3/4	4-3/4
400		5-1/4	5-1/4
NCQW8B250-012	0.45	1-5/8	1/4-20UNC- 1-5/8
025		1-3/4	1-3/4
037		1-7/8	1-7/8
050		2	2
062		2-1/8	2-1/8
075		2-1/4	2-1/4
087		2-3/8	2-3/8
100		2-1/2	2-1/2
125		2-3/4	2-3/4
150		3	3
175		3-1/4	3-1/4
200		3-1/2	3 1/2
250		4	4
300		4-1/2	4-1/2
350		5	5
400		5-1/2	5-1/2

Compact Cylinder Double Acting, Double Rod *Series NCQ8W*

Mounting Bolt

Mounting method: Mounting bolt for through-hole style of NCQ8WB is available as an option.

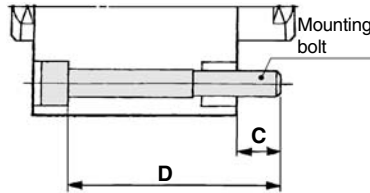

Mounting Bolt Size for NCDQ8WB056 to 250-□ (With Auto Switch)

(Inch)

Model	C	D	Bolt size
NCDQ8WB056-025	0.18	1-7/8	#4-40UNC- 1-7/8
037		2	2
050		2-1/8	2-1/8
062		2-1/4	2-1/4
075		2-3/8	2-3/8
087		2-1/2	2-1/2
100		2-5/8	2-5/8
125		2-7/8	2-7/8
150		3-1/8	3-1/8
175		3-3/8	3-3/8
200		3-5/8	3-5/8
250		4-1/8	4-1/8
300		4-5/8	4-5/8
350		5-1/8	5-1/8
400		5-5/8	5-5/8
NCDQ8WB075-025		0.21	1-7/8
037	2		2
050	2-1/8		2-1/8
062	2-1/4		2-1/4
075	2-3/8		2-3/8
087	2-1/2		2-1/2
100	2-5/8		2-5/8
125	2-7/8		2-7/8
150	3-1/8		3-1/8
175	3-3/8		3-3/8
200	3-5/8		3-5/8
250	4-1/8		4-1/8
300	4-5/8		4-5/8
350	5-1/8		5-1/8
400	5-5/8		5-5/8
NCDQ8WB106-025	0.21		2-1/8
037		2-1/4	2-1/4
050		2-3/8	2-3/8
062		2-1/2	2-1/2
075		2-5/8	2-5/8
087		2-3/4	2-3/4
100		2-7/8	2-7/8
125		3-1/8	3-1/8
150		3-3/8	3-3/8
175		3-5/8	3-5/8
200		3-7/8	3-7/8
250		4-3/8	4-3/8
300		4-7/8	4-7/8
350		5-3/8	5-3/8
400		5-7/8	5-7/8

Model	C	D	Bolt size
NCDQ8BW150-025	0.33	2-1/4	#10-24UNC- 2-1/4
037		2-3/8	2-3/8
050		2-1/2	2-1/2
062		2-5/8	2-5/8
075		2-3/4	2-3/4
087		2-7/8	2-7/8
100		3	3
125		3-1/4	3-1/4
150		3-1/2	3-1/2
175		3-3/4	3-3/4
200		4	4
250		4-1/2	4-1/2
300		5	5
350		5-1/2	5-1/2
400		6	6
NCDQ8WB200-025		0.39	2-3/8
037	2-1/2		2-1/2
050	2-5/8		2-5/8
062	2-3/4		2-3/4
075	2-7/8		2-7/8
087	3		3
100	3-1/8		3-1/8
125	3-3/8		3-3/8
150	3-5/8		3-5/8
175	3-7/8		3-7/8
200	4-1/8		4-1/8
250	4-5/8		4-5/8
300	5-1/8		5-1/8
350	5-5/8		5-5/8
400	6-1/8		6-1/8
NCDQ8WB250-025	0.45		2-5/8
037		2-3/4	2-3/4
050		2-7/8	2-7/8
062		3	3
075		3-1/8	3-1/8
087		3-1/4	3-1/4
100		3-3/8	3-3/8
125		3-5/8	3-5/8
150		3-7/8	3-7/8
175		4-1/8	4-1/8
200		4-3/8	4-3/8
250		4-7/8	4-7/8
300		5-3/8	5-3/8
350		5-7/8	5-7/8
400		6-3/8	6-3/8

Series NCQ8W

Construction

Without auto switch

Here is the typical, cross-sectional construction. For details for each model, refer to the instruction manual.

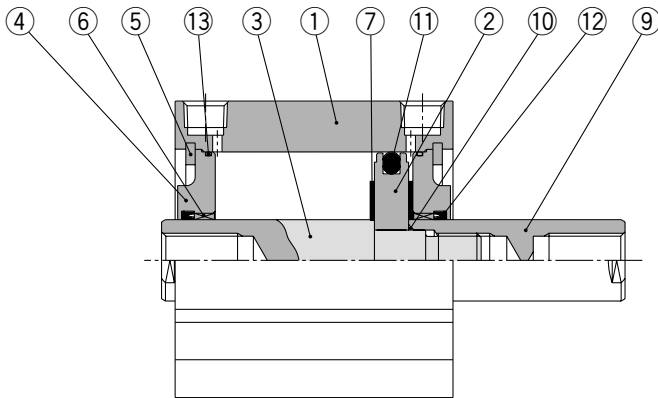

Parts List

No.	Description	Material	Remarks
1	Cylinder tube	Aluminum alloy	Hard anodized
2	Piston	Aluminum alloy	Chromated
3	Piston rod A	Stainless steel	056 to 106
		Carbon steel	150 to 250 Hard chrome plated
4	Collar	Aluminum alloy	Anodized
5	Snap ring	Carbon tool steel	Phosphate coated
6	Bushing	Phosphor bronze alloy	200 and 250 only
7	Rubber bumper	NBR	Use for w/ rubber bumper only.

Repair Parts: Standard Seal Kit for Double Acting, Double Rod

Bore size	Kit no.	Remarks
056 (9/16")	NCQ8WB056-PS	Piston seal, rod seal and tube gasket are included.
075 (3/4")	NCQ8WB075-PS	
106 (1-1/16")	NCQ8WB106-PS	
150 (1-1/2")	NCQ8WB150-PS	
200 (2")	NCQ8WB200-PS	
250 (2-1/2")	NCQ8WB250-PS	

With auto switch

Here is the typical, cross-sectional construction. For details for each model, refer to the instruction manual.

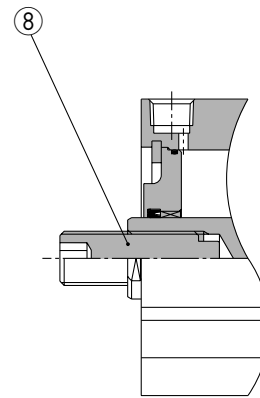
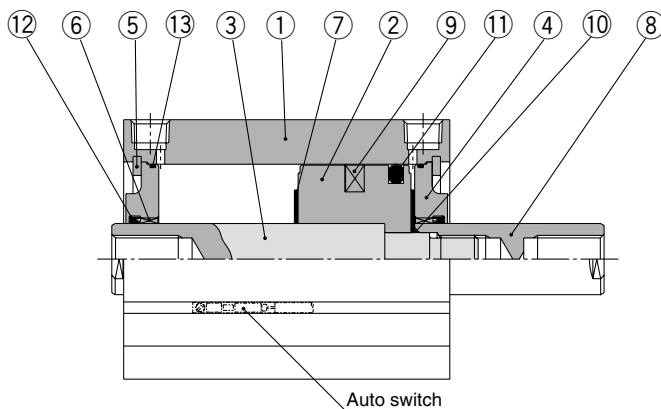

Male thread

No.	Description	Material	Remarks
8	Stud	Steel alloy	Electroless nickel plated
		Stainless steel	056 to 106
9	Piston rod B	Carbon steel	150 to 250 Hard chrome plated
		NBR	150 and more only
10	Piston gasket	NBR	
11	Piston seal	NBR	
12	Rod seal	NBR	
13	Tube gasket	NBR	

Repair Parts: -XB6 Seal Kit for Double Acting, Double Rod

Bore size	Kit no.	Remarks
056 (9/16")	NCQ8WB056-XB6-PS	Piston seal, rod seal, and tube gasket are included.
075 (3/4")	NCQ8WB075-XB6-PS	
106 (1-1/16")	NCQ8WB106-XB6-PS	
150 (1-1/2")	NCQ8WB150-XB6-PS	
200 (2")	NCQ8WB200-XB6-PS	
250 (2-1/2")	NCQ8WB250-XB6-PS	

Parts List

No.	Description	Material	Remarks
1	Cylinder tube	Aluminum alloy	Hard anodized
2	Piston	Aluminum alloy	Chromated
3	Piston rod A	Stainless steel	056 to 106
		Carbon steel	150 to 250 Hard chrome plated
4	Collar	Aluminum alloy	Anodized
5	Snap ring	Carbon tool steel	Phosphate coated
6	Bushing	Phosphor bronze alloy	200 and 250 only
7	Rubber bumper	NBR	Use for with rubber bumper only.
8	Piston rod B	Stainless steel	056 to 106
		Carbon steel	150 to 250 Hard chrome plated
9	Magnet	—	
10	Piston gasket	NBR	150 and more only
11	Piston seal	NBR	
12	Rod seal	NBR	
13	Tube gasket	NBR	

Repair Parts: Seal Kit for Double Acting, Double Rod

The part number will be the same as the one without auto switches.

Compact Cylinder Double Acting, Double Rod *Series NCQ8W*

Dimensions/NCQ8WB056 to 250 (Refer to page 44 for both ends tapped and male thread dimensions.)

056 (9/16")

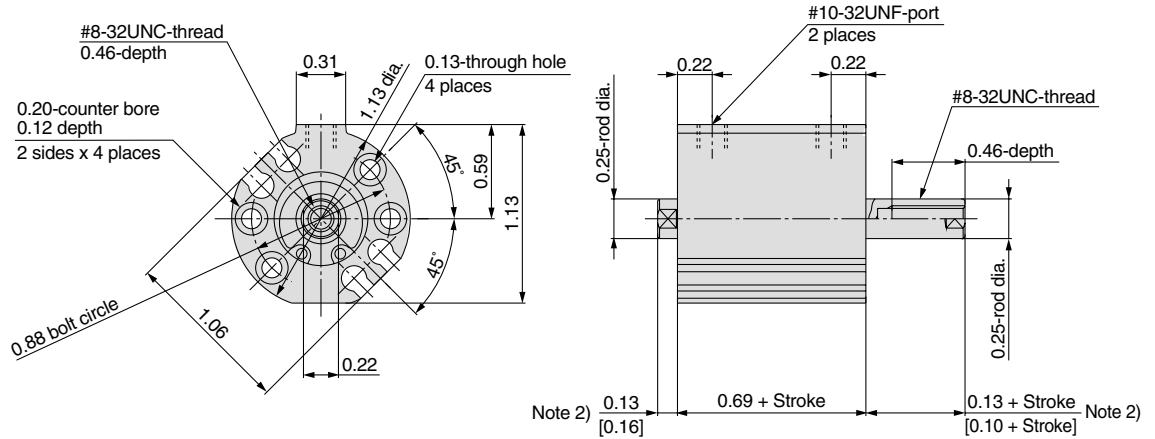

Note 1) Stroke will be reduced by 0.06" for rubber bumper type.

Note 2) According to the rubber bumper type, projection of piston rods will be [0.16] and [0.10 + STROKE] for sides.

056 (3/4"), 106 (1-1/16"), 150 (1-1/2"), 200 (2"), 250 (2-1/2")

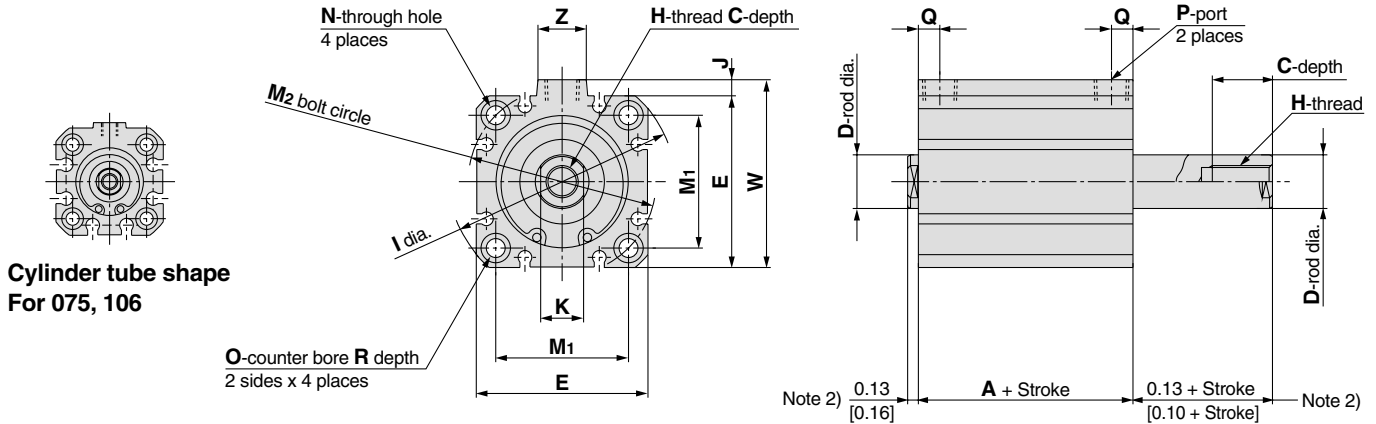

**Cylinder tube shape
For 075, 106**

O-counter bore R depth
2 sides x 4 places

Symbol	A	C	D	E	H	I	J	K	M ₁	M ₂	N	O	P	Q	R	W	Z
075 (3/4")	0.69	0.46	0.31	1.25	#10-32UNF	1.56	0.06	0.25	0.86	1.22	0.15	0.25	#10-32UNF	0.22	0.15	1.31	0.38
106 (1-1/16")	0.94	0.70	0.50	1.56	5/16-24UNF	2.03	0.16	0.44	1.19	1.69	0.15	0.25	NPT1/8	0.25	0.15	1.72	0.56
150 (1-1/2")	1.00	0.70	0.63	2.00	3/8-24UNF	2.63	0.19	0.50	1.55	2.19	0.22	0.34	NPT1/8	0.25	0.20	2.19	0.56
200 (2")	1.06	0.70	0.75	2.53	1/2-20UNF	3.13	0.20	0.63	1.90	2.69	0.22	0.34	NPT1/8	0.28	0.20	2.73	0.56
250 (2-1/2")	1.31	0.70	0.75	2.84	1/2-20UNF	3.75	0.39	0.63	2.30	3.25	0.28	0.41	NPT1/4	0.33	0.26	3.23	0.69

(Inch)

Note 1) Stroke will be reduced by 0.06" for rubber bumper type.

Note 2) According to the rubber bumper type, projection of piston rods will be [0.16] and [0.10 + Stroke] for sides.

Series NCQ8W

Dimensions/NCDQ8WB056 to 250 (Refer to page 44 for both ends tapped and male thread dimensions.)

056 (9/16")

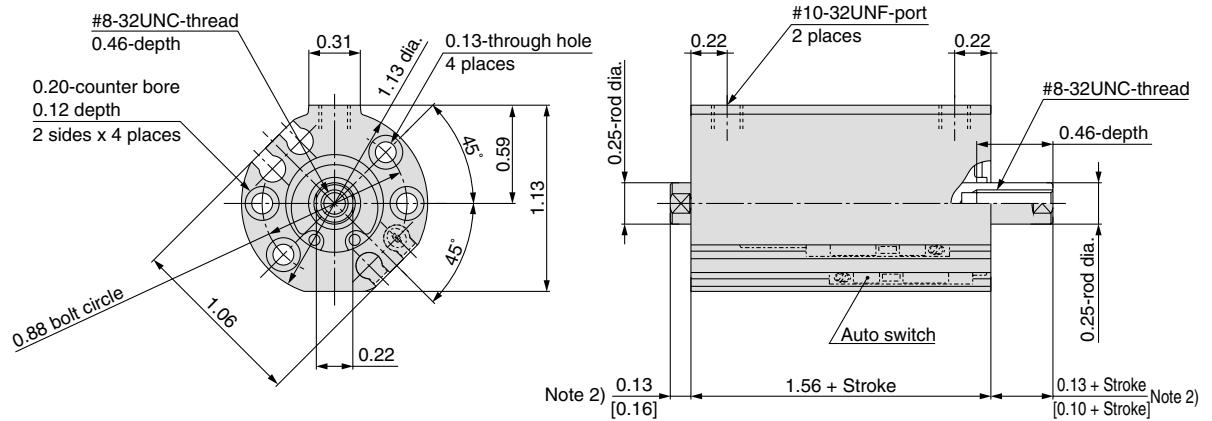

Note 1) Stroke will be reduced by 0.06" for rubber bumper type.
 Note 2) According to the rubber bumper type, projection of piston rods will be [0.16] and [0.10 + Stroke] for sides.

075 (3/4"), 106 (1-1/16"), 150 (1-1/2"), 200 (2"), 250 (2-1/2")

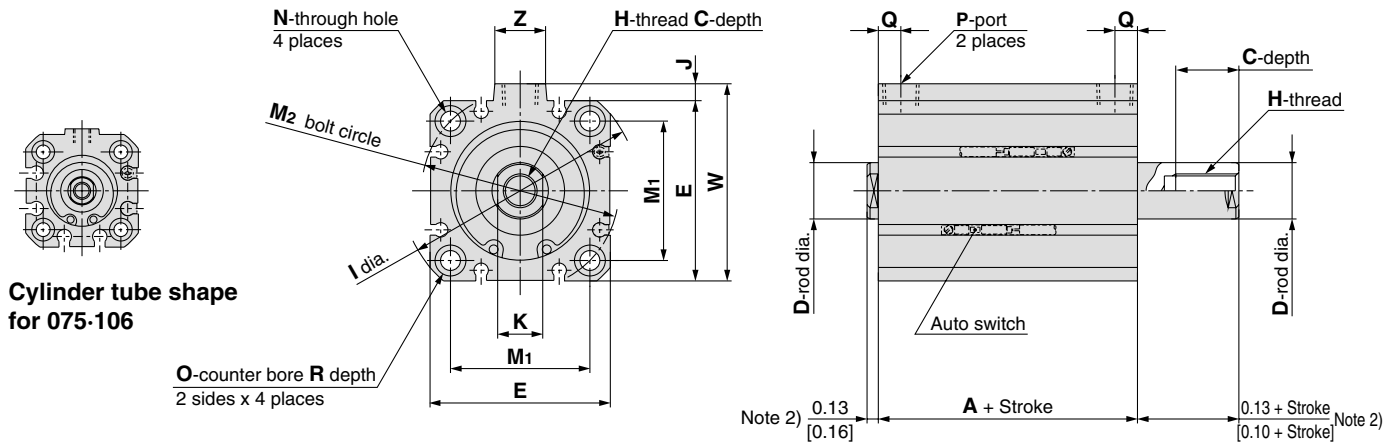

Cylinder tube shape for 075-106

Symbol Bore	(Inch)																
	A	C	D	E	H	I	J	K	M ₁	M ₂	N	O	P	Q	R	W	Z
075 (3/4")	1.56	0.46	0.31	1.25	#10-32UNF	1.56	0.06	0.25	0.86	1.22	0.15	0.25	#10-32UNF	0.22	0.15	1.31	0.38
106 (1-1/16")	1.81	0.70	0.50	1.56	5/16-24UNF	2.03	0.16	0.44	1.19	1.69	0.15	0.25	NPT1/8	0.25	0.15	1.72	0.56
150 (1-1/2")	1.88	0.70	0.63	2.00	3/8-24UNF	2.63	0.19	0.50	1.55	2.19	0.22	0.34	NPT1/8	0.25	0.20	2.19	0.56
200 (2")	1.94	0.70	0.75	2.53	1/2-20UNF	3.13	0.20	0.63	1.90	2.69	0.22	0.34	NPT1/8	0.28	0.20	2.73	0.56
250 (2-1/2")	2.19	0.70	0.75	2.84	1/2-20UNF	3.75	0.39	0.63	2.30	3.25	0.28	0.41	NPT1/4	0.33	0.26	3.23	0.69

Note 1) Stroke will be reduced by 0.06" for rubber bumper type.
 Note 2) According to the rubber bumper type, projection of piston rods will be [0.16] and [0.10 + Stroke] for sides.

Compact Cylinder Double Acting, Double Rod *Series NCQ8W*

Dimensions/NC(D)Q8W□

Front screw clearance hole / NC(D)Q8WE

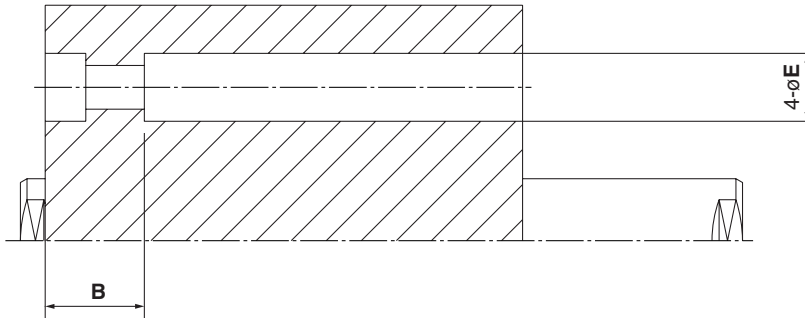

(Inch)

Symbol	B	E
Bore		
056 (9/16")	0.34	0.20
075 (3/4")	0.34	0.25
106 (1-1/16")	0.50	0.25
150 (1-1/2")	0.50	0.34
200 (2")	0.53	0.34
250 (2-1/2")	0.66	0.41

Through screw clearance hole / NC(D)Q8WN

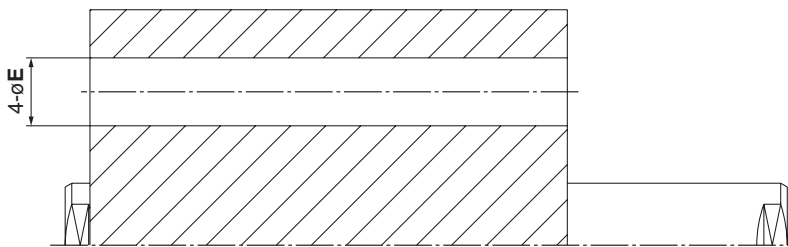

(Inch)

Symbol	E
Bore	
056 (9/16")	0.20
075 (3/4")	0.25
106 (1-1/16")	0.25
150 (1-1/2")	0.34
200 (2")	0.34
250 (2-1/2")	0.41

Compact Cylinder Single Acting, Single Rod Series **NCQ8**

Bore size: 056 (9/16"), 075 (3/4"), 106 (1-1/16"), 150 (1-1/2"), 200 (2"), 250 (2-1/2")

How to Order

Without auto switch NCQ8 **B** **056** **025** **S**

With auto switch NCDQ8 **B** **056** **025** **S** **M9B** **S**

Built-in magnet

Mounting

B	Through-hole
A	Both end tapped
C	Rear clevis
E	Front screw clearance hole
M	Rear screw clearance hole
N	Through screw clearance hole

Overall length type

Nil	Standard
Z	Super compact

Nominal bore size

056	9/16"
075	3/4"
106	1-1/16"
150	1-1/2"
200	2"
250	2-1/2"

Cylinder stroke (in)

Symbol	Stroke	Symbol	Stroke	Symbol	Stroke
012	1/8"	062	5/8"	125	1-1/4"
025 ^{Note 1)}	1/4"	075	3/4"	150	1-1/2"
037	3/8"	087	7/8"	175	1-3/4"
050	1/2"	100	1"	200	2"

Note 1) With switch is available on strokes 025 (1/4") and greater.

Number of auto switches

Nil	2 pcs.
S	1 pc.
n	"n" pcs.

Auto switch type

Nil	Without auto switch (Built-in magnet cylinder)
------------	--

*Refer to the table below for auto switch model numbers.
*Auto switches are shipped together, (but not assembled).

Body option

Nil	Standard (Female rod end)
M	Male rod end

Actuation

S	Single acting, Spring return
T	Single acting, Spring extend

Applicable Auto Switches

Type	Special function	Electrical entry	Indicator light	Wiring (output)	Load voltage			Auto switch model		Lead wire length (in)*			Applicable load	
					DC		AC	Perpendicular	In-line	20 (0.5m) (Nil)	118 (3m) (L)	197 (5m) (Z)		
					—	5 V	—							
Reed switch	—	Grommet	Yes	3-wire (NPN equiv.)	—	5 V	—	A96V	A96	●	●	—	IC circuit	—
				2-wire	24 V	5 V, 12 V	100 V	A90V	A90	●	●	—	IC circuit	Relay, PLC
					—	12 V	—	A93V	A93	●	●	—	—	
Solid state switch	—	Grommet	—	3-wire (NPN)	24 V	5 V, 12 V	—	M9NV	M9N	●	●	○	IC circuit	Relay, PLC
				3-wire (PNP)				M9PV	M9P	●	●	○	—	
				2-wire				M9BV	M9B	●	●	○	—	
		Diagnostic indication (2-color display)	Grommet	Yes	3-wire (NPN)	5 V, 12 V	F9NWV	F9NW	●	●	○	IC circuit		
					3-wire (PNP)		F9PWV	F9PW	●	●	○	—		
					2-wire		F9BWW	F9BW	●	●	○	—		
Water resistant (2-color display)	—	—	—	F9BA	—	●	○	—						

*Lead wire length symbols: 20in (0.5 m)Nil (Example) M9N
118in (3 m) L M9NL
197in (5 m)Z M9NZ

*Solid state switches marked with a "○" symbol are produced upon receipt of order.

Compact Cylinder *Series NCQ8*



JIS Symbol

Single acting,
Single return

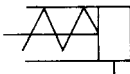

Single acting,
Spring extend

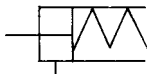

Specifications

Bore size	056 (9/16")	075 (3/4")	106 (1-1/16")	150 (1-1/2")	200 (2")	250 (2-1/2")
Piping size	#10-32UNF	#10-32UNF	NPT1/8	NPT1/8	NPT1/8	NPT1/4
Type	Pneumatic (Non-lube)					
Fluid	Air					
Proof pressure	300PSI (2.1MPa)					
Maximum operating pressure	200PSI (1.4MPa)					
Minimum operating pressure	056	37PSI (0.25MPa)				
	075, 106	26PSI (0.18MPa)				
	150	22PSI (0.15MPa)				
	200, 250	19PSI (0.13MPa)				
Ambient and fluid temperature	Without auto switch	15 to 150°F(-10 to 65°C) (No freezing)				
	With switch	15 to 140°F(-10 to 60°C) (No freezing)				
Cushion	Rubber bumper					
Rod end thread tolerance	Class 2					
Stroke tolerance	0 to +0.04 in (+1.0mm)					
Mounting	Through-hole (B), Both ends tapped (A), Clevis SCH (E, M, N)					
Piston speed	2 to 20in/sec (50 to 500mm/s)					

Applicable Stroke

Unit: inch

Bore size	Standard stroke
056 (9/16")	012 (1/8"), 025 (1/4"), 037 (3/8"), 050 (1/2") 062 (5/8"), 075 (3/4"), 087 (7/8"), 100 (1") 125 (1-1/4"), 150 (1-1/2"), 175 (1-3/4"), 200 (2")
075 (3/4")	
106 (1-1/16")	
150 (1-1/2")	
200 (2")	
250 (2-1/2")	

* With switch is available on strokes 025 (1/4") and greater.

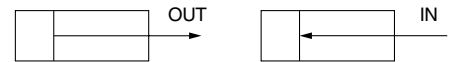

Spring Reaction Force

Single Acting, Spring Return
Single Acting, Spring Extend

Unit: lbs

Bore size (in)	Stroke	Spring reaction force	
		Inlet	Outlet
056 (9/16")	012 (1/8") to 100 (1")	0.76	3.06
	125 (1-1/4") to 200 (2")	0.67	
075 (3/4")	012 (1/8") to 100 (1")	1.42	3.42
	125 (1-1/4") to 200 (2")	1.33	
106 (1-1/16")	012 (1/8") to 100 (1")	2.50	3.73
	125 (1-1/4") to 200 (2")	2.47	
150 (1-1/2")	012 (1/8") to 100 (1")	4.00	6.79
	125 (1-1/4") to 200 (2")	4.09	
200 (2")	012 (1/8") to 100 (1")	4.09	12.1
	125 (1-1/4") to 200 (2")	6.11	
250 (2-1/2")	012 (1/8") to 100 (1")	7.53	14.7
	125 (1-1/4") to 200 (2")	13.9	

Theoretical Output Table

Single Acting, Spring Return

Unit: lbs

Bore size (in)	Pressure (MPa)			
	45 (0.3)	75 (0.5)	145 (1.0)	200 (1.4)
056 (9/16")	8.02	15.2	32.7	45.9
075 (3/4")	16.4	29.3	60.6	84.4
106 (1-1/16")	35.9	61.5	124	171
150 (1-1/2")	72.7	124	249	344
200 (2")	129	220	443	612
250 (2-1/2")	206	348	697	961

Single Acting, Spring Extend

Unit: lbs

Bore size (in)	Pressure (MPa)			
	45 (0.3)	75 (0.5)	145 (1.0)	200 (1.4)
056 (9/16")	5.81	11.5	25.5	36.1
075 (3/4")	13.0	23.6	49.5	69.1
106 (1-1/16")	27.1	47.0	95.8	133
150 (1-1/2")	58.9	101	205	283
200 (2")	109	188	379	524
250 (2-1/2")	186	316	633	873

Option Weights

Unit: OZ

Bore size (in)	Clevis
056 (9/16")	0.71
075 (3/4")	0.93
106 (1-1/16")	1.64
150 (1-1/2")	4.16
200 (2")	6.04
250 (2-1/2")	8.74

Series NCQ8

Weights

Single Acting, Spring Return Without Built-in Magnet

(OZ)

Model \ Stroke	012 (1/8")	025 (1/4")	037 (3/8")	050 (1/2")	062 (5/8")	075 (3/4")	087 (7/8")	100 (1")	125 (1-1/4")	150 (1-1/2")	175 (1-3/4")	200 (2")
NCQ8□056-□S	1.20	1.35	1.49	1.63	1.77	1.91	2.05	2.19	3.25	3.53	3.81	4.10
NCQ8□075-□S	1.87	2.08	2.29	2.50	2.71	2.91	3.12	3.29	4.10	4.52	4.93	4.36
NCQ8□106-□S	3.37	3.74	4.11	4.48	4.85	5.22	5.60	5.97	9.49	10.3	11.0	11.8
NCQ8□150-□S	6.35	6.89	7.43	7.97	8.51	9.05	9.59	10.2	15.5	16.6	17.6	18.7
NCQ8□200-□S	8.98	9.77	10.6	11.4	12.2	13.0	13.8	14.6	16.2	17.8	19.3	20.9
NCQ8□250-□S	14.5	15.3	16.1	16.9	17.7	18.5	19.4	20.2	21.8	23.4	25.0	26.9

Built-in Magnet

(OZ)

Model \ Stroke	012 (1/8")	025 (1/4")	037 (3/8")	050 (1/2")	062 (5/8")	075 (3/4")	087 (7/8")	100 (1")	125 (1-1/4")	150 (1-1/2")	175 (1-3/4")	200 (2")
NCDQ8□056-□S	—	2.53	2.67	2.81	2.95	3.09	3.23	3.37	4.43	4.71	5.00	5.28
NCDQ8□075-□S	—	3.99	4.20	4.40	4.61	4.82	5.03	5.22	6.00	6.42	6.84	6.27
NCDQ8□106-□S	—	7.09	7.46	7.83	8.21	8.58	8.95	9.32	12.9	13.6	14.4	15.1
NCDQ8□150-□S	—	12.6	13.1	13.6	14.2	14.7	15.3	15.8	21.1	22.2	23.3	24.3
NCDQ8□200-□S	—	18.0	18.8	19.6	20.4	21.2	22.0	22.7	24.3	25.9	27.5	29.1
NCDQ8□250-□S	—	25.5	26.3	27.1	27.9	28.7	29.5	30.3	32.0	33.6	35.2	36.8

Super Compact with Built-in Magnet

(OZ)

Model \ Stroke	012 (1/8")	025 (1/4")	037 (3/8")	050 (1/2")	062 (5/8")	075 (3/4")	087 (7/8")	100 (1")	125 (1-1/4")	150 (1-1/2")	175 (1-3/4")	200 (2")
NCDQ8□Z056-□S	—	2.00	2.14	2.28	2.42	2.56	2.70	2.84	3.90	4.18	4.47	4.75
NCDQ8□Z075-□S	—	3.16	3.37	3.57	3.78	3.99	4.20	4.41	5.18	5.59	6.01	5.44
NCDQ8□Z106-□S	—	5.15	5.52	5.90	6.27	6.64	7.01	7.38	10.9	11.7	12.4	13.2
NCDQ8□Z150-□S	—	9.19	9.73	10.3	10.9	11.4	11.9	12.5	17.8	18.9	19.9	21.0
NCDQ8□Z200-□S	—	12.6	13.4	14.2	15.0	15.8	16.6	17.4	19.0	20.5	22.1	23.7
NCDQ8□Z250-□S	—	18.8	19.6	20.4	21.2	22.1	22.9	23.7	25.3	26.9	28.5	30.2

Single Acting, Spring Extend Without Built-in Magnet

(OZ)

Model \ Stroke	012 (1/8")	025 (1/4")	037 (3/8")	050 (1/2")	062 (5/8")	075 (3/4")	087 (7/8")	100 (1")	125 (1-1/4")	150 (1-1/2")	175 (1-3/4")	200 (2")
NCQ8□056-□T	1.42	1.56	1.70	1.84	1.98	2.12	2.26	2.40	3.34	3.62	3.90	4.18
NCQ8□075-□T	2.19	2.40	2.61	2.82	3.02	3.23	3.44	3.65	5.02	5.43	5.85	4.36
NCQ8□106-□T	4.96	5.33	5.70	6.07	6.44	6.81	7.18	7.55	10.3	11.0	11.8	12.5
NCQ8□150-□T	8.12	8.66	9.20	9.74	10.3	10.9	11.4	11.9	16.3	17.4	18.5	19.5
NCQ8□200-□T	12.2	13.0	13.8	14.6	15.4	16.2	17.0	17.8	19.4	20.9	22.5	24.1
NCQ8□250-□T	20.6	21.4	22.2	23.0	23.8	24.6	25.5	26.3	27.9	29.5	31.1	33.0

Built-in Magnet

(OZ)

Model \ Stroke	012 (1/8")	025 (1/4")	037 (3/8")	050 (1/2")	062 (5/8")	075 (3/4")	087 (7/8")	100 (1")	125 (1-1/4")	150 (1-1/2")	175 (1-3/4")	200 (2")
NCDQ8□056-□T	—	2.74	2.88	3.02	3.16	3.30	3.44	3.58	4.52	4.80	5.08	5.37
NCDQ8□075-□T	—	4.37	4.58	4.73	5.00	5.21	5.42	5.58	6.39	6.81	7.22	6.27
NCDQ8□106-□T	—	8.68	9.05	9.42	9.79	10.2	10.6	10.9	13.6	14.4	15.1	15.9
NCDQ8□150-□T	—	13.2	13.7	14.2	14.8	15.3	15.9	16.4	20.7	21.8	22.9	24.0
NCDQ8□200-□T	—	21.1	21.9	22.7	23.5	24.2	25.0	25.8	27.4	29.0	30.6	32.2
NCDQ8□250-□T	—	31.6	32.4	33.2	34.0	34.8	35.6	36.4	38.1	39.7	41.3	42.9

Super Compact with Built-in Magnet

(OZ)

Model \ Stroke	012 (1/8")	025 (1/4")	037 (3/8")	050 (1/2")	062 (5/8")	075 (3/4")	087 (7/8")	100 (1")	125 (1-1/4")	150 (1-1/2")	175 (1-3/4")	200 (2")
NCDQ8□Z056-□T	—	2.21	2.35	2.49	2.63	2.77	2.91	3.06	3.99	4.27	4.55	4.84
NCDQ8□Z075-□T	—	3.55	3.75	3.96	4.17	4.38	4.59	4.79	5.56	5.98	6.40	5.44
NCDQ8□Z106-□T	—	6.74	7.11	7.48	7.85	8.22	8.59	8.96	11.7	12.4	13.2	13.9
NCDQ8□Z150-□T	—	10.9	11.5	12.0	12.5	13.1	13.6	14.2	18.5	19.6	20.7	21.8
NCDQ8□Z200-□T	—	15.7	16.5	17.3	18.1	18.9	19.7	20.5	22.1	23.7	25.3	26.9
NCDQ8□Z250-□T	—	24.9	25.7	26.5	27.3	28.2	29.0	29.8	31.4	33.0	34.6	36.3

Mounting Bolt

Mounting method: Mounting bolt for through-hole style of NCQ8B is available as an option.

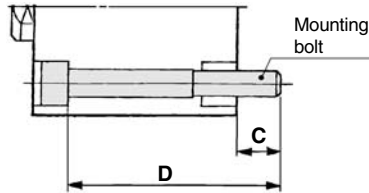

Mounting Bolt Size for NCQ8B056 to 250-□S (Without Auto Switch)

(Inch)

Model	C	D	Bolt size	
NCQ8B056-012S	0.18	1	#4-40UNC-1	
025S		1-1/8	1-1/8	
037S		1-1/4	1-1/4	
050S		1-3/8	1-3/8	
062S		1-1/2	1-1/2	
075S		1-5/8	1-5/8	
087S		1-3/4	1-3/4	
100S		1-7/8	1-7/8	
125S		2-3/4	2-3/4	
150S		3	3	
175S	0.25	3-1/4	3-1/4	
200S		3-1/2	3-1/2	
NCQ8B075-012S		0.21	1	#6-32UNC-1
025S			1-1/8	1-1/8
037S	1-1/4		1-1/4	
050S	1-3/8		1-3/8	
062S	1-1/2		1-1/2	
075S	1-5/8		1-5/8	
087S	1-3/4		1-3/4	
100S	1-7/8		1-7/8	
125S	2-3/4		2-3/4	
150S	3		3	
175S	0.27	3-1/4	3-1/4	
200S		3-1/2	3-1/2	
NCQ8B106-012S		0.27	1-1/8	#6-32UNC- 1-1/8
025S			1-1/4	1-1/4
037S	1-3/8		1-3/8	
050S	1-1/2		1-1/2	
062S	1-5/8		1-5/8	
075S	1-3/4		1-3/4	
087S	1-7/8		1-7/8	
100S	2		2	
125S	2-7/8		2-7/8	
150S	3-1/8		3-1/8	
175S	3-3/8		3-3/8	
200S	3-5/8		3-5/8	

Model	C	D	Bolt size	
NCQ8B150-012S	0.33	1-1/8	#10-24UNC- 1-1/8	
025S		1-1/4	1-1/4	
037S		1-3/8	1-3/8	
050S		1-1/2	1-1/2	
062S		1-5/8	1-5/8	
075S		1-3/4	1-3/4	
087S		1-7/8	1-7/8	
100S		2	2	
125S		3	3	
150S		3-1/4	3-1/4	
175S	0.45	3-1/2	3-1/2	
200S		3-3/4	3-3/4	
NCQ8B200-012S		0.39	1-1/4	#10-24UNC- 1-1/4
025S			1-3/8	1-3/8
037S	1-1/2		1-1/2	
050S	1-5/8		1-5/8	
062S	1-3/4		1-3/4	
075S	1-7/8		1-7/8	
087S	2		2	
100S	2-1/8		2-1/8	
125S	3		3	
150S	3-1/4		3-1/4	
175S	0.45	3-1/2	3-1/2	
200S		3-3/4	3-3/4	
NCQ8B250-012S		0.45	1-1/2	1/4-20UNC- 1-1/2
025S			1-5/8	1-5/8
037S	1-3/4		1-3/4	
050S	1-7/8		1-7/8	
062S	2		2	
075S	2-1/8		2-1/8	
087S	2-1/4		2-1/4	
100S	2-3/8		2-3/8	
125S	3-1/2		3-1/2	
150S	3-3/4		3-3/4	
175S	4		4	
200S	4-1/4		4-1/4	

Series NCDQ8

Mounting Bolt Size for NCDQ8B056 to 250-□S (With Auto Switch)

(Inch)

Model	C	D	Bolt size	
NCDQ8B056-025S	0.18	1-3/4	#4-40UNC- 1-3/4	
037S		1-7/8	1-7/8	
050S		2	2	
062S		2-1/8	2-1/8	
075S		2-1/4	2-1/4	
087S		2-3/8	2-3/8	
100S		2-1/2	2-1/2	
125S		0.25	3-3/8	3-3/8
150S			3-5/8	3-5/8
175S			3-7/8	3-7/8
200S	4-1/8		4-1/8	
NCDQ8B075-025S	0.21	2	#6-32UNC- 2	
037S		2-1/8	2-1/8	
050S		2-1/4	2-1/4	
062S		2-3/8	2-3/8	
075S		2-1/2	2-1/2	
087S		2-5/8	2-5/8	
100S		2-3/4	2-3/4	
125S		0.27	3-5/8	3-5/8
150S			3-7/8	3-7/8
175S			4-1/8	4-1/8
200S	4-3/8		4-3/8	
NCDQ8B106-025S	0.27	2-1/8	#6-32UNC- 2-1/8	
037S		2-1/4	2-1/4	
050S		2-3/8	2-3/8	
062S		2-1/2	2-1/2	
075S		2-5/8	2-5/8	
087S		2-3/4	2-3/4	
100S		2-7/8	2-7/8	
125S		3-3/4	3-3/4	
150S		4	4	
175S		4-1/4	4-1/4	
200S	4-1/2	4-1/2		

Model	C	D	Bolt size
NCDQ8B150-025S	0.33	2-1/8	#10-24UNC- 2-1/8
037S		2-1/4	2-1/4
050S		2-3/8	2-3/8
062S		2-1/2	2-1/2
075S		2-5/8	2-5/8
087S		2-3/4	2-3/4
100S		2-7/8	2-7/8
125S		3-3/4	3-3/4
150S		4	4
175S		4-1/4	4-1/4
200S	4-1/2	4-1/2	
NCDQ8B200-025S	0.39	2-1/4	#10-24UNC- 2-1/4
037S		2-3/8	2-3/8
050S		2-1/2	2-1/2
062S		2-5/8	2-5/8
075S		2-3/4	2-3/4
087S		2-7/8	2-7/8
100S		3	3
125S		3-7/8	3-7/8
150S		4-1/8	4-1/8
175S		4-3/8	4-3/8
200S	4-5/8	4-5/8	
NCDQ8B250-025S	0.45	2-1/2	1/4-20UNC- 2-1/2
037S		2-5/8	2-5/8
050S		2-3/4	2-3/4
062S		2-7/8	2-7/8
075S		3	3
087S		3-1/8	3-1/8
100S		3-1/4	3-1/4
125S		4-3/8	4-3/8
150S		4-5/8	4-5/8
175S		4-7/8	4-7/8
200S	5-1/8	5-1/8	

Mounting Bolt Size for NCDQ8BZ056 to 250-□S (With Auto Switch)

(Inch)

Model	C	D	Bolt size	
NCDQ8BZ056-025S	0.19	1-1/2	#4-40UNC-1-1/2	
037S		1-5/8	1-5/8	
050S		1-3/4	1-3/4	
062S		1-7/8	1-7/8	
075S		2	2	
087S		2-1/8	2-1/8	
100S		2-1/4	2-1/4	
125S		0.25	3-1/8	3-1/8
150S			3-3/8	3-3/8
175S			3-5/8	3-5/8
200S	3-7/8		3-7/8	
NCDQ8BZ075-025S	0.21	1-1/2	#6-32UNC- 1-1/2	
037S		1-5/8	1-5/8	
050S		1-3/4	1-3/4	
062S		1-7/8	1-7/8	
075S		2	2	
087S		2-1/8	2-1/8	
100S		2-1/4	2-1/4	
125S		0.27	3-1/8	3-1/8
150S			3-3/8	3-3/8
175S			3-5/8	3-5/8
200S	3-7/8		3-7/8	
NCDQ8BZ106-025S	0.27	1-5/8	#6-32UNC- 1-5/8	
037S		1-3/4	1-3/4	
050S		1-7/8	1-7/8	
062S		2	2	
075S		2-1/8	2-1/8	
087S		2-1/4	2-1/4	
100S		2-3/8	2-3/8	
125S		3-1/4	3-1/4	
150S		3-1/2	3-1/2	
175S		3-3/4	3-3/4	
200S	4	4		

Model	C	D	Bolt size
NCDQ8BZ150-025S	0.33	1-5/8	#10-24UNC- 1-5/8
037S		1-3/4	1-3/4
050S		1-7/8	1-7/8
062S		2	2
075S		2-1/8	2-1/8
087S		2-1/4	2-1/4
100S		2-3/8	2-3/8
125S		3-1/4	3-1/4
150S		3-1/2	3-1/2
175S		3-3/4	3-3/4
200S	4	4	
NCDQ8BZ200-025S	0.39	1-5/8	#10-24UNC- 1-5/8
037S		1-3/4	1-3/4
050S		1-7/8	1-7/8
062S		2	2
075S		2-1/8	2-1/8
087S		2-1/4	2-1/4
100S		2-3/8	2-3/8
125S		2-5/8	3-1/4
150S		2-7/8	3-1/2
175S		3-1/8	3-3/4
200S	3-3/8	4	
NCDQ8BZ250-025S	0.45	1-7/8	1/4-20UNC- 1-7/8
037S		2	2
050S		2-1/8	2-1/8
062S		2-1/4	2-1/4
075S		2-3/8	2-3/8
087S		2-1/2	2-1/2
100S		2-5/8	2-5/8
125S		3-3/4	3-3/4
150S		4	4
175S		4-1/4	4-1/4
200S	4-1/2	4-1/2	

Mounting Bolt

Mounting method: Mounting bolt for through-hole style of NCQ8B is available as an option.

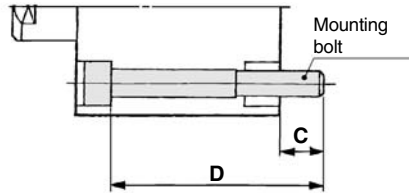

Mounting Bolt Size for NCQ8B056 to 250-□T (Without Auto Switch)

(Inch)

Model	C	D	Bolt size	
NCQ8B056-012T	0.19	1-1/4	#4-40UNC- 1-1/4	
025T		1-3/8	1-3/8	
037T		1-1/2	1-1/2	
050T		1-5/8	1-5/8	
062T		1-3/4	1-3/4	
075T		1-7/8	1-7/8	
087T		2	2	
100T		2-1/8	2-1/8	
125T		0.25	3	3
150T			3-1/4	3-1/4
175T	3-1/2		3-1/2	
200T	3-3/4		3-3/4	
NCQ8B075-012T	0.21	1-1/4	#6-32UNC- 1-1/4	
025T		1-3/8	1-3/8	
037T		1-1/2	1-1/2	
050T		1-5/8	1-5/8	
062T		1-3/4	1-3/4	
075T		1-7/8	1-7/8	
087T		2	2	
100T		2-1/8	2-1/8	
125T		0.27	3	3
150T			3-1/4	3-1/4
175T	3-1/2		3-1/2	
200T	3-3/4		3-3/4	
NCQ8B106-012T	0.27	1-5/8	#6-32UNC- 1-5/8	
025T		1-3/4	1-3/4	
037T		1-7/8	1-7/8	
050T		2	2	
062T		2-1/8	2-1/8	
075T		2-1/4	2-1/4	
087T		2-3/8	2-3/8	
100T		2-1/2	2-1/2	
125T		3-3/8	3-3/8	
150T		3-5/8	3-5/8	
175T		3-7/8	3-7/8	
200T		4-1/8	4-1/8	

Model	C	D	Bolt size
NCQ8B150-012T	0.33	1-5/8	#10-24UNC- 1-5/8
025T		1-3/4	1-3/4
037T		1-7/8	1-7/8
050T		2	2
062T		2-1/8	2-1/8
075T		2-1/4	2-1/4
087T		2-3/8	2-3/8
100T		2-1/2	2-1/2
125T		3-3/8	3-3/8
150T		3-5/8	3-5/8
175T	3-7/8	3-7/8	
200T	4-1/8	4-1/8	
NCQ8B200-012T	0.39	1-3/4	#10-24UNC- 1-3/4
025T		1-7/8	1-7/8
037T		2	2
050T		2-1/8	2-1/8
062T		2-1/4	2-1/4
075T		2-3/8	2-3/8
087T		2-1/2	2-1/2
100T		2-5/8	2-5/8
125T		3-1/2	3-1/2
150T		3-3/4	3-3/4
175T	4	4	
200T	4-1/4	4-1/4	
NCQ8B250-012T	0.45	2-1/4	1/4-20UNC- 2-1/4
025T		2-3/8	2-3/8
037T		2-1/2	2-1/2
050T		2-5/8	2-5/8
062T		2-3/4	2-3/4
075T		2-7/8	2-7/8
087T		3	3
100T		3-1/8	3-1/8
125T		4-1/4	4-1/4
150T		4-1/2	4-1/2
175T	4-3/4	4-3/4	
200T	5	5	

Series NQ8

Mounting Bolt Size for NCDQ8B056 to 250-□T (With Auto Switch)

(Inch)

Model	C	D	Bolt size
NCDQ8B056-025T	0.18	1-3/4	#4-40UNC- 1-3/4
037T		1-7/8	1-7/8
050T		2	2
062T		2-1/8	2-1/8
075T		2-1/4	2-1/4
087T		2-3/8	2-3/8
100T		2-1/2	2-1/2
125T		0.25	3-3/8
150T	3-5/8		3-5/8
175T	3-7/8		3-7/8
200T	4-1/8		4-1/8
NCDQ8B075-025T	0.21	2-1/4	#6-32UNC- 2-1/4
037T		2-3/8	2-3/8
050T		2-1/2	2-1/2
062T		2-5/8	2-5/8
075T		2-3/4	2-3/4
087T		2-7/8	2-7/8
100T		3	3
125T		0.27	3-7/8
150T	4-1/8		4-1/8
175T	4-3/8		4-3/8
200T	4-5/8		4-5/8
NCDQ8B106-025T	0.27	2-5/8	#6-32UNC- 2-5/8
037T		2-3/4	2-3/4
050T		2-7/8	2-7/8
062T		3	3
075T		3-1/8	3-1/8
087T		3-1/4	3-1/4
100T		3-3/8	3-3/8
125T		4-1/4	4-1/4
150T		4-1/2	4-1/2
175T		4-3/4	4-3/4
200T		5	5

Model	C	D	Bolt size
NCDQ8B150-025T	0.33	2-5/8	#10-24UNC- 2-5/8
037T		2-3/4	2-3/4
050T		2-7/8	2-7/8
062T		3	3
075T		3-1/8	3-1/8
087T		3-1/4	3-1/4
100T		3-3/8	3-3/8
125T		0.39	4-1/4
150T	4-1/2		4-1/2
175T	4-3/4		4-3/4
200T	5		5
NCDQ8B200-025T	0.39	2-3/4	#10-24UNC- 2-3/4
037T		2-7/8	2-7/8
050T		3	3
062T		3-1/8	3-1/8
075T		3-1/4	3-1/4
087T		3-3/8	3-3/8
100T		3-1/2	3-1/2
125T		0.45	4-3/8
150T	4-5/8		4-5/8
175T	4-7/8		4-7/8
200T	5-1/8		5-1/8
NCDQ8B250-025T	0.45	3-1/4	1/4-20UNC- 3-1/4
037T		3-3/8	3-3/8
050T		3-1/2	3-1/2
062T		3-5/8	3-5/8
075T		3-3/4	3-3/4
087T		3-7/8	3-7/8
100T		4	4
125T		5-1/8	5-1/8
150T		5-3/8	5-3/8
175T		5-5/8	5-5/8
200T		5-7/8	5-7/8

Mounting Bolt Size for NCDQ8BZ056 to 250-□T (With Auto Switch)

(Inch)

Model	C	D	Bolt size
NCDQ8BZ056-025T	0.19	1-5/8	#4-40UNC- 1-5/8
037T		1-3/4	1-3/4
050T		1-7/8	1-7/8
062T		2	2
075T		2-1/8	2-1/8
087T		2-1/4	2-1/4
100T		2-3/8	2-3/8
125T		0.25	3-1/4
150T	3-1/2		3-1/2
175T	3-3/4		3-3/4
200T	4		4
NCDQ8BZ075-025T	0.21	1-7/8	#6-32UNC- 1-7/8
037T		2	2
050T		2-1/8	2-1/8
062T		2-1/4	2-1/4
075T		2-3/8	2-3/8
087T		2-1/2	2-1/2
100T		2-5/8	2-5/8
125T		0.27	3-1/2
150T	3-3/4		3-3/4
175T	4		4
200T	4-1/2		4-1/2
NCDQ8BZ106-025T	0.27	2-1/8	#6-32UNC- 2-1/8
037T		2-1/4	2-1/4
050T		2-3/8	2-3/8
062T		2-1/2	2-1/2
075T		2-5/8	2-5/8
087T		2-3/4	2-3/4
100T		2-7/8	2-7/8
125T		3-3/4	3-3/4
150T		4	4
175T		4-1/4	4-1/4
200T		4-1/2	4-1/2

Model	C	D	Bolt size
NCDQ8BZ150-025T	0.33	2-1/8	#10-24UNC- 2-1/8
037T		2-1/4	2-1/4
050T		2-3/8	2-3/8
062T		2-1/2	2-1/2
075T		2-5/8	2-5/8
087T		2-3/4	2-3/4
100T		2-7/8	2-7/8
125T		0.39	3-3/4
150T	4		4
175T	4-1/4		4-1/4
200T	4-1/2		4-1/2
NCDQ8BZ200-025T	0.39	2-1/8	#10-24UNC- 2-1/8
037T		2-1/4	2-1/4
050T		2-3/8	2-3/8
062T		2-1/2	2-1/2
075T		2-5/8	2-5/8
087T		2-3/4	2-3/4
100T		2-7/8	2-7/8
125T		0.45	3-3/4
150T	4		4
175T	4-1/4		4-1/4
200T	4-1/2		4-1/2
NCDQ8BZ250-025T	0.45	2-5/8	1/4-20UNC- 2-5/8
037T		2-3/4	2-3/4
050T		2-7/8	2-7/8
062T		3	3
075T		3-1/8	3-1/8
087T		3-1/4	3-1/4
100T		3-3/8	3-3/8
125T		4-1/2	4-1/2
150T		4-3/4	4-3/4
175T		5	5
200T		5-1/4	5-1/4

Construction/Single Acting Spring Return

Without auto switch

Here is the typical, cross-sectional construction. For details for each model, refer to the instruction manual.

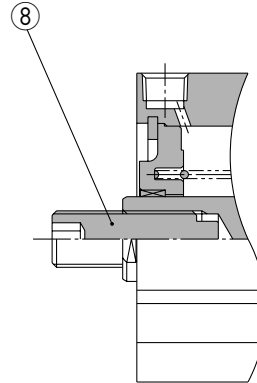
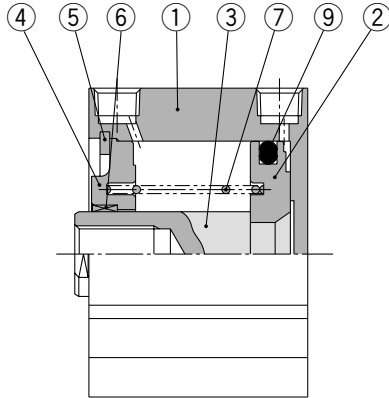

Parts List

No.	Description	Material	Remarks
1	Cylinder tube	Aluminum alloy	Hard anodized
2	Piston	Aluminum alloy	Chromated
3	Piston rod	Stainless steel	056 to 106
		Carbon steel	150 to 250 Hard chrome plated
4	Collar	Aluminum alloy	056, 075, 106, 200, 250 Anodized
		Stainless steel	150
5	Snap ring	Carbon tool steel	Phosphate coated

Male thread

No.	Description	Material	Remarks
6	Bushing	Oil-impregnated sintered alloy	106 only
		Phosphor bronze alloy	150, 200, 250 only
7	Return spring	Piano wire	Zinc chromated
8	Stud	Steel alloy	Electroless nickel plated
9	Piston seal	NBR	

Repair Parts: Seal Kit for Single Acting Spring Return, Single Rod

Bore size	Kit no.	Remarks
056 (9/16")	NCQ8B056-S-PS	Piston seal is included.
075 (3/4")	NCQ8B075-S-PS	
106 (1-1/16")	NCQ8B106-S-PS	
150 (1-1/2")	NCQ8B150-S-PS	
200 (2")	NCQ8B200-S-PS	
250 (2-1/2")	NCQ8B250-S-PS	

With auto switch

Here is the typical, cross-sectional construction. For details for each model, refer to the instruction manual.

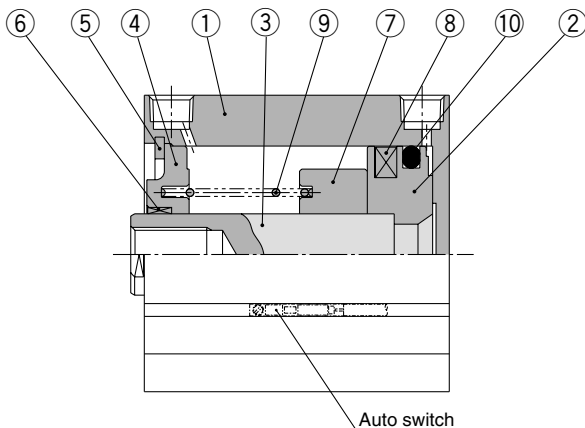

Parts List

No.	Description	Material	Remarks
1	Cylinder tube	Aluminum alloy	Hard anodized
2	Piston	Aluminum alloy	Chromated
3	Piston rod	Stainless steel	056 to 106
		Carbon steel	150 to 250 Hard chrome plated
4	Collar	Aluminum alloy	056, 075, 106, 200, 250 Anodized
		Stainless steel	150
5	Snap ring	Carbon tool steel	Phosphate coated
6	Bushing	Oil-impregnated sintered alloy	106 only
		Phosphor bronze alloy	150, 200, 250 only
7	Spacer	Aluminum alloy	Chromated, Use for standard type only.
8	Magnet	—	
9	Return spring	Piano wire	Zinc chromated
10	Piston seal	NBR	

Repair Parts: Seal Kit for Single Acting Spring Return, Single Rod

The part number will be the same as the one without auto switches.

Series NCQ8

Construction/Single Acting Spring Extend

Without auto switch

Here is the typical, cross-sectional construction. For details for each model, refer to the instruction manual.

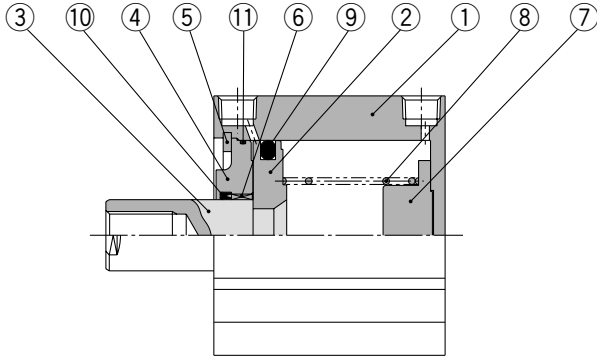

Parts List

No.	Description	Material	Remarks
1	Cylinder tube	Aluminum alloy	Hard anodized
2	Piston	Aluminum alloy	Chromated
3	Piston rod	Stainless steel	056 to 106
		Carbon steel	150 to 250 Hard chrome plated
4	Collar	Aluminum alloy	Anodized
5	Snap ring	Carbon tool steel	Phosphate coated
6	Bushing	Phosphor bronze alloy	200, 250 only
7	Spacer	Aluminum alloy	Chromated
8	Return spring	Piano wire	Zinc chromated
9	Piston seal	NBR	
10	Rod seal	NBR	
11	Tube gasket	NBR	

Repair Parts: Seal Kit for Single Acting Spring Extend, Single Rod

Bore size	Kit no.	Remarks
056 (9/16")	NCQ8B056-T-PS	Piston seal, rod seal and, tube gasket are included.
075 (3/4")	NCQ8B075-T-PS	
106 (1-1/16")	NCQ8B106-T-PS	
150 (1-1/2")	NCQ8B150-T-PS	
200 (2")	NCQ8B200-T-PS	
250 (2-1/2")	NCQ8B250-T-PS	

With auto switch

Here is the typical, cross-sectional construction. For details for each model, refer to the instruction manual.

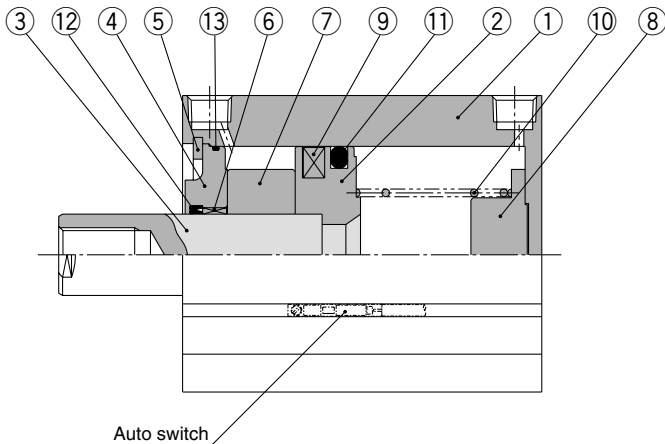

Parts List

No.	Description	Material	Remarks
1	Cylinder tube	Aluminum alloy	Hard anodized
2	Piston	Aluminum alloy	Chromated
3	Piston rod	Stainless steel	056 to 106
		Carbon steel	150 to 250 Hard chrome plated
4	Collar	Aluminum alloy	Anodized
5	Snap ring	Carbon tool steel	Phosphate coated
6	Bushing	Phosphor bronze alloy	200, 250 only
7	Spacer	Aluminum alloy	Chromated, Use for standard type only
8	Spacer A	Aluminum alloy	Chromated
9	Magnet	—	
10	Return spring	Piano wire	Zinc chromated
11	Piston seal	NBR	
12	Rod seal	NBR	
13	Tube gasket	NBR	

Repair Parts: Seal Kit for Single Acting Spring Extend, Single Rod

The part number will be the same as the one without auto switches.

Compact Cylinder Single Acting, Single Rod **Series NCQ8**

Dimensions/NCQ8B056 to 106-□S (Refer to page 44 for both ends tapped and male thread dimensions.)

056 (9/16")

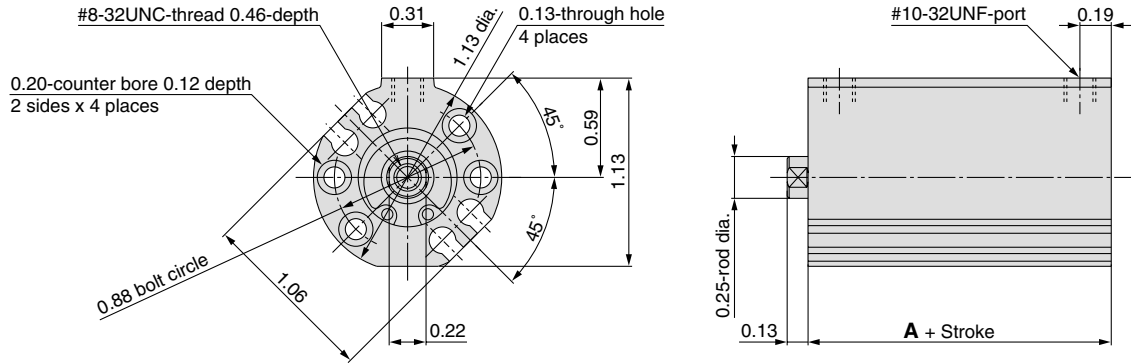

(Inch)

Stroke	Symbol A
1/8" to 1"	0.81
1 1/4" to 2"	1.38

075 (3/4"), 106 (1-1/16")

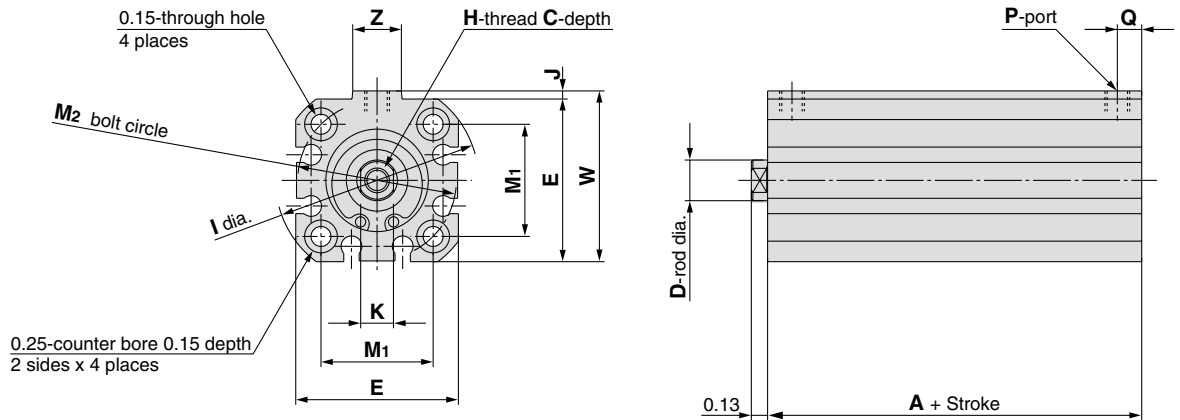

(Inch)

Symbol Bore	A		C		D	E	H	I	J	K	M ₁	M ₂	P	Q	W	Z
	1/8" to 1"st	1 1/4" to 2"st	1/8" to 1/4"st	3/8" to 2"st												
075 (3/4")	0.81	1.38	0.46		0.31	1.25	#10-32UNF	1.56	0.06	0.25	0.86	1.22	#10-32UNF	0.19	1.31	0.38
106 (1-1/16")	0.88	1.50	0.52	0.70	0.50	1.56	5/16-24UNF	2.03	0.16	0.44	1.19	1.69	NPT1/8	0.25	1.72	0.56

Series NCQ8

Dimensions/NCQ8B150 to 250-□S (Refer to page 44 for both ends tapped and male thread dimensions.)

150 (1-1/2"), 200 (2"), 250 (2-1/2")

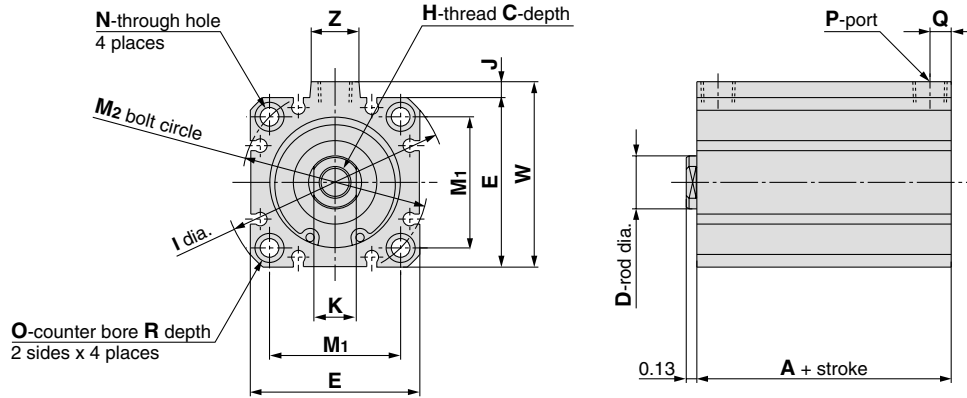

Symbol	A		C			D	E	H	I	J	K	M ₁	M ₂	N	O	P	Q	R	W	Z
	1/8" to 1"st	1 1/4" to 2"st	1/8"st	1/4"st	3/8" to 2"st															
150 (1-1/2")	0.88	1.50	0.50	0.70	0.63	2.00	3/8-24UNF	2.63	0.19	0.50	1.55	2.19	0.22	0.34	NPT1/8	0.25	0.20	2.19	0.56	
200 (2")	0.94	1.56	0.44	0.70	0.75	2.53	1/2-20UNF	3.13	0.20	0.63	1.90	2.69	0.22	0.34	NPT1/8	0.25	0.20	2.73	0.56	
250 (2-1/2")	1.19	2.06	0.44	0.70	0.75	2.84	1/2-20UNF	3.75	0.39	0.63	2.30	3.25	0.28	0.41	NPT1/4	0.33	0.26	3.23	0.69	

Compact Cylinder Single Acting, Single Rod **Series NCQ8**

Dimensions/NCQ8B056 to 106-□S (Refer to page 44 for both ends tapped and male thread dimensions.)

056 (9/16")

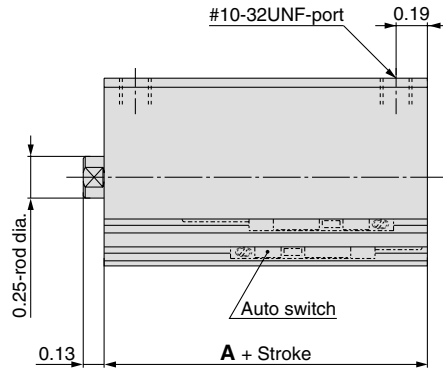
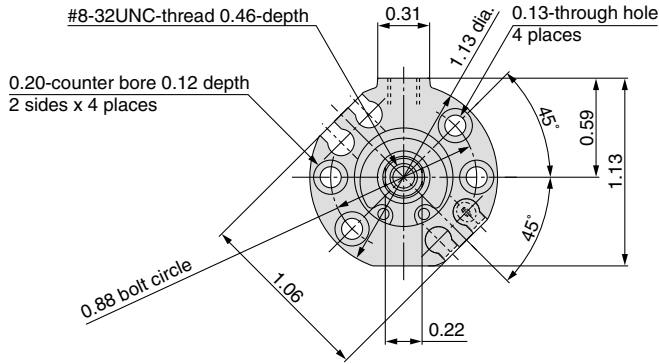

(Inch)

Symbol	A
Stroke	
1/4" to 1"	1.44
1-1/4" to 2"	2.00

075 (3/4"), 106 (1-1/16")

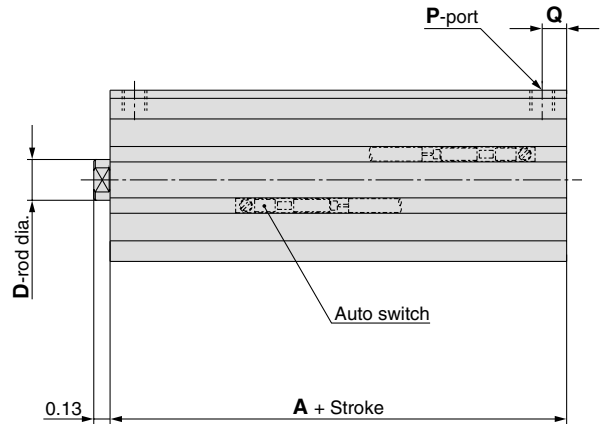
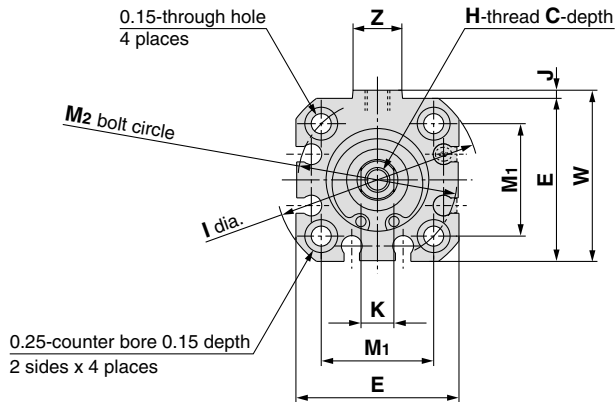

(Inch)

Symbol	A		C	D	E	H	I	J	K	M ₁	M ₂	P	Q	W	Z
	1/8" to 1"st	1-1/4" to 2"st													
075 (3/4")	1.69	2.25	0.46	0.31	1.25	#10-32UNF	1.56	0.06	0.25	0.86	1.22	#10-32UNF	0.19	1.31	0.38
106 (1-1/16")	1.75	2.38	0.70	0.50	1.56	5/16-24UNF	2.03	0.16	0.44	1.19	1.69	NPT1/8	0.25	1.72	0.56

Series NCQ8

Dimensions/NCDQ8B150 to 250-S (Refer to page 44 for both ends tapped and male thread dimensions.)

150 (1-1/2"), 200 (2"), 250 (2-1/2")

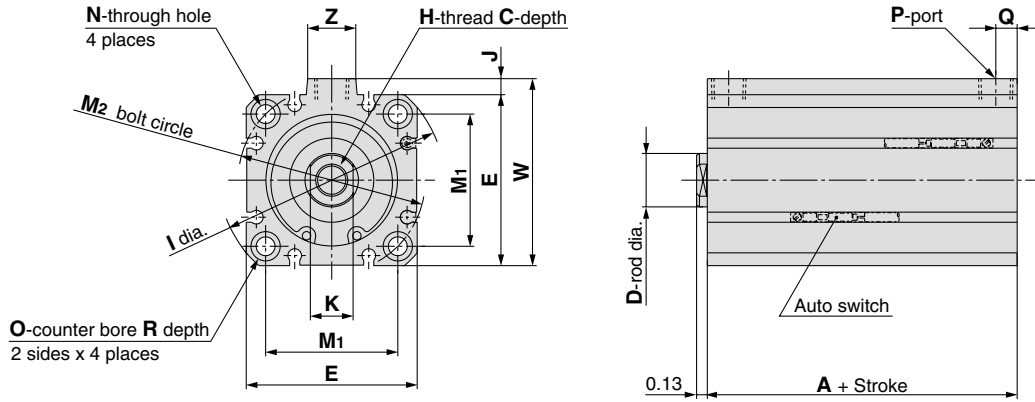

Symbol Bore	A		C	D	E	H	I	J	K	M ₁	M ₂	N	O	P	Q	R	W	Z
	1/4" to 1"st	1-1/4" to 2"st																
150 (1-1/2")	1.75	2.38	0.70	0.63	2.00	3/8-24UNF	2.63	0.19	0.50	1.55	2.19	0.22	0.34	NPT1/8	0.25	0.20	2.19	0.56
200 (2")	1.81	2.44	0.70	0.75	2.53	1/2-20UNF	3.13	0.20	0.63	1.90	2.69	0.22	0.34	NPT1/8	0.25	0.20	2.73	0.56
250 (2-1/2")	2.06	2.94	0.70	0.75	2.84	1/2-20UNF	3.75	0.39	0.63	2.30	3.25	0.28	0.41	NPT1/4	0.33	0.26	3.23	0.69

(Inch)

Compact Cylinder Single Acting, Single Rod **Series NCQ8**

Dimensions/NCQ8BZ056 to 106-□S (Refer to page 44 for both ends tapped and male thread dimensions.)

056 (9/16")

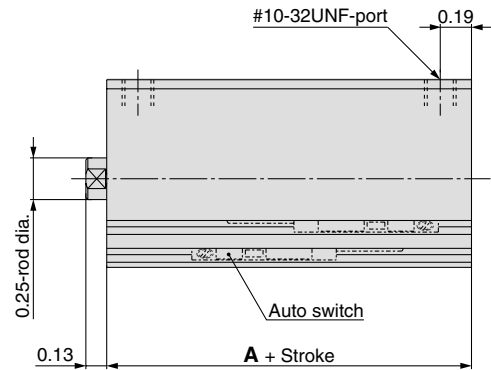
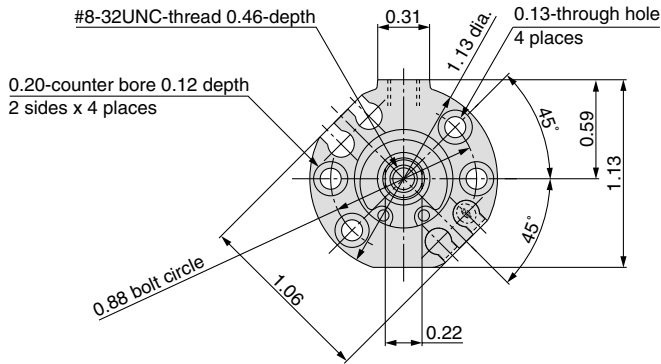

(Inch)

Stroke	Symbol	A
1/4" to 1"		1.19
1 1/4" to 2"		1.75

075 (3/4"), 106 (1-1/16")

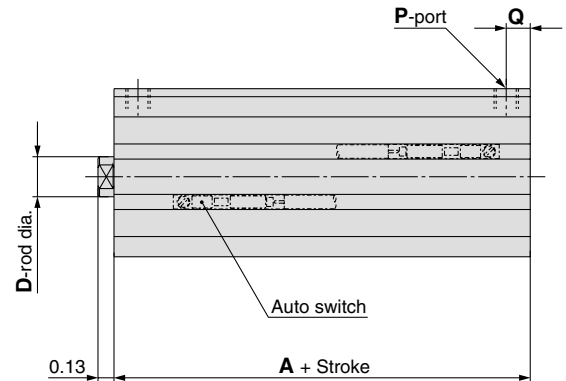
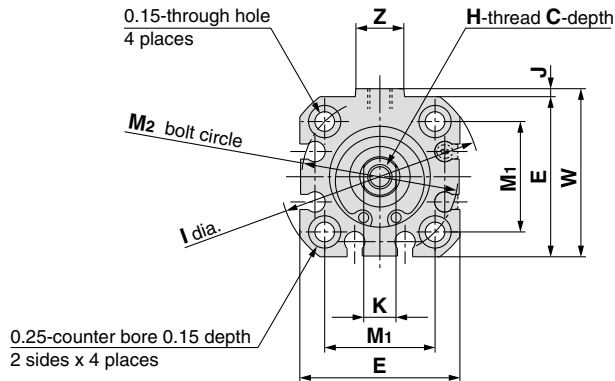

(Inch)

Symbol	A		C		D	E	H	I	J	K	M1	M2	P	Q	W	Z
	1/4" to 1"st	1-1/4" to 2"st	1/4"st	3/8" to 2"st												
075 (3/4")	1.19	1.75	0.46		0.31	1.25	#10-32UNF	1.56	0.06	0.25	0.86	1.22	#10-32UNF	0.19	1.31	0.38
106 (1-1/16")	1.25	1.88	0.52	0.70	0.50	1.56	5/16-24UNF	2.03	0.16	0.44	1.19	1.69	NPT1/8	0.25	1.72	0.56

Series NCDQ8

Dimensions/NCDQ8BZ150 to 250-S (Refer to page 44 for both ends tapped and male thread dimensions.)

150 (1-1/2"), 200 (2"), 250 (2-1/2")

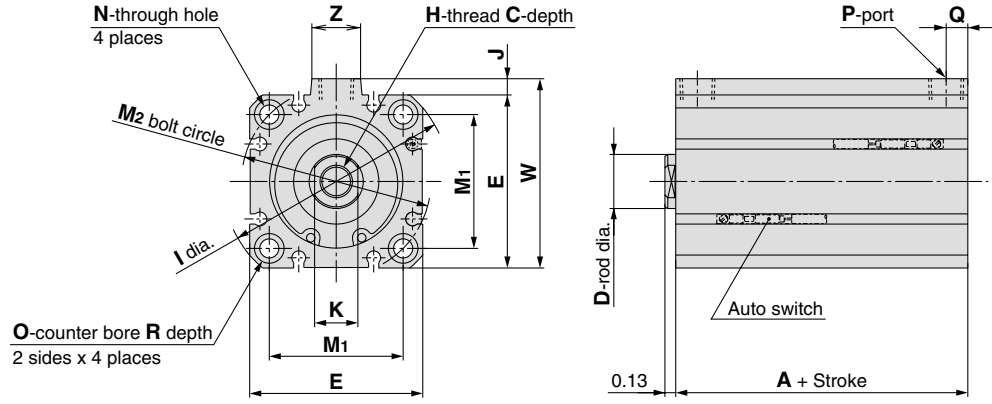

(Inch)

Symbol	A		C		D	E	H	I	J	K	M ₁	M ₂	N	O	P	Q	R	W	Z
	1/4" to 1"st	1-1/4 to 2"st	1/4"st	3/8" to 2"st															
150 (1-1/2")	1.25	1.88	0.50	0.70	0.63	2.00	3/8-24UNF	2.63	0.19	0.50	1.55	2.19	0.22	0.34	NPT1/8	0.25	0.20	2.19	0.56
200 (2")	1.19	1.81	0.70		0.75	2.53	1/2-20UNF	3.13	0.20	0.63	1.90	2.69	0.22	0.34	NPT1/8	0.25	0.20	2.73	0.56
250 (2-1/2")	1.44	2.31	0.70		0.75	2.84	1/2-20UNF	3.75	0.39	0.63	2.30	3.25	0.28	0.41	NPT1/4	0.33	0.26	3.23	0.69

Series NCQ8

Dimensions/NCQ8B150 to 250-□T (Refer to page 44 for both ends tapped and male thread dimensions.)

150 (1-1/2"), 200 (2"), 250 (2-1/2")

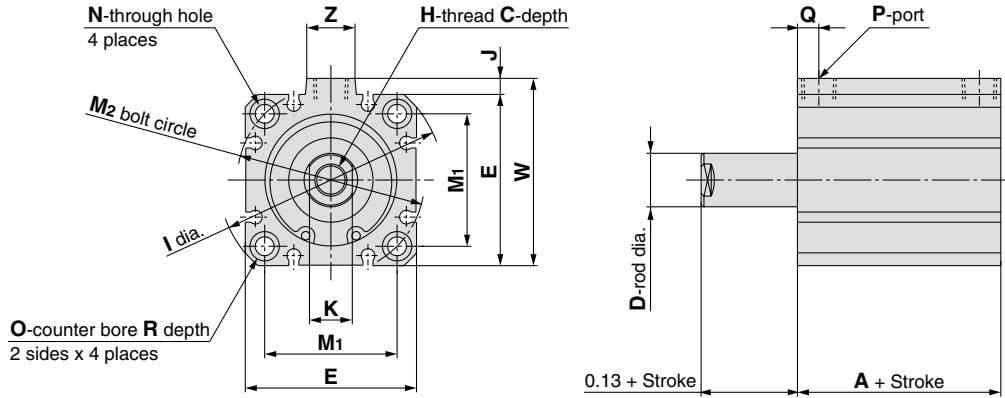

(Inch)

Symbol	A		C		D	E	H	I	J	K	M ₁	M ₂	N	O	P	Q	R	W	Z
	1/8" to 1"st	1-1/4" to 2"st	1/8"st	1/4"st															
150 (1-1/2")	1.38	2.00	0.50	0.70	0.63	2.00	3/8-24UNF	2.63	0.19	0.50	1.55	2.19	0.22	0.34	NPT1/8	0.25	0.20	2.19	0.56
200 (2")	1.44	2.06	0.44	0.70	0.75	2.53	1/2-20UNF	3.13	0.20	0.63	1.90	2.69	0.22	0.34	NPT1/8	0.25	0.20	2.73	0.56
250 (2-1/2")	1.94	2.81	0.44	0.70	0.75	2.84	1/2-20UNF	3.75	0.39	0.63	2.30	3.25	0.28	0.41	NPT1/4	0.33	0.26	3.23	0.69

Compact Cylinder Single Acting, Single Rod **Series NCQ8**

Dimensions/NCDQ8B056 to 106-□T (Refer to page 44 for both ends tapped and male thread dimensions.)

056 (9/16")

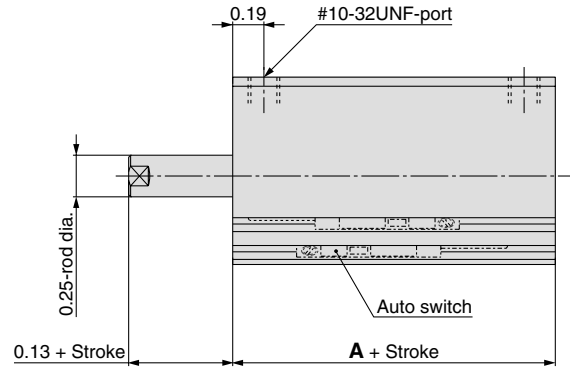
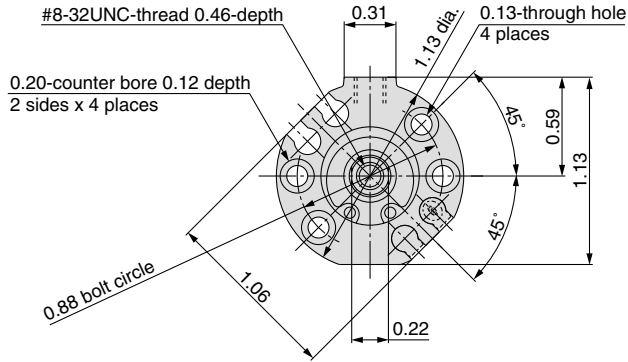

(Inch)

Symbol	A
Stroke	
1/4" to 1"	1.44
1 1/4" to 2"	2.00

075 (3/4"), 106 (1-1/16")

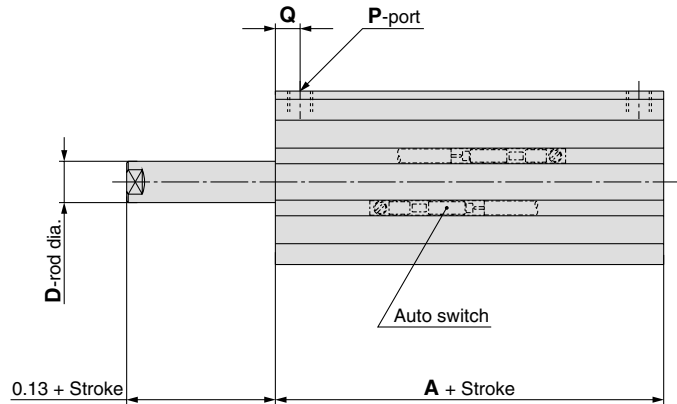
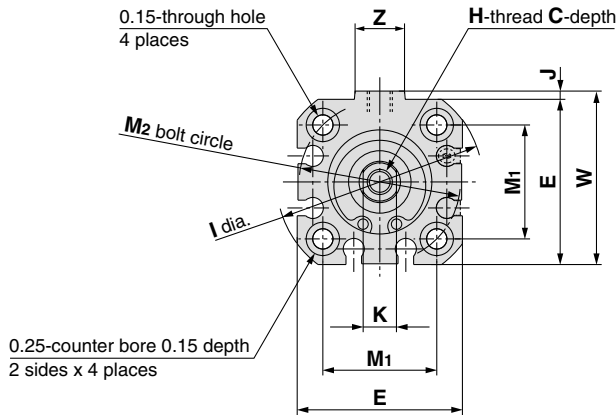

(Inch)

Symbol	A		C	D	E	H	I	J	K	M ₁	M ₂	P	Q	W	Z
	1/4" to 1"st	1-1/4" to 2"st													
Bore															
075 (3/4")	1.94	2.50	0.46	0.31	1.25	#10-32UNF	1.56	0.06	0.25	0.86	1.22	#10-32UNF	0.19	1.31	0.38
106 (1-1/16")	2.25	2.88	0.70	0.50	1.56	5/16-24UNF	2.03	0.16	0.44	1.19	1.69	NPT1/8	0.25	1.72	0.56

Series NCQ8

Dimensions/NCQ8B150 to 250-□T (Refer to page 44 for both ends tapped and male thread dimensions.)

150 (1-1/2"), 200 (2"), 250 (2-1/2")

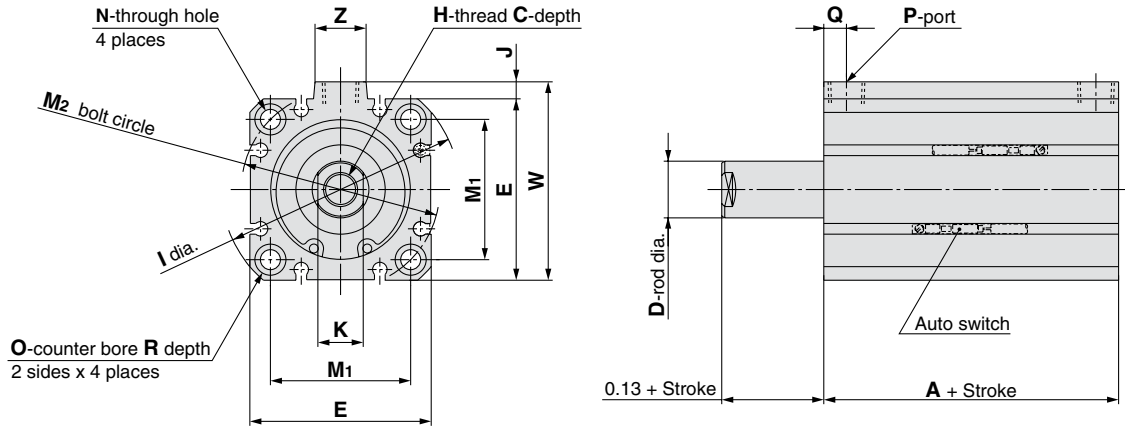

(Inch)

Symbol Bore	A		C	D	E	H	I	J	K	M ₁	M ₂	N	O	P	Q	R	W	Z
	1/4" to 1"st	1-1/4" to 2"st																
150 (1-1/2")	2.25	2.88	0.70	0.63	2.00	3/8-24UNF	2.63	0.19	0.50	1.55	2.19	0.22	0.34	NPT1/8	0.25	0.20	2.19	0.56
200 (2")	2.31	2.94	0.70	0.75	2.53	1/2-20UNF	3.13	0.20	0.63	1.90	2.69	0.22	0.34	NPT1/8	0.25	0.20	2.73	0.56
250 (2-1/2")	2.81	3.69	0.70	0.75	2.84	1/2-20UNF	3.75	0.39	0.63	2.30	3.25	0.28	0.41	NPT1/4	0.33	0.26	3.23	0.69

Compact Cylinder Single Acting, Single Rod **Series NCQ8**

Dimensions/NCDQ8BZ056 to 106-□T (Refer to page 44 for both ends tapped and male thread dimensions.)

056 (9/16")

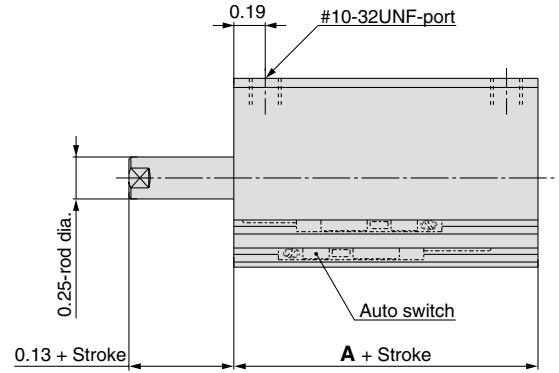
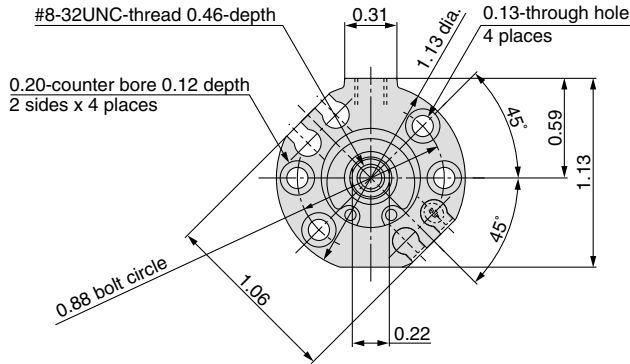

(Inch)	
Symbol	A
Stroke	
1/4" to 1"	1.31
1 1/4" to 2"	1.88

075 (3/4"), 106 (1-1/16")

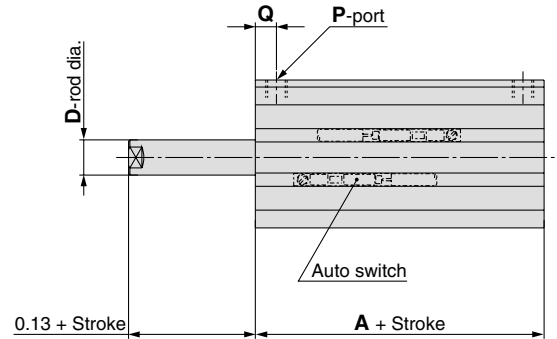
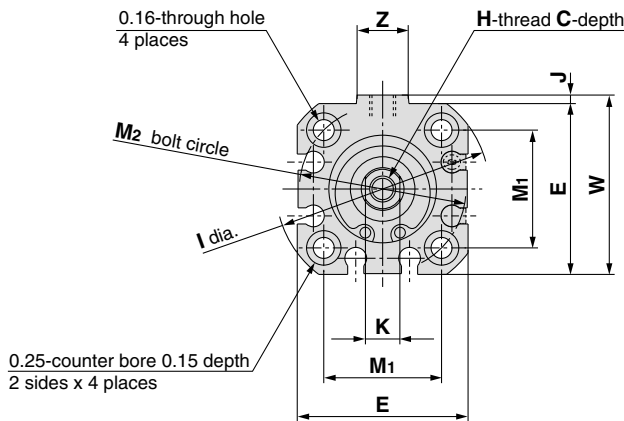

		(Inch)															
Bore	Symbol	A		C		D	E	H	I	J	K	M ₁	M ₂	P	Q	W	Z
		1/4" to 1"st	1-1/4 to 2"st	1/4"st	3/8" to 2"st												
075 (3/4")		1.56	2.13	0.46		0.31	1.25	#10-32UNF	1.56	0.06	0.25	0.86	1.22	#10-32UNF	0.19	1.31	0.38
106 (1-1/16")		1.75	2.38	0.52	0.70	0.50	1.56	5/16-24UNF	2.03	0.16	0.44	1.19	1.69	NPT1/8	0.25	1.72	0.56

Series NCQ8

Dimensions/NCDQ8BZ150 to 250-□T (Refer to page 44 for both ends tapped and male thread dimensions.)

150 (1-1/2"), 200 (2"), 250 (2-1/2")

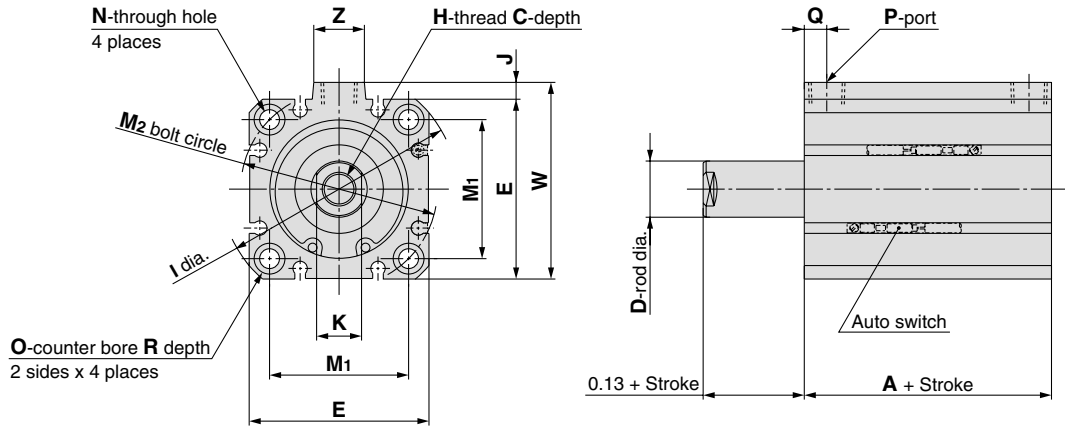

Symbol	A		C		D	E	H	I	J	K	M ₁	M ₂	N	O	P	Q	R	W	Z
	1/4" to 1"st	1-1/4 to 2"st	1/4"st	3/8" to 2"st															
150 (1-1/2")	1.75	2.38	0.50	0.70	0.63	2.00	3/8-24UNF	2.63	0.19	0.50	1.55	2.19	0.22	0.34	NPT1/8	0.25	0.20	2.19	0.56
200 (2")	1.69	2.31	0.70		0.75	2.53	1/2-20UNF	3.13	0.20	0.63	1.90	2.69	0.22	0.34	NPT1/8	0.25	0.20	2.73	0.56
250 (2-1/2")	2.19	3.06	0.70		0.75	2.84	1/2-20UNF	3.75	0.39	0.63	2.30	3.25	0.28	0.41	NPT1/4	0.33	0.26	3.23	0.69

(Inch)

Compact Cylinder Single Acting, Single Rod **Series NCQ8**

Dimensions

Rear clevis / NC(D)Q8C(Z) □-□^S_T 056 (9/16")

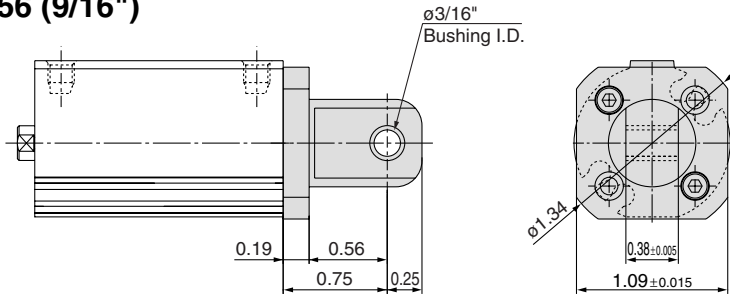

(Inch)

Symbol	CC	CD	CE	CF	CG	CJ
Bore						
075 (3/4")	0.75	0.19	0.56	0.25	3/16"	0.38
106 (1-1/16")	0.81	0.25	0.56	0.25	3/16"	0.38
150 (1-1/2")	1.19	0.25	0.94	0.44	3/8	0.75
200 (2")	1.25	0.31	0.94	0.44	3/8	0.75
250 (2-1/2")	1.31	0.38	0.93	0.44	3/8	0.75

075 (3/4"), 106 (1/6"), 150 (1-1/2"), 200 (2"), 250 (2-1/2")

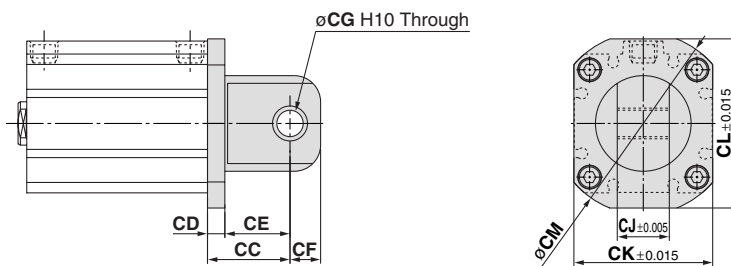

Symbol	CK	CL	CM
Bore			
075 (3/4")	0.86	1.47	1.56
106 (1-1/16")	1.56	1.94	2.03
150 (1-1/2")	2.00	2.44	2.62
200 (2")	1.90	3.00	3.13
250 (2-1/2")	2.30	3.62	3.74

Front screw clearance hole / NC(D)Q8E(Z) □-□^S_T

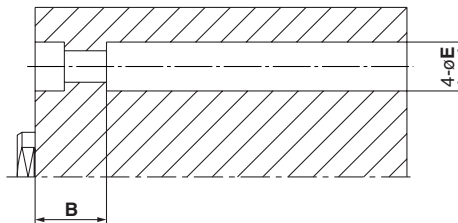

(Inch)

Symbol	B	E
Bore		
056 (9/16")	0.34	0.20
075 (3/4")	0.34	0.25
106 (1-1/16")	0.50	0.25
150 (1-1/2")	0.50	0.34
200 (2")	0.53	0.34
250 (2-1/2")	0.66	0.41

Rear screw clearance hole / NC(D)Q8M(Z) □-□^S_T

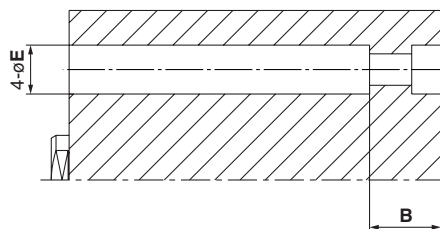

(Inch)

Symbol	B	E
Bore		
056 (9/16")	0.34	0.20
075 (3/4")	0.34	0.25
106 (1-1/16")	0.50	0.25
150 (1-1/2")	0.50	0.34
200 (2")	0.53	0.34
250 (2-1/2")	0.66	0.41

Through screw clearance hole / NC(D)Q8N(Z) □-□^S_T

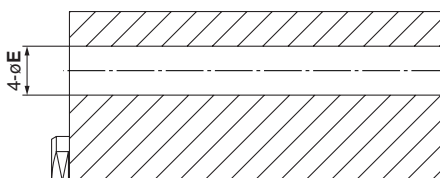

(Inch)

Symbol	E
Bore	
056 (9/16")	0.20
075 (3/4")	0.25
106 (1-1/16")	0.25
150 (1-1/2")	0.34
200 (2")	0.34
250 (2-1/2")	0.41

Series NCQ8

Dimension

Both ends tapped

NC(D)Q8A□□-□(C)(M)

NC(D)Q8WA□□-□(C)(M)

NC(D)Q8A□□-□S(M)

NC(D)Q8A□□-□T(M)

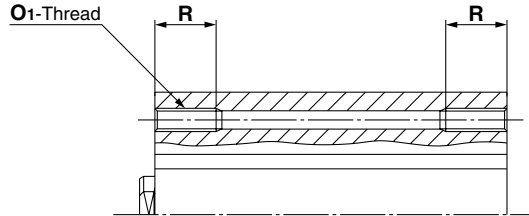

Both Ends Tapped

(Inch)

Bore size	O ₁	R	Remarks
056 (9/16")	#4-40UNC	0.34	Through tap for NCQ8A056-012(C)
075 (3/4")	#6-32UNC	0.34	Through tap for NCQ8A075-012(C)
106 (1-1/16")	#6-32UNC	0.50	Through tap for NCQ8A106-012(C)
150 (1-1/2")	#10-24UNC	0.50	Through tap for NCQ8A150-012(C)
200 (2")	#10-24UNC	0.53	Through tap for NCQ8A200-012(C)
250 (2-1/2")	1/4-20UNC	0.65	Through tap for NCQ8A250-012(C)

Male rod end

NC(D)Q8□□□-□(C)M

NC(D)Q8W□□□-□(C)M

NC(D)Q8□□□-□SM

NC(D)Q8□□□-□TM

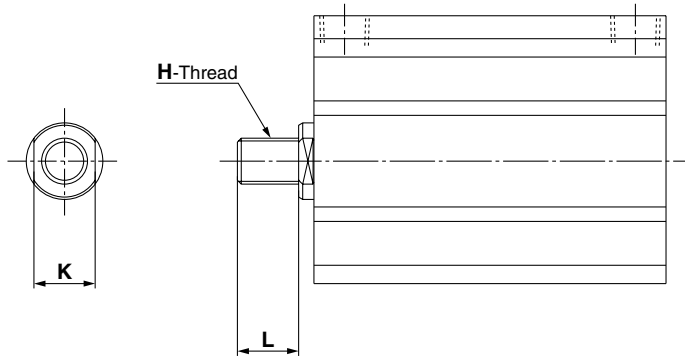

Male Rod End

(Inch)

Bore size	H	L	K
056 (9/16")	#8-32UNC	0.38	0.22
075 (3/4")	#10-32UNF	0.38	0.25
106 (1-1/16")	5/16-24UNF	0.50	0.44
150 (1-1/2")	3/8-24UNF	0.50	0.50
200 (2")	1/2-20UNF	0.63	0.63
250 (2-1/2")	1/2-20UNF	0.63	0.63

Accessories

Single Rod Clevis (Rod eye)

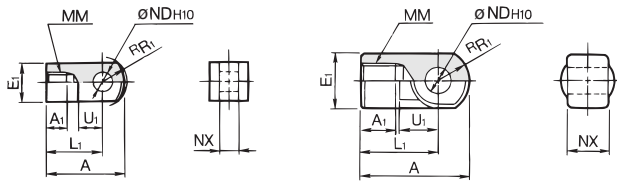

Material: Carbon steel

Material: Cast iron

inch

Part no.	Applicable bore size	A	A ₁	E ₁	L ₁	MM	^R R ₁	U ₁	ND _{H10}	NX
RCS-015	056 (9/16")	1.26	0.24	0.47	0.98	#8-32UNC	0.47	0.55	3/16 ^{+0.002} ₀	0.25 ^{-0.002} ₀
RCS-02	075 (3/4")	1.34	0.24	0.63	0.98	#10-32UNF	0.41	0.45	5/16 ^{+0.002} ₀	0.31 ^{-0.008} ₀
RCS-03	106 (1-1/16")	1.65	0.63	0.87	1.18	5/16-24UNF	0.47	0.55	3/8 ^{+0.002} ₀	0.71 ^{-0.012} ₀
RCS-04	150 (1-1/2")	1.65	0.63	0.87	1.18	3/8-24UNF	0.47	0.55	3/8 ^{+0.002} ₀	0.71 ^{-0.012} ₀
RCS-05	200 (2"), 250 (2-1/2")	2.20	0.71	1.10	1.57	1/2-20UNF	0.63	0.79	1/2 ^{+0.002} ₀	0.87 ^{-0.012} ₀

Double Rod Clevis (Rod eye)

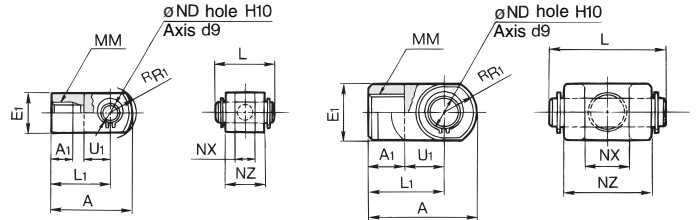

Material: Carbon steel

Material: Cast iron

inch

Part no.	Applicable bore size	A	A ₁	E ₁	L ₁	MM	^R R ₁	U ₁	ND _{H10}	NX	NZ	L
RCD-015	056 (9/16")	1.10	0.24	0.47	0.83	#8-32UNC	0.47	0.39	3/16 ^{+0.002} ₀	0.26 ^{-0.008} ₀	0.47	0.63
RCD-02	075 (3/4")	1.34	0.24	0.63	0.98	#10-32UNF	0.41	0.45	5/16 ^{+0.002} ₀	0.31 ^{-0.008} ₀	0.63	0.83
RCD-03	106 (1-1/16")	1.65	0.63	0.87	1.18	5/16-24UNF	0.47	0.55	3/8 ^{+0.002} ₀	0.71 ^{-0.012} ₀	1.42	1.61
RCD-04	150 (1-1/2")	1.65	0.63	0.87	1.18	3/8-24UNF	0.47	0.55	3/8 ^{+0.002} ₀	0.71 ^{-0.012} ₀	1.42	1.61
RCD-05	200 (2"), 250 (2-1/2")	2.20	0.79	1.10	1.57	1/2-20UNF	0.63	0.79	1/2 ^{+0.002} ₀	0.87 ^{-0.012} ₀	1.73	1.97

* Clevis Pin and Snap rings not Included.

Double Rod Clevis Pin

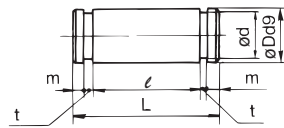

Material: Carbon steel
inch

Part no.	Applicable bore size	Dd9	L	d	l	m	t
PS-015	056 (9/16")	3/16 ^{-0.030} _{-0.060}	0.63	0.175	0.48	0.057	0.018
PS-02	075 (3/4")	5/16 ^{-0.040} _{-0.076}	0.827	0.29	0.64	0.065	0.029
PS-03	106 (1-1/16"), 150 (1-1/2")	3/8 ^{-0.040} _{-0.076}	1.614	0.352	1.43	0.065	0.029
PS-05	200 (2"), 250 (2-1/2")	1/2 ^{-0.050} _{-0.076}	1.969	0.468	1.74	0.075	0.039

Jam Nut

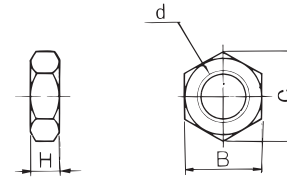

Material: Carbon steel
inch

Part no.	Applicable bore size	d	H	B	C
JM-01	056 (9/16")	#8-32UNC	0.13	0.34	0.39
JM-02	075 (3/4")	#10-32UNF	0.13	0.37	0.43
JM-03	106 (1-1/16")	5/16-24UNF	0.19	0.50	0.58
JM-04	150 (1-1/2")	3/8-24UNF	0.22	0.56	0.65
JM-05	200 (2"), 250 (2-1/2")	1/2-20UNF	0.31	0.75	0.87

Kits

Single Rod Clevis (Rod eye)

Kit no.	Applicable bore size	Including		
		Clevis (1)	Pin (1)	Snap rings (2)
RCSK-015	056 (9/16")	RCS-015	PS-015	PC-01
RCSK-02	075 (3/4")	RCS-02	PS-02	PC-02
RCSK-03	106 (1-1/16")	RCS-03	PS-03	PC-03
RCSK-04	150 (1-1/2")	RCS-04	PS-03	PC-03
RCSK-05	200 (2"), 250 (2-1/2")	RCS-05	PS-05	PC-05

Double Rod Clevis (Rod eye)

Kit no.	Applicable bore size	Including		
		Clevis (1)	Pin (1)	Snap rings (2)
RCDK-015	056 (9/16")	RCD-015	PS-015	PC-01
RCDK-02	075 (3/4")	RCD-02	PS-02	PC-02
RCDK-03	106 (1-1/16")	RCD-03	PS-03	PC-03
RCDK-04	150 (1-1/2")	RCD-04	PS-03	PC-03
RCDK-05	200 (2"), 250 (2-1/2")	RCD-05	PS-05	PC-05

Rod Clevis Pin

Kit no.	Applicable bore size	Including	
		Pin (1)	Snap rings (2)
PRA-015	056 (9/16")	PS-015	PC-01
PRA-02	075 (3/4")	PS-02	PC-02
PRA-03	106 (1-1/16"), 150 (1-1/2")	PS-03	PC-03
PRA-05	200 (2"), 250 (2-1/2")	PS-05	PC-05

Series NCQ8

Made to Order Specifications

Please contact SMC for detailed dimensions, specifications, and lead times.



-XC4: With heavy duty scraper

This cylinder is suitable for use in areas with heavy dust or particulates. It uses a heavy duty wiper ring to scrape debris from the piston rod.

How to Order

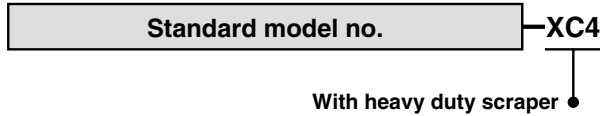

⚠ Caution

Other dimensions are the same as NCQ8/standard type.

Single rod

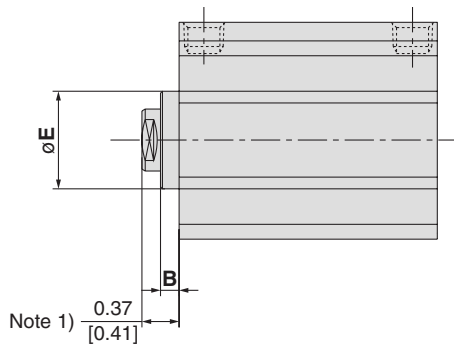

Double rod

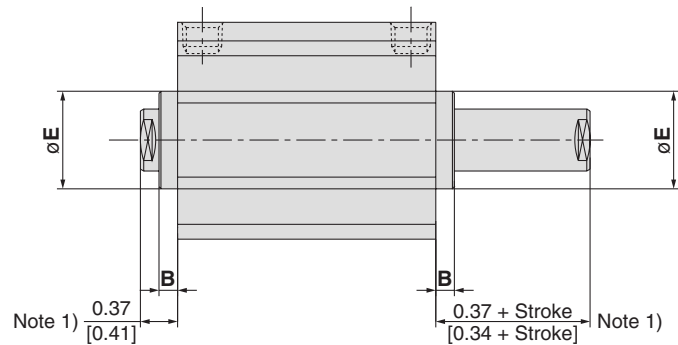

Bore size	B	E
056 (9/16")	0.11	0.44
075 (3/4")	0.18	0.62
106 (1-1/16")	0.17	0.83
150 (1-1/2")	0.19	0.98
200 (2")	0.19	1.13
250 (2-1/2")	0.19	1.13

(Inch)

Bore size	B	E
056 (9/16")	0.11	0.44
075 (3/4")	0.18	0.62
106 (1-1/16")	0.17	0.83
150 (1-1/2")	0.19	0.98
200 (2")	0.19	1.13
250 (2-1/2")	0.19	1.13

(Inch)

Note 1) According to the rubber bumper type, its stroke is reduced by 0.06", and the projection of a piston rod is 0.41" [0.34" + Stroke].

-XB6: Heat resistant (15 to 300°F)

The grease and seal materials are changed so that this cylinder can be used at high temperatures up to 300°F (150°C).

How to Order

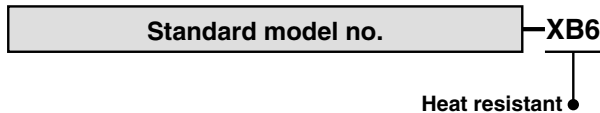

Specifications

Ambient temperature range	15 to 300°F (−10 to 150°C)
Seals material	Fluoro rubber
Grease	Heat resistant grease
Additional specifications Dimensions	Same as standard type



Note 1) Operate without lubrication from a pneumatic system lubricator.

Note 2) Please contact SMC for details on the maintenance intervals for this cylinder, which differ from those of the standard cylinder.

Note 3) Built-in magnet type is not available with this option. Please contact SMC, if those combination is needed. High temp. auto switch may be applicable to certain case.

Note 4) Piston speed is ranged from 2 to 20 in/sec.

Note 5) With rubber bumper excluded.

⚠ Warning

Operating Precautions

Be aware that smoking cigarettes, etc. after your hands have come into contact with the grease used in this cylinder can create a gas that is hazardous to humans.

Auto Switch Mounting

To mount auto switches, follow the instruction illustrated below.

056 to 250/Direct mounting

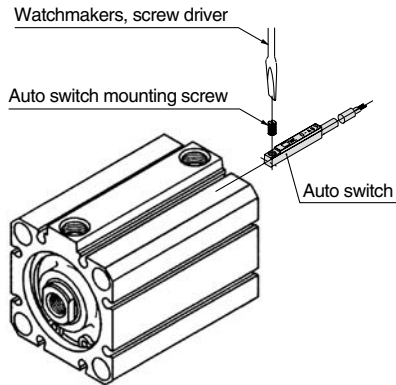

- Use a watchmakers, screwdriver with a handle 0.2" to 0.24"(5 to 6 mm) in diameter when tightening the auto switch mounting screw. Tightening torque should be set 0.08 to 0.15 ft lbs.

The number of surfaces and grooves where an auto switch can be mounted (as direct mounting).

The number of the surfaces and grooves where the auto switch can be mounted, by switch type, are shown in the table below.

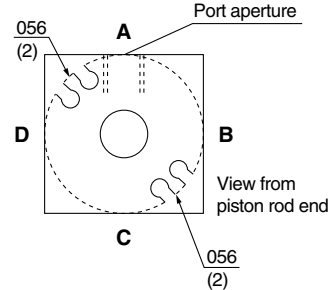

Switch type	D-A9□, M9□, F9□W			
	A (Mounting groove no.)	B (Mounting groove no.)	C (Mounting groove no.)	D (Mounting groove no.)
056 (9/16")	Refer to picture above.			
075 (3/4")	—	○ (2)	○ (2)	○ (2)
106 (1-1/16")	—	○ (2)	○ (2)	○ (2)
150 (1-1/2")	○ (2)	○ (2)	○ (2)	○ (2)
200 (2")	○ (2)	○ (2)	○ (2)	○ (2)
250 (2-1/2")	○ (2)	○ (2)	○ (2)	○ (2)

Operating Range

Auto switch model	Bore size (in)					
	056	075	106	150	200	250
D-F9□W, D-F9□WV, D-F9BAL	0.10	0.12	0.16	0.17	0.19	0.19
D-A9□(V)	0.30	0.30	0.35	0.35	0.35	0.41
D-M9□(V)	0.08	0.09	0.10	0.12	0.14	0.12

* The operating ranges are provided as guidelines including hystereses and are not guaranteed values (assuming approximately ±30% variations). They may vary significantly with ambient environments.

Minimum Auto Switch Mounting Stroke

Model	No. of auto switches	(inch)				
		D-A9□	D-A9□V	D-M9□, D-F9□W	D-M9□V, D-F9□WV	D-F9BAL
NCDQ8A(B)□□(C)(M) NCDQ8A(B)□□-100S(M) NCDQ8A(B)□□-200S(M) NCDQ8A(B)W□□(C)(M) NCDQ8A(B)Z□□(M)	1	0.62 (5/8")	0.25 (1/4")	0.62 (5/8")	0.25 (1/4")	1.00 (1")
NCDQ8A(B)Z□□-100S(M) NCDQ8A(B)Z□□-200S(M) NCDQ8A(B)Z□□-100T(M) NCDQ8A(B)Z□□-200T(M)	2	0.62 (5/8")	0.37(3/8")	0.62 (5/8")	0.25 (1/4")	1.00 (1")
NCDQ8A(B)□□-100T(M) NCDQ8A(B)□□-200T(M)	1	0.37 (3/8")	0.25 (1/4")	0.37 (3/8")	0.25 (1/4")	0.87 (7/8")
	2	0.37 (3/8")	0.37 (3/8")	0.37 (3/8")	0.25 (1/4")	0.87 (7/8")

Series NCQ8

Auto Switches/Proper Mounting Positions and Height for Stroke End Detection

Reed switch
D-A9□(V)

056

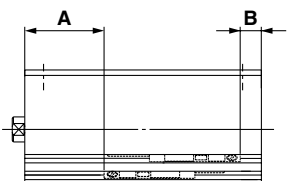

075, 106

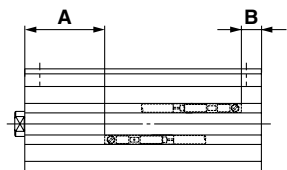

150, 200, 250

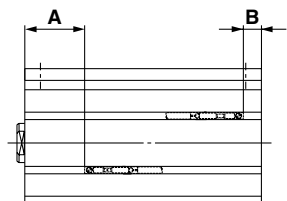

Solid state switch
D-M9□(V)
D-F9□W(V)

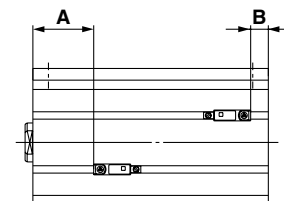
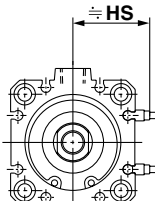
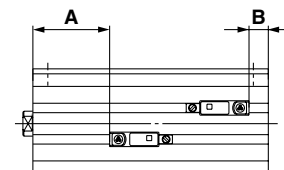
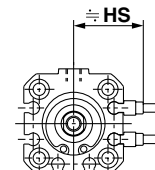
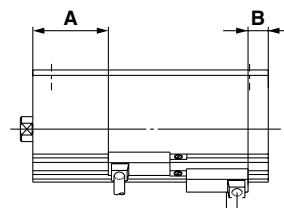
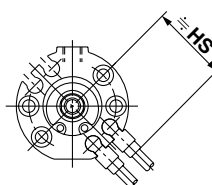

Note 1) Figures in the table below are references for auto switch mounting positions in the stroke end detection. In an actual setting, confirm the auto switch operating conditions, then adjust it.

NCDQ8A(B)□-□(C)(M) (in)

Bore size	D-A9□, D-A9□V			D-M9□(V), D-F9□W(V)			D-F9BAL		
	A	B	HS	A	B	HS	A	B	HS
056	0.61	0.04	0.71	0.77	0.2	0.79	0.73	0.16	0.69
075	0.55	0.08	0.81	0.71	0.24	0.89	0.67	0.2	0.79
106	0.85	0.12	0.96	1	0.28	1.04	0.96	0.24	0.94
150	0.83	0.12	1.18	0.98	0.28	1.26	0.94	0.24	1.16
200	0.81	0.2	1.45	0.96	0.35	1.52	0.93	0.31	1.43
250	0.98	0.28	1.6	1.14	0.43	1.68	1.1	0.39	1.58

NCDQ8A(B)□-100T(M) (025st to 100st) (in)

Bore size	D-A9□, D-A9□V			D-M9□(V), D-F9□W(V)			D-F9BAL		
	A	B	HS	A	B	HS	A	B	HS
056	0.24	0.41	0.71	0.39	0.57	0.79	0.35	0.53	0.69
075	0.55	0.59	0.81	0.71	0.75	0.89	0.67	0.71	0.79
106	0.85	0.61	0.96	1	0.77	1.04	0.96	0.73	0.94
150	0.83	0.63	1.18	0.98	0.79	1.26	0.94	0.75	1.16
200	0.81	0.69	1.45	0.96	0.85	1.52	0.93	0.81	1.43
250	0.98	1.02	1.6	1.14	1.18	1.68	1.1	1.14	1.58

NCDQ8A(B)□-100S(M) (025st to 100st) (in)

Bore size	D-A9□, D-A9□V			D-M9□(V), D-F9□W(V)			D-F9BAL		
	A	B	HS	A	B	HS	A	B	HS
056	0.59	0.04	0.71	0.75	0.2	0.79	0.71	0.16	0.69
075	0.81	0.08	0.81	0.96	0.24	0.89	0.93	0.2	0.79
106	0.83	0.12	0.96	0.98	0.28	1.04	0.94	0.24	0.94
150	0.83	0.12	1.18	0.98	0.28	1.26	0.94	0.24	1.16
200	0.81	0.2	1.45	0.96	0.35	1.52	0.93	0.31	1.43
250	0.98	0.28	1.6	1.14	0.43	1.68	1.1	0.39	1.58

NCDQ8A(B)□-200T(M) (125st to 200st) (in)

Bore size	D-A9□, D-A9□V			D-M9□(V), D-F9□W(V)			D-F9BAL		
	A	B	HS	A	B	HS	A	B	HS
056	0.24	0.98	0.71	0.39	1.14	0.79	0.35	1.1	0.69
075	0.55	1.14	0.81	0.71	1.3	0.89	0.67	1.26	0.79
106	0.85	1.24	0.96	1	1.4	1.04	0.96	1.36	0.94
150	0.83	1.26	1.18	0.98	1.42	1.26	0.94	1.38	1.16
200	0.81	1.32	1.45	0.96	1.48	1.52	0.93	1.44	1.43
250	0.98	1.89	1.6	1.14	2.05	1.68	1.1	2.01	1.58

NCDQ8A(B)□-200S(M) (125st to 200st) (in)

Bore size	D-A9□, D-A9□V			D-M9□(V), D-F9□W(V)			D-F9BAL		
	A	B	HS	A	B	HS	A	B	HS
056	1.16	0.04	0.71	1.32	0.2	0.79	1.28	0.16	0.69
075	1.38	0.08	0.81	1.54	0.24	0.89	1.5	0.2	0.79
106	1.46	0.12	0.96	1.61	0.28	1.04	1.57	0.24	0.94
150	1.44	0.12	1.18	1.59	0.28	1.26	1.56	0.24	1.16
200	1.44	0.2	1.45	1.59	0.35	1.52	1.56	0.31	1.43
250	1.85	0.28	1.6	2.01	0.43	1.68	1.97	0.39	1.58

NCDQ8A(B)W□-□(C)(M) (in)

Bore size	D-A9□, D-A9□V			D-M9□(V), D-F9□W(V)			D-F9BAL		
	A	B	HS	A	B	HS	A	B	HS
056	0.69	0.1	0.71	0.85	0.26	0.79	0.81	0.22	0.69
075	0.63	0.16	0.81	0.79	0.31	0.89	0.75	0.28	0.79
106	0.51	0.51	0.96	0.67	0.67	1.04	0.63	0.63	0.94
150	0.55	0.55	1.18	0.71	0.71	1.26	0.67	0.67	1.16
200	0.57	0.57	1.45	0.73	0.73	1.52	0.69	0.69	1.43
250	0.69	0.69	1.6	0.85	0.85	1.68	0.81	0.81	1.58

Auto Switches/Proper Mounting Positions and Height for Stroke End Detection

Reed switch
D-A9□(V)

056

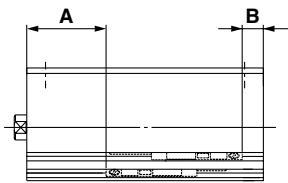

075, 106

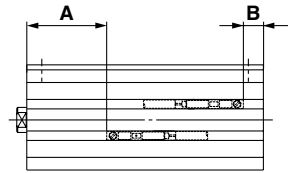

150, 200, 250

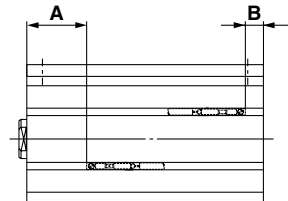

Solid state switch
D-M9□(V)
D-F9□W(V)

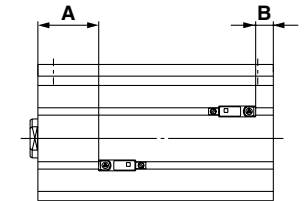
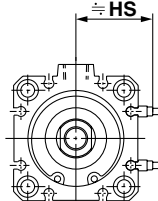
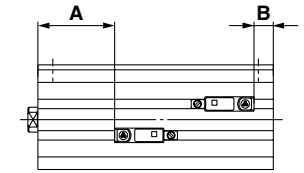
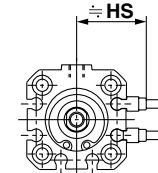
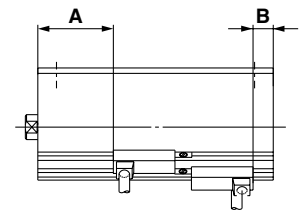
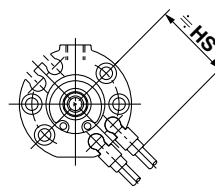

Note 1) Figures in the table below are references for auto switch mounting positions in the stroke end detection. In an actual setting, confirm the auto switch operating conditions, then adjust it.

NCDQ8A(B)Z□-□(C)(M) (in)

Bore size	D-A9□, D-A9□V			D-M9□(V), D-F9□W(V)			D-F9BAL		
	A	B	HS	A	B	HS	A	B	HS
056	0.24	0.04	0.71	0.39	0.2	0.79	0.35	0.16	0.69
075	0.14	0.08	0.81	0.3	0.24	0.89	0.26	0.2	0.79
106	0.33	0.12	0.96	0.49	0.28	1.04	0.45	0.24	0.94
150	0.31	0.12	1.18	0.47	0.28	1.26	0.43	0.24	1.16
200	0.2	0.2	1.45	0.35	0.35	1.52	0.31	0.31	1.43
250	0.35	0.28	1.6	0.51	0.43	1.68	0.47	0.39	1.58

NCDQ8A(B)Z□-100T(M) (025st to 100st) (in)

Bore size	D-A9□, D-A9□V			D-M9□(V), D-F9□W(V)			D-F9BAL		
	A	B	HS	A	B	HS	A	B	HS
056	0.12	0.41	0.71	0.28	0.57	0.79	0.24	0.53	0.69
075	0.18	0.59	0.81	0.33	0.75	0.89	0.3	0.71	0.79
106	0.33	0.61	0.96	0.49	0.77	1.04	0.45	0.73	0.94
150	0.31	0.63	1.18	0.47	0.79	1.26	0.43	0.75	1.16
200	0.2	0.69	1.45	0.35	0.85	1.52	0.31	0.81	1.43
250	0.35	1.02	1.6	0.51	1.18	1.68	0.47	1.14	1.58

NCDQ8A(B)Z□-100S(M) (025st to 100st) (in)

Bore size	D-A9□, D-A9□V			D-M9□(V), D-F9□W(V)			D-F9BAL		
	A	B	HS	A	B	HS	A	B	HS
056	0.35	0.04	0.71	0.51	0.2	0.79	0.47	0.16	0.69
075	0.31	0.08	0.81	0.47	0.24	0.89	0.43	0.2	0.79
106	0.33	0.12	0.96	0.49	0.28	1.04	0.45	0.24	0.94
150	0.31	0.12	1.18	0.47	0.28	1.26	0.43	0.24	1.16
200	0.18	0.2	1.45	0.33	0.35	1.52	0.3	0.31	1.43
250	0.35	0.28	1.6	0.51	0.43	1.68	0.47	0.39	1.58

NCDQ8A(B)Z□-200T(M) (125st to 200st) (in)

Bore size	D-A9□, D-A9□V			D-M9□(V), D-F9□W(V)			D-F9BAL		
	A	B	HS	A	B	HS	A	B	HS
056	0.12	0.98	0.71	0.28	1.14	0.79	0.24	1.1	0.69
075	0.18	1.14	0.81	0.33	1.3	0.89	0.3	1.26	0.79
106	0.33	1.24	0.96	0.49	1.4	1.04	0.45	1.36	0.94
150	0.31	1.26	1.18	0.47	1.42	1.26	0.43	1.38	1.16
200	0.2	1.32	1.45	0.35	1.48	1.52	0.31	1.44	1.43
250	0.35	1.89	1.6	0.51	2.05	1.68	0.47	2.01	1.58

NCDQ8A(B)Z□-200S(M) (125st to 200st) (in)

Bore size	D-A9□, D-A9□V			D-M9□(V), D-F9□W(V)			D-F9BAL		
	A	B	HS	A	B	HS	A	B	HS
056	0.91	0.04	0.71	1.06	0.2	0.79	1.02	0.16	0.69
075	0.87	0.08	0.81	1.02	0.24	0.89	0.98	0.2	0.79
106	0.96	0.12	0.96	1.12	0.28	1.04	1.08	0.24	0.94
150	0.94	0.12	1.18	1.1	0.28	1.26	1.06	0.24	1.16
200	0.81	0.2	1.45	0.96	0.35	1.52	0.93	0.31	1.43
250	1.22	0.28	1.6	1.38	0.43	1.68	1.34	0.39	1.58

Series NCQ8

Auto Switch Specifications

Auto Switch Common Specifications

Type	Reed switches	Solid state switches
Leakage current	None	3-wire: 100 μ A or less, 2-wire: 0.8 mA or less
Operating time	1.2 ms	1 ms or less
Impact resistance	984 ft/s ²	3280 ft/s ²
Insulation resistance	50 M Ω or more at 500 VDC (between lead wire and case)	
Withstand voltage	1000 VAC for 1 min. (between lead wire and case)	1000 VAC for 1 min. (between lead wire and case)
Ambient temperature	14 to 140°F (-10 to 60°C)	
Enclosure	IEC529 standard IP67, watertight (JIS C 0920)	

Lead Wire Length

Lead wire length indication

(Example) **D-M9P** **L**

Lead wire length

Nil	20 in (0.5 m)
L	118 in (3 m)
Z	197 in (5 m)

- Note 1) Lead wire length Z: 197 in applicable auto switches
 Reed switch: To be dealt with specially
 Solid state switch: All types are produced upon receipt of order.
- Note 2) The standard lead wire length of solid state switch with timer or with tight water 2-color display is 118" (3 m). (Not available 20" (0.5 m))
- Note 3) For solid state switches with flexible wire specification, add "-61" at the end of the lead wire length.
- Note 4) Robot cable is available as standard for D-M9□.

(Example) **D-F9PWVL-61**

Flexible specification

Auto Switch Hysteresis

Hysteresis is the distance between the position at which piston movement operates an auto switch to the position at which reverse movement turns the switch off. This hysteresis is included in part of the operating range (one side).

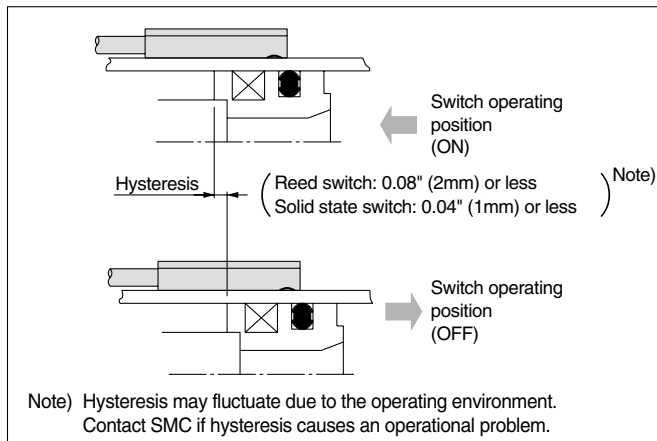

Contact Protection Box/CD-P11, CD-P12

Applicable switch type

D-A9 and D-A9□V type switches do not have internal contact protection circuits.

- The operated load is an induction load.
- The length of wiring to the load is 197" (5 m) or more.
- The load voltage is 100 VAC.

A contact protection box should be used in any of the above situations. The lifetime of the contact may be shortened.

Specifications

Part No.	CD-P11		CD-P12
Load voltage	100 VAC	200 VAC	24 VDC
Max. load current	25 mA	12.5 mA	50 mA

* Lead wire length — Switch connection side: 20" (0.5 m)
 Load connection side: 20" (0.5 m)



Internal Circuit

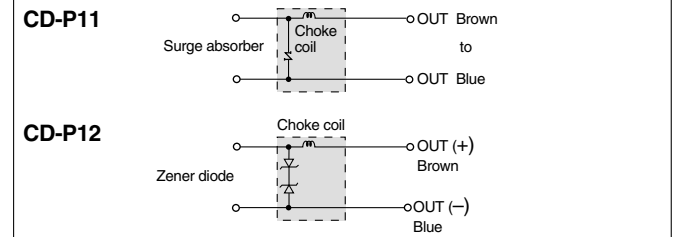

Dimensions

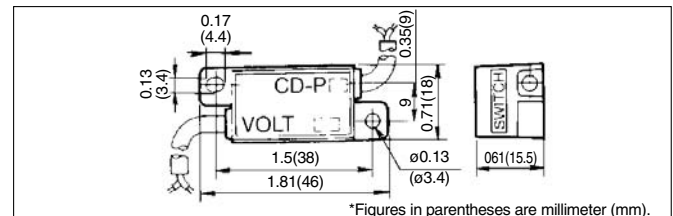

Contact Protection Box/Connection

To connect a switch unit to a contact protection box, connect the lead wire from the side of the contact protection box marked SWITCH to the lead wire coming out of the switch unit. The switch unit should be kept as close as possible to the contact protection box with a lead wire that is no more than 39.37" (1m) in length.

Series NCQ8

Auto Switch Connections and Examples

Basic Wiring

Solid state 3-wire, NPN

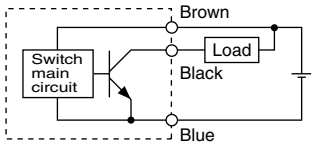

Solid state 3-wire, PNP

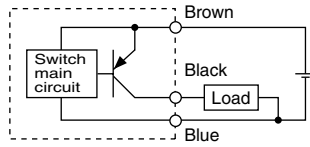

2-wire (Solid state switch)

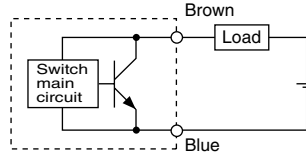

2-wire (Reed switch)

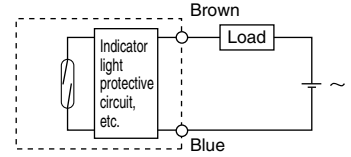

(Power supplies for switch and load are separate)

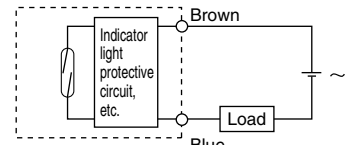
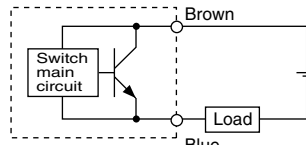
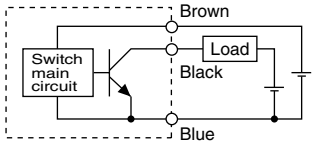

Examples of Connection to PLC (Programable Logic Controller)

• Sink input specifications 3-wire, NPN

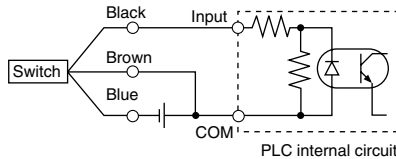

• Source input specifications 3-wire, PNP

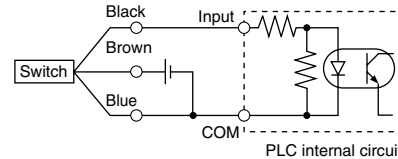

Connect according to the applicable PLC input specifications, as the connection method will vary depending on the PLC input specifications.

2-wire

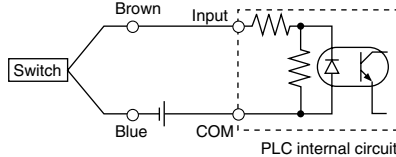

2-wire

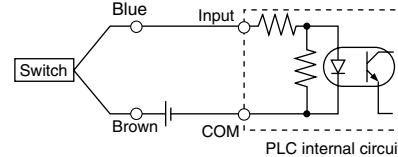

Connection Examples for AND (Series) and OR (Parallel)

• 3-wire (using relays) AND connection for NPN output (using relays)

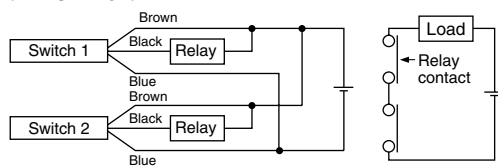

AND connection for NPN output (performed with switches only)

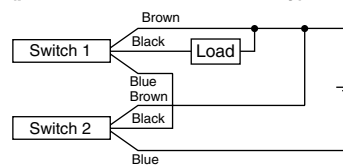

OR connection for NPN output

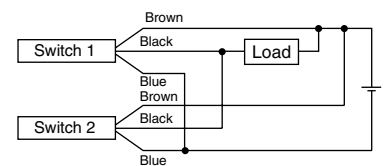

The indicator light illuminates when the two switches are in the ON state.

2-wire with 2-switch AND connection

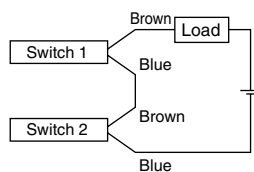

When two switches are connected in series, a load may malfunction because the load voltage will decline when in the ON state. The indicator lights will light when both switches are in the ON state.

Load voltage at ON = Power supply voltage -
Internal voltage drop x 2 pcs.
= 24 V - 4 V x 2 pcs.
= 16 V

Example: Power supply is 24 VDC
Internal voltage drop in switch is 4 V.

2-wire with 2-switch OR connection

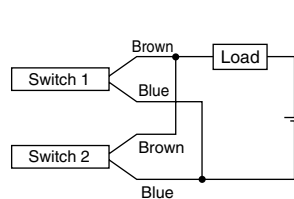

< Solid State >

When two switches are connected in parallel, malfunction may occur because the load voltage will increase when in the OFF state.

Load voltage at OFF = Leakage current x 2 pcs. x
Load impedance
= 1 mA x 2 pcs. x 3 kΩ
= 6 V

Example: Load impedance is 3 kΩ.
Leakage current from switch is 1 mA.

< Reed Switch >

Because there is no current leakage, the load voltage will not increase when turned OFF. However, depending on the number of switches in the ON state, the indicator lights may sometimes grow dim or not light up because of the dispersion and reduction of the current flowing to the switches.

Reed Switch Direct Mounting Style D-A90(V)/D-A93(V)/D-A96(V)



Refer to www.smcworld.com for details of products compatible with overseas standards.

Auto Switch Specification

PLC: Programmable Logic Controller

Grommet Electrical entry: In-line



⚠ Caution

Operating Precautions

- Do not use anything other than the mounting screws attached to the auto switch body to secure the switch. If screws other than those specified are used, it may cause the switch to be damaged.

Auto Switch Internal Circuit

D-A90, A90V

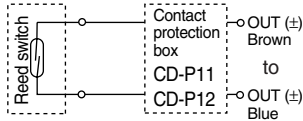

D-A93, A93V

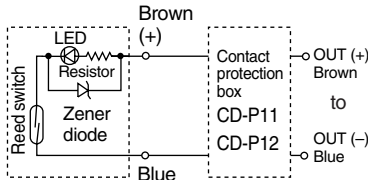

D-A96, A96V

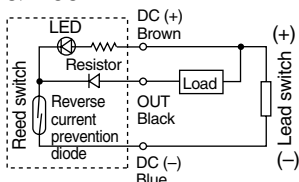

- Note) 1. In the case operation load is an inductive load.
2. In the case the wiring length to load is more than 197" (5m).
3. In the case the load voltage is 100 VAC.

A contact protection box should be used if any of the above conditions is applicable. The lifetime of the contact may be shortened. (For detailed information about the contact protection box, please refer to page 50.)

D-A90, D-A90V (Without indicator light)

Auto switch part no.	D-A90, D-A90V		
Applicable load	IC circuit, Relay, PLC		
Load voltage	24 V _{DC} ^{AC} or less	48 V _{DC} ^{AC} or less	100 V _{DC} ^{AC} or less
Maximum load current	50 mA	40 mA	20 mA
Contact protection circuit	None		
Internal resistance	1 Ω or less (including lead wire length of 118"(3m))		

D-A93, D-A93V, D-A96, D-A96V (With indicator light)

Auto switch part no.	D-A93, D-A93V		D-A96, D-A96V
Applicable load	Relay, PLC		IC
Load voltage	24 VDC	100 VAC	4 to 8 VDC
Load current range and max. load current	5 to 40 mA	5 to 20 mA	20 mA
Contact protection circuit	None		
Internal voltage drop	D-A93 — 2.4 V or less (to 20 mA)/ 3 V or less (to 40 mA) D-A93V — 2.7 V or less		0.8 V or less
Indicator light	Red LED lights up when ON		

● Lead wires

- Oilproof vinyl heavy-duty cord, 0.11" (ø2.7mm), 20" (0.5m)
- D-A90(V), D-A93(V) 2.8 x 10⁻⁴ in² (0.18mm²) x 2 cores (Brown, Blue)
- D-A96(V) 2.3 x 10⁻⁴ in² (0.15mm²) x 3 cores (Brown, Black, Blue)

Note 1) Refer to page 50 for auto switch common specifications.

Note 2) Refer to page 50 for lead wire lengths.

Note 3) Visibility of indicator light decreases under 5 mA, and may be hard to recognize under 2.5 mA. For over 1mA, there should be no problem for contact outputs.

Weight

Unit: OZ, (): g

Model	D-A90	D-A90V	D-A93	D-A93V	D-A96	D-A96V
Lead wire length 30 in (0.5 m)	0.21 (6)	0.21 (6)	0.21 (6)	0.21 (6)	0.28 (8)	0.28 (8)
Lead wire length 118 in (3 m)	1.06 (30)	1.06 (30)	1.06 (30)	1.06 (30)	1.45 (41)	1.45 (41)

Dimensions

Unit: in

(): mm

D-A90, D-A93, D-A96

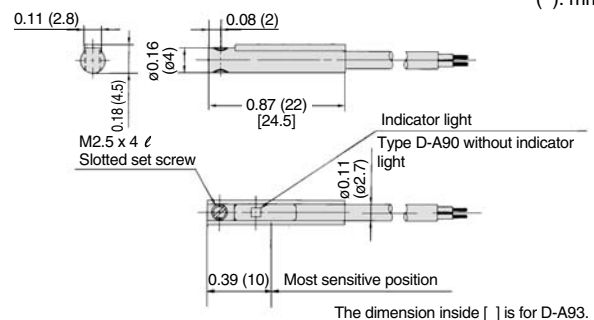

D-A90V, D-A93V, D-A96V

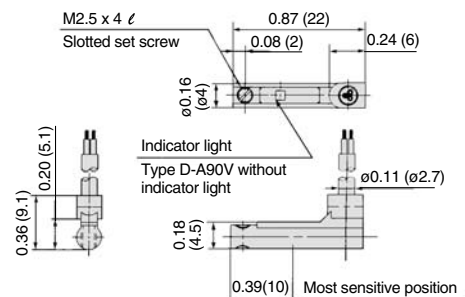

Solid State Switch Direct Mounting Style

D-M9N(V)/D-M9P(V)/D-M9B(V)



For details about certified products conforming to international standards, visit us at www.smcworld.com.

Auto Switch Specifications

PLC: Abbreviation of Programmable Logic Controller

D-M9□, D-M9□V (With indicator light)						
Auto switch model	D-M9N	D-M9NV	D-M9P	D-M9PV	D-M9B	D-M9BV
Electrical entry direction	In-line	Perpendicular	In-line	Perpendicular	In-line	Perpendicular
Wiring type	3-wire			2-wire		
Output type	NPN		PNP		—	
Applicable load	IC circuit, Relay, PLC				24 VDC relay, PLC	
Power supply voltage	5, 12, 24 VDC (4.5 to 28 V)					—
Current consumption	10 mA or less					—
Load voltage	28 VDC or less		—		24 VDC (10 to 28 VDC)	
Load current	40 mA or less				2.5 to 40 mA	
Internal voltage drop	0.8 V or less					4 V or less
Leakage current	100 μA or less at 24 VDC					0.8 mA or less
Indicator light	Red LED lights when ON.					

- Lead wires — Oilproof vinyl heavy-duty cord
0.1" (2.7 mm) x 0.13" (3.2mm) ellipse, 2.3 x 10⁻⁴in² (0.15mm²), 2 cores: D-M9B(V), 3 cores: D-M9N(V), D-M9P(V)
Note 1) Refer to page 50 for solid state switch common specifications.
Note 2) Refer to page 50 for lead wire lengths.

Weight

Unit: OZ, (): g

Auto switch model	D-M9N(V)	D-M9P(V)	D-M9B(V)	
Lead wire length in(m)	20 (0.5)	0.28 (8)	0.28 (8)	0.25 (7)
	118 (3)	1.45 (41)	1.45 (41)	1.34 (38)
	197 (5)	2.40 (68)	2.40 (68)	2.22 (63)

Dimensions

Unit: in

(): mm

D-M9□

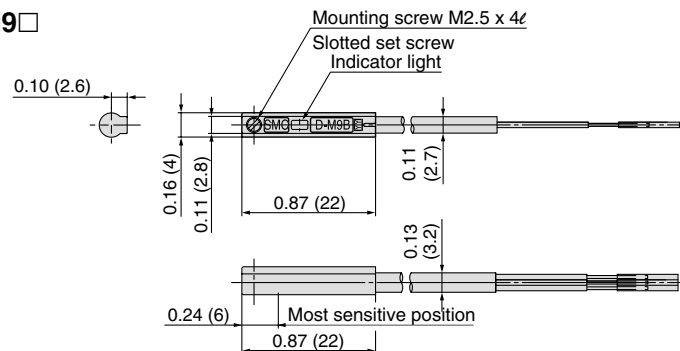

D-M9□V

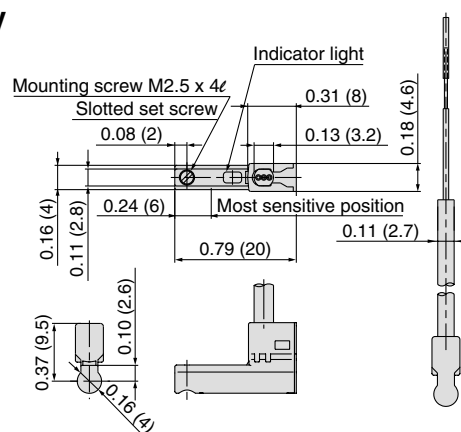

Grommet

- 2-wire load current is reduced (2.5 to 40 mA)
- Lead-free
- UL certified (style 2844) lead cable is used.



Caution

Operating Precautions

Fix the switch with the existing screw installed on the switch body. The switch may be damaged if a screw other than the one supplied, is used.

Auto Switch Internal Circuit

D-M9N, M9NV

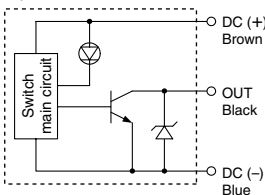

D-M9P, M9PV

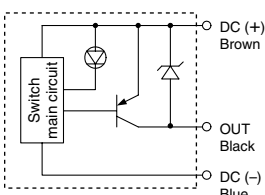

D-M9B, M9BV

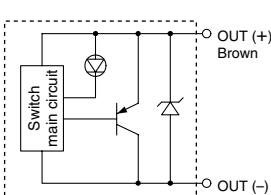

2-color Indication Type Solid State Switch Direct Mounting Style

D-F9NW(V)/D-F9PW(V)/D-F9BW(V)



Refer to www.smcworld.com for details of products compatible with overseas standards.

Auto Switch Specifications

PLC: Programmable Logic Controller

D-F9□W, D-F9□WV (With indicator light)						
Auto switch part no.	D-F9NW	D-F9NWV	D-F9PW	D-F9PWV	D-F9BW	D-F9BWV
Electrical entry direction	In-line	Perpendicular	In-line	Perpendicular	In-line	Perpendicular
Wiring type	3-wire				2-wire	
Output type	NPN		PNP		—	
Applicable load	IC circuit, Relay PLC				24 VDC relay, PLC	
Power supply voltage	5, 12, 24 VDC (4.5 to 28 VDC)				—	
Current consumption	10 mA or less				—	
Load voltage	28 VDC or less		—		24 VDC (10 to 28 VDC)	
Load current	40 mA or less		80 mA or less		5 to 40 mA	
Internal voltage drop	1.5 V or less (0.8 V or less at 10 mA load current)		0.8 V or less		4 V or less	
Leakage current	100 μA or less at 24 VDC				0.8 mA or less	
Indicator light	Actuated position Red LED lights up Optimum operating position Green LED lights up					

Grommet



Caution

Operating Precautions

Do not use anything other than the mounting screws attached to the auto switch body to secure the switch. If screws other than those specified are used, it may cause the switch to be damaged.

Auto Switch Internal Circuit

D-F9NW, F9NWV

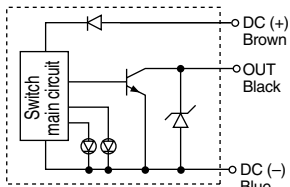

D-F9PW, F9PWV

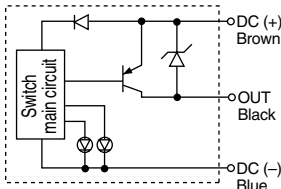

D-F9BW, F9BWV

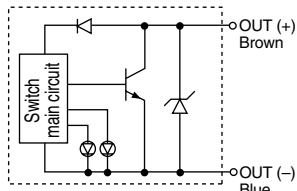

Indicator light

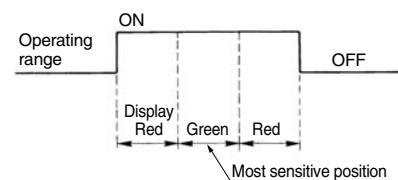

Lead wires

- Oilproof vinyl heavy-duty cord, 0.11" (ø2.7mm), 20" (0.5m)
- 2.3x 10⁻⁴in² (0.15mm²) x 3 cores (Brown, Black, Blue)
- 2.8x 10⁻⁴in² (0.18mm²) x 2 cores (Brown, Blue)

Note 1) Refer to page 50 for auto switch common specifications.

Note 2) Refer to page 50 for lead wire lengths.

Weight

Unit: OZ, () :g

Model	D-F9NW(V)	D-F9PW(V)	D-F9BW(V)
Lead wire length in (m)	20 (0.5)	0.25 (7)	0.25 (7)
	118 (3)	1.20 (34)	1.20 (34)
	197 (5)	1.98 (56)	1.98 (56)

Dimensions

Unit: in

() : mm

D-F9□W

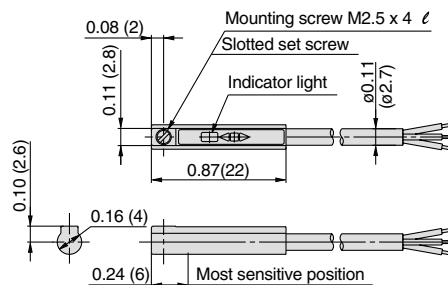

D-F9□WV

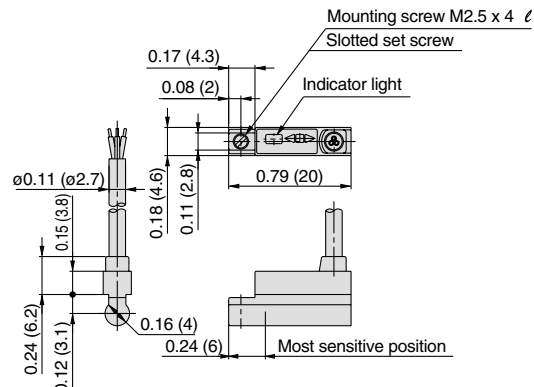

Water Resistant 2-color Indication Type Solid State Switch: Direct Mounting Style D-F9BAL



Refer to www.smcworld.com for details of products compatible with overseas standards.

Auto Switch Specifications

PLC: Programmable Logic Controller

Grommet

Water (coolant) resistant type

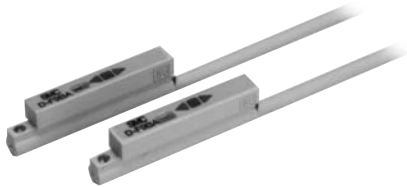

⚠ Caution

Operating Precautions

- ① Please consult with SMC if using coolant liquid other than water based solution.
- ② Do not use anything other than the mounting screws attached to the auto switch body to secure the switch. If screws other than those specified are used, it may cause the switch to be damaged.

D-F9BAL (With indicator light)	
Auto switch part no.	D-F9BAL
Wiring type	2-wire
Output type	—
Applicable load	24 VDC relay, PLC
Power supply voltage	—
Current consumption	—
Load voltage	24 VDC (10 to 28 VDC)
Load current	5 to 30 mA
Internal voltage drop	5 V or less
Leakage current	1 mA or less at 24 VDC
Indicator light	Actuated position Red LED lights up Optimum operating position Green LED lights up

- Lead wires
Oilproof vinyl heavy -duty cord, 0.11" (ø2.7mm), 20" (0.5m)
2.8x 10⁻⁴in² (0.18mm²) x 2 cores (Brown, Blue)

Note 1) Refer to page 50 for auto switch common specifications.

Note 2) Refer to page 50 for lead wire lengths.

Weight

Unit: lbs

Model	D-F9BA	
Lead wire length inch (m)	20 (0.5)	—
	118 (3)	1.37 (37)
	197 (5)	2.01 (57)

(): g

Auto Switch Internal Circuit

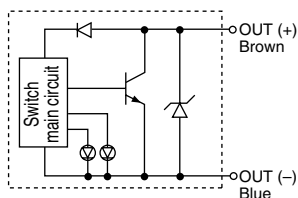

Indicator light

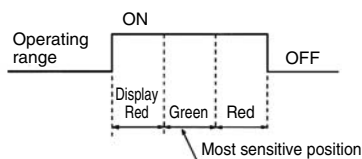

Dimensions

Unit: in

(): mm

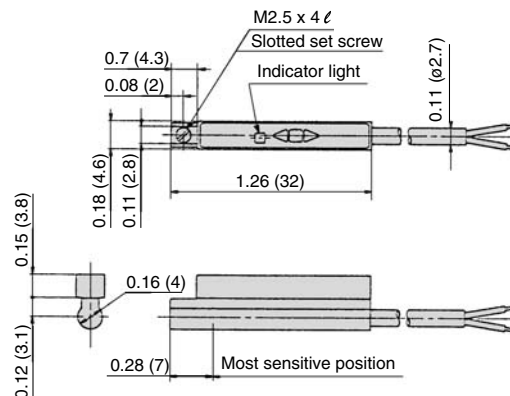





Series **NCQ8**

Safety Instructions

These safety instructions are intended to prevent a hazardous situation and/or equipment damage. These instructions indicate the level of potential hazard by a label of "**Caution**", "**Warning**" or "**Danger**". To ensure safety, be sure to observe ISO 4414 Note 1), JIS B 8370 Note 2) and other safety practices.

 **Caution** : Operator error could result in injury or equipment damage.

 **Warning** : Operator error could result in serious injury or loss of life.

 **Danger** : In extreme conditions, there is a possible result of serious injury or loss of life.

Note 1) ISO 4414: Pneumatic fluid power – General rules relating to systems

Note 2) JIS B 8370: Pneumatic system axiom

Warning

1. The compatibility of pneumatic equipment is the responsibility of the person who designs the pneumatic system or decides its specifications.

Since the products specified here are used in various operating conditions, their compatibility for the specific pneumatic system must be based on specifications or after analysis and/or tests to meet your specific requirements. The expected performance and safety assurance will be the responsibility of the person who has determined the compatibility of the system. This person should continuously review the suitability of all items specified, referring to the latest catalog information with a view to giving due consideration to any possibility of equipment failure when configuring a system.

2. Only trained personnel should operate pneumatically operated machinery and equipment.

Compressed air can be dangerous if handled incorrectly. Assembly, handling or maintenance of pneumatic systems should be performed by trained and experienced operators.

3. Do not service machinery/equipment or attempt to remove components until safety is confirmed.

1. Inspection and maintenance of machinery/equipment should only be performed once measures to prevent falling or runaway of the driven object have been confirmed.
2. When equipment is to be removed, confirm the safety process as mentioned above. Cut the supply pressure for this equipment and exhaust all residual compressed air in the system.
3. Before machinery/equipment is restarted, take measures to prevent shooting-out of cylinder piston rod, etc.

4. Contact SMC if the product is to be used in any of the following conditions:

1. Conditions and environments beyond the given specifications, or if product is used outdoors.
2. Installation on equipment in conjunction with atomic energy, railway, air navigation, vehicles, medical equipment, food and beverages, recreation equipment, emergency stop circuits, clutch and brake circuit in press applications, or safety equipment.
3. An application which has the possibility of having negative effects on people, property, or animals, requiring special safety analysis.



Series NCQ8 Actuator Precautions 1

Be sure to read before handling.

Design

Warning

1. **There is a danger of sudden action by air cylinders if sliding parts of machinery are twisted, etc., and changes in forces occur.**

In such cases, bodily injury may occur, e.g., by having hands or get in the machinery, or damage to the machinery itself may occur. Therefore, the machine should be designed to prevent such dangers.

2. **A protective cover is recommended to minimize the risk of personal injury.**

If a driven object and moving parts of a cylinder pose a danger of personal injury, design the structure to avoid contact with the human body.

3. **Securely tighten all stationary parts and connected parts so that they will not become loose.**

Particularly when a cylinder operates with high frequency or is installed where there is a lot of vibration, ensure that all parts remain secure.

4. **A deceleration circuit or shock absorber may be required.**

When a driven object is operated at high speed or the load is heavy, a cylinder's cushion will not be sufficient to absorb the impact. Install a deceleration circuit to reduce the speed before cushioning, or install an external shock absorber to relieve the impact. In cases such as these, the rigidity of the machinery should also be examined.

5. **Consider a possible drop in operating pressure due to a power outage, etc.**

When a cylinder is used as part of a clamping mechanism, there is a danger of work pieces dropping if there is a decrease in clamping force due to a drop in circuit pressure caused by a power outage, etc. Therefore, safety equipment should be installed to prevent human injury or damage to machinery. Suspension mechanisms and lifting devices also require for drop prevention measures.

6. **Consider a possible loss of power source.**

Measures should be taken to protect against human injury and equipment damage in the event that there is a loss of power to equipment controlled by pneumatics, electricity or hydraulics, etc.

7. **Design circuitry to prevent sudden lurching of driven objects.**

Take special care when a cylinder is driven by an exhaust center type directional control valve or when starting up after residual pressure is exhausted from the circuit, etc. The piston and its driven object will lurch at high speed if pressure is applied to one side of the cylinder because of the absence of air pressure inside the cylinder. Therefore, equipment should be selected and circuits designed to prevent sudden lurching because there is a danger of human injury particularly to limbs, and/or damage to equipment when this occurs.

8. **Consider emergency stops.**

Design the system so that human injury and/or damage to machinery and equipment will not be caused when machinery is stopped by a safety device responding to abnormal conditions such as a power outage or a manual emergency stop.

9. **Consider the action when operation is restarted after an emergency stop or abnormal stop.**

Design

Design the machinery so that human injury or equipment damage will not occur upon restart of operation. When the cylinder has to be reset at the starting position, install safe manual control equipment.

Selection

Warning

1. **Confirm the specifications.**

The products featured in this catalog are designed for use in industrial compressed air systems. If the products are used in conditions where pressure and/or temperature are out of the range of specifications, damage and/or malfunction may occur. Do not use in these conditions. (Refer to specifications.) Consult SMC if fluid other than compressed air is required.

2. **Intermediate stops**

When intermediate stopping of a cylinder piston is performed with a 3-position closed center type directional control valve, it is difficult to achieve stopping positions as accurate and precise as with hydraulic pressure due to the compressibility of air.

In addition, since valves and cylinders are not guaranteed for zero air leakage, it may not be possible to hold a stopped position for an extended period of time. Consult SMC in cases where you need to hold a stopped position for long periods.

Caution

1. **Operate within the limit of the maximum usable stroke.**

Operation with a stroke exceeding the maximum stroke range will damage the piston rod. Operate within the standard stroke range.

2. **Operate the piston in such a way that collision damage will not occur at the stroke end.**

3. **Use a speed controller to adjust the cylinder drive speed, gradually increasing from a low speed to the desired speed setting.**

Mounting

Caution

1. **Be sure to connect so that the rod axis is aligned with the load and movement direction.**

If they are not aligned, stress could be applied to the rod and the tube, causing the inner surface of the tube, the bushing, the rod surface, and the seals to wear and to become damaged.

2. **When using an external guide, connect the rod end and the load in such a way that there is no interference at any positions within the stroke.**

3. **Do not scratch or gouge the sliding parts of the cylinder tube or piston rod by striking or grasping them with other objects.**

Cylinder bores are manufactured to precise tolerances, so that even a slight deformation may cause malfunction.

Also, scratches or gouges in the piston rod may lead to damaged seals and cause air leakage.



Series NCQ8 Actuator Precautions 2

Be sure to read before handling.

Mounting

⚠ Caution

4. Prevent sticking (through friction) of the rotating parts.

Prevent sticking (through friction) of the rotating parts, for example pins, by applying grease.

5. Do not use until you can verify that equipment can operate properly.

Following mounting repairs, or conversions, verify correct mounting by conducting suitable function and leakage tests after piping and power connections have been made.

6. Instruction manual

The product should be mounted and operated after thoroughly reading the manual and understanding its contents. Keep the instruction manual where it can be referred to as needed.

Piping

⚠ Caution

1. Preparation before piping

Before piping is connected, it should be thoroughly blown out with air (flushing) or washed to remove chips, cutting oil, and other debris from inside the pipe.

2. Wrapping of Pipe tape

When screwing together pipes and fittings, etc., be certain that chips from the pipe threads and sealing material do not get inside the piping.

Also, when pipe tape is used, leave 1.5 to 2 thread ridges exposed at the end of the threads.

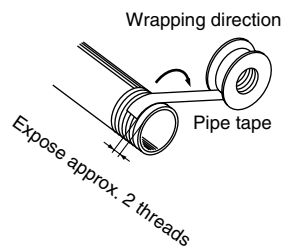

Lubrication

⚠ Caution

1. Lubrication of non-lube type cylinder

The cylinder is lubricated for life at the factory and can be used without any further lubrication.

However, in the event that it is lubricated additionally, be sure to use class 1 turbine oil (with no additives) ISO VG32.

Stopping lubrication later may lead to malfunctions because the new lubricant will cancel out the original lubricant. Therefore, lubrication must be continued once it has been started.

Air Supply

⚠ Warning

1. Use clean air.

Do not use compressed air containing chemicals, synthetic oils containing organic solvents, salt or corrosive gases, as this can cause damage or malfunction.

⚠ Caution

1. Install air filters.

Install air filters at the upstream side of valves. The filtration degree should be 5 μm or finer.

2. Install an after-cooler, air dryer or water separator, etc.

Air that includes excessive drainage or condensate may cause malfunction of valves and other pneumatic equipment. To prevent this, install an after-cooler, air dryer or water separator, etc.

3. Use the product within the specified range of fluid and ambient temperature.

Take measures to prevent freezing when 5°C or less, since moisture in circuits can freeze and cause damage to seals and lead to malfunctions.

Refer to SMC's Best Pneumatics catalog Vol.14 for further details on compressed air quality.

Operating Environment

⚠ Warning

1. Do not use in environments where there is a danger of corrosion.

2. In dusty locations, or where water or oil may splash on the equipment, install something like a cover to protect the rod.

3. When using auto switches, do not operate in an atmosphere with strong magnetic fields.

Maintenance

⚠ Warning

1. Perform maintenance inspection according to the procedure indicated in the instruction manual.

Improper handling and maintenance may cause malfunctioning and damage of machinery or equipment to occur.

2. Removal of components, and supply/exhaust of compressed air.

When equipment is removed, first check measures to prevent dropping of driven objects and run-away of equipment, etc. Then cut off the supply pressure and electric power, and exhaust all compressed air from the system.

When machinery is restarted, proceed with caution after confirming measures to prevent cylinder lurching.

⚠ Caution

1. Filter drainage

Drain out condensate from air filters regularly.



Series NCQ8 Auto Switch Precautions 1

Be sure to read before handling.

Design and Selection

⚠ Warning

1. Confirm the specifications.

Read the specifications carefully and use this product appropriately. The product may be damaged or malfunction if it is used outside of its specification range (eg. current load, voltage, temperature or impact, etc.).

2. Take precautions when multiple actuators are used close together.

When two or more actuators are lined up in close proximity to each other, magnetic field interference may cause the switches to malfunction. Maintain a minimum cylinder separation of 40 mm.

3. Pay attention to the length of time that a switch is on at an intermediate stroke position.

When an auto switch is placed at an intermediate position of the stroke and a load connected to the auto switch is driven at the time the slide table passes, the auto switch will operate. However if the speed is too great, the operating time will be shortened and the load may not operate properly. The maximum detectable piston speed is:

$$V \text{ (ft/s)} = \frac{\text{Auto switch operating range (ft)}}{\text{Load operating time (ms)}} \times 1000$$

4. Keep wiring as short as possible.

<Reed switch>

As the length of the wiring to a load gets longer, the rush current at the time the switch is turned ON becomes greater, which may shorten the product's life. (The switch will stay ON all the time.)

- 1) Use a contact protection box when the wire length is 16.4 ft (5 m) or longer.

<Solid state switch>

- 2) Although the wire length should not affect switch function, use a wire that is 328 ft (100 m) or shorter.

5. Take precautions for the internal voltage drop of the switch.

<Reed switch>

- 1) Switches with an indicator light (Except D-A96, A96V)
 - If auto switches are connected in series as shown below, take note that there will be a large voltage drop because of internal resistance from the light emitting diodes. (Refer to internal voltage drop in the auto switch specifications.) [The voltage drop will be "n" times larger when "n" auto switches are connected.] Even though an auto switch operates normally, the load may not operate.

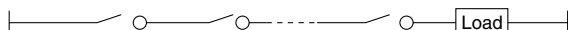

- Similarly, when operating below a specified voltage, it is possible that the load may be ineffective even though the auto switch function is normal. Therefore, the formula below should be satisfied after confirming the minimum operating voltage of the load.

$$\text{Supply voltage} - \text{Internal voltage drop of switch} > \text{Minimum operating voltage of load}$$

- 2) If the internal resistance of a light emitting diode causes a problem, select a switch without an indicator light (Model A90, A90V).

<Solid state switch>

- 3) Generally, the internal voltage drop will be greater with a 2-wire solid state auto switch than with a reed switch. Take the same precautions as in item (1) as mentioned above. Also, note that a 12 VDC relay is not applicable.

6. Pay attention to leakage current.

<Solid state switch>

With a 2-wire solid state auto switch, current (leakage current) flows to the load to operate the internal circuit even when in the OFF state.

$$\text{Current to operate load (Input OFF signal of controller)} > \text{Leakage current}$$

If the condition given in the above formula is not met, internal circuit will not reset correctly (stays ON). Use a 3-wire switch if this specification cannot be satisfied.

Moreover, leakage current flow to the load will be "n" times larger when "n" auto switches are connected in parallel.

7. Do not use a load that generates surge voltage.

<Reed switch>

If driving a load such as a relay which generates a surge voltage, use a contact protection box.

<Solid state switch>

Although a zener diode for surge protection is connected at the output side of a solid state auto switch, damage may still occur if a surge is applied repeatedly. When directly driving a load which generates a surge, such as a relay or solenoid valve, use a switch with a built-in surge absorbing element.

8. Cautions for use in an interlock circuit

When an auto switch is used for an interlock signal requiring high reliability, devise a double interlock system to safeguard against malfunctions. The double interlock system should provide a mechanical protection function or use another switch (sensor) together with the auto switch. Also perform periodic inspection and confirm proper operation.

9. Ensure sufficient clearance for maintenance activities.

When designing an application, be sure to allow sufficient clearance for maintenance and inspections.



Series NCQ8 Auto Switch Precautions 2

Be sure to read before handling.

Mounting and Adjustment

Warning

1. Do not drop or bump.

Do not drop, bump or apply excessive impacts (300m/s² or greater for reed switches and 1000m/s² or greater for solid state switches) while handling.

Although the body of the switch may not be damaged, the inside of the switch could be damaged and cause a malfunction.

2. Do not carry an actuator by the auto switch lead wires.

Never carry a cylinder by its lead wires. This may not only cause broken lead wires, but it may cause internal elements of the switch to be damaged by the stress.

3. Mount switches using the proper tightening torque.

When a switch is tightened above the torque specification, the mounting screws, or switch may be damaged. On the other hand, tightening below the torque specification may allow the switch to slip out of position.

4. Mount a switch at the center of the operating range.

Adjust the mounting position of an auto switch so that the piston stops at the center of the operating range (the range in which a switch is ON). (The mounting positions shown in the catalog indicate the optimum position at the stroke end.) If mounted at the end of the operating range (around the borderline of ON and OFF), operation will be unstable.

<D-M9□>

When the D-M9 auto switch is used to replace old series auto switch, it may not activate depending on operating condition because of its shorter operating range.

Such as

- Application where the stop position of actuator may vary and exceed the operating range of the auto switch, for example, pushing, pressing, clamping operation, etc.
- Application where the auto switch is used for detecting an intermediate stop position of the actuator. (In this case the detecting time will be reduced.)

In these applications, please set the auto switch to the center of the required detecting range.

Caution

1. Fix the switch with the appropriate screw installed on the switch body. The switch may be damaged if other screws are used.

Wiring

Warning

1. Avoid repeatedly bending or stretching lead wires.

Broken lead wires will result from repeatedly applying bending stress or stretching force to the lead wires.

2. Be sure to connect the load before power is applied.

<2-wire type>

If the power is turned ON when an auto switch is not connected to a load, the switch will be instantly damaged because of excess current.

Wiring

3. Confirm proper insulation of wiring.

Be certain that there is no faulty wiring insulation (such as contact with other circuits, ground fault, improper insulation between terminals, etc.). Damage may occur due to excess current flow into a switch.

4. Do not wire in conjunction with power lines or high voltage lines.

Wire separately from power lines or high voltage lines, avoiding parallel wiring or wiring in the same conduit with these lines. Control circuits containing auto switches may malfunction due to noise from these lines.

5. Do not allow short circuit of loads.

<Reed switch>

If the power is turned ON with a load in a short circuited condition, the switch will be instantly damaged because of excess current flow into the switch.

<Solid state switch>

D-M9□ and all models of PNP output type switches do not have built-in short circuit protection circuits. If loads are short circuited, the switches will be instantly damaged, as in the case of reed switches.

Take special care to avoid reverse wiring with the brown power supply line and the black output line on 3-wire type switches.

6. Avoid incorrect wiring.

<Reed switch>

A 24 VDC switch with indicator light has polarity. The brown lead wire is (+), and the blue lead wire is (-).

1) If connections are reversed, the switch will still operate, but the light emitting diode will not light up.

Also note that a current greater than the maximum specified one will damage a light emitting diode and make it inoperable. Applicable models: D-A93, A93V

<Solid state switch>

1) Even if connections are reversed on a 2-wire type switch, the switch will not be damaged because it is protected by a protection circuit, but it will remain in a normally ON state. But reverse wiring in a short circuit load condition should be avoided to protect the switch from being damaged.

2) Even if (+) and (-) power supply line connections are reversed on a 3-wire type switch, the switch will be protected by a protection circuit. However, if the (+) power supply line is connected to the blue wire and the (-) power supply line is connected to the black wire, the switch will be damaged.

<D-M9□>

D-M9□ does not have built-in short circuit protection circuit. Be aware that if the power supply connection is reversed (e.g. (+) power supply wire and (-) power supply wire connection is reversed), the switch will be damaged.

* Lead wire color changes

Lead wire colors of SMC switches have been changed in order to meet NECA Standard 0402 for production beginning September, 1996 and thereafter. Please refer to the tables provided.

Special care should be taken regarding wire polarity during the time that the old colors still coexist with the new colors.

2-wire			3-wire		
	Old	New		Old	New
Output (+)	Red	Brown	Power supply	Red	Brown
Output (-)	Black	Blue	GND	Black	Blue
			Output	White	Black



Series NCQ8

Auto Switch Precautions 3

Be sure to read before handling.

Wiring

⚠ Caution

1. When the cable sheath is stripped, confirm the stripping direction. The insulator may be split or damaged depending on the direction. (D-M9□ only)

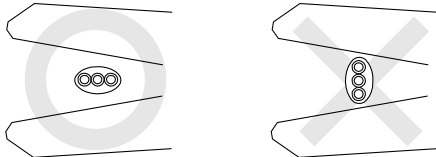

Recommended tool

Manufacturer	Model name	Model no.
VESSEL	Wire stripper	No 3000G
TOKYO IDEAL CO., LTD	Strip master	45-089

* Stripper for a round cable (ø2.0) can be used for a 2-wire type cable.

Operating Environment

⚠ Warning

1. **Never use in an atmosphere of explosive gases.**
The construction of the auto switch is not intended to prevent explosion. Never use in an atmosphere with an explosive gas since this may cause a serious explosion.
2. **Do not use in an area where a magnetic field is generated.**
The auto switch will malfunction or the magnets inside of an actuator will become demagnetized if used in such an environment.
3. **Do not use in an environment where the auto switch will be continually exposed to water.**
The switch satisfies the IEC standard IP67 construction (JIS C 0920: watertight construction). Nevertheless, it should not be used in applications where it is continually exposed to water splash or spray. This may cause deterioration of the insulation or swelling of the potting resin inside switch causing malfunction.
4. **Do not use in an environment with oil or chemicals.**
Consult with SMC if an auto switch will be used in an environment laden with coolant, cleaning solvent, various oils or chemicals. If an auto switch is used under these conditions for even a short time, it may be adversely effected by deterioration of insulation, malfunction due to swelling of the potting resin, or hardening of the lead wires.
5. **Do not use in an environment with temperature cycles.**
Consult with SMC if a switch is used where there are temperature cycles other than normal temperature changes, as they may adversely affect a switch internally.

Operating Environment

6. **Do not use in an environment where there is excessive impact shock.**

<Reed switch>

When excessive impact (984 ft/s² or more) is applied to a reed switch during operation, the contact point may malfunction and generate a signal momentarily (1 ms or less) or cut off. Consult with SMC regarding the need to use a solid state switch in a specific environment.

7. **Do not use in an area where surges are generated.**

<Solid state switch>

When there are units (such as solenoid type lifters, high frequency induction furnaces, motors, etc.) that generate a large amount of surge in the area around an actuator with a solid state auto switch, their proximity or pressure may cause deterioration or damage to the internal circuit of a switch. Avoid sources of surge generation and crossed lines.

8. **Avoid accumulation of iron debris or close contact with magnetic substances.**

When a large amount of ferrous debris such as machining chips or spatter is accumulated, or a magnetic substance (something attracted by a magnet) is brought into close proximity with an auto switch cylinder, it may cause auto switches to malfunction due to a loss of the magnetic force inside the cylinder.

Maintenance

⚠ Warning

1. **Perform the following maintenance periodically in order to prevent possible danger due to unexpected auto switch malfunction.**
 - 1) Securely tighten switch mounting screws.
If screws become loose or the mounting position is dislocated, retighten them after readjusting the mounting position.
 - 2) Confirm that there is no damage to the lead wires.
To prevent faulty insulation, replace switches or repair lead wires, etc., if damage is discovered.
 - 3) Confirm that the green light on the 2-color display type switch lights up.
Confirm that the green LED is ON when stopped at the set position. If the red LED is ON, when stopped at the set position, the mounting position is not appropriate. Readjust the mounting position until the green LED lights up.

Other

⚠ Warning

1. **Consult with SMC concerning water resistance, elasticity of lead wires, usage at welding sites, etc.**

Global Manufacturing, Distribution and Service Network

Worldwide Subsidiaries

EUROPE

AUSTRIA
SMC Pneumatik GmbH (Austria)

CZECH
SMC Industrial Automation CZ s.r.o.

DENMARK
SMC Pneumatik A/S

FINLAND
SMC Pneumatics Finland OY

FRANCE
SMC Pneumatique S.A.

GERMANY
SMC Pneumatik GmbH

HUNGARY
SMC Hungary Ipari Automatizálási Kft.

IRELAND
SMC Pneumatics (Ireland) Ltd.

ITALY
SMC Italia S.p.A.

LATVIA
SMC Pneumatics Latvia SIA

NETHERLANDS
SMC Pneumatics BV

NORWAY
SMC Pneumatics Norway A/S

POLAND
SMC Industrial Automation Polska Sp.z.o.o.

ROMANIA
SMC Romania S.r.l.

RUSSIA
SMC Pneumatik LLC.

SLOVAKIA
SMC Priemyselna Automatizacia, s.r.o.

SLOVENIA
SMC Industrijska Avtomatika d.o.o.

SPAIN/PORTUGAL
SMC España, S.A.

SWEDEN
SMC Pneumatics Sweden AB

SWITZERLAND
SMC Pneumatik AG

UK
SMC Pneumatics (U.K.) Ltd.

ASIA

CHINA
SMC (China) Co., Ltd.

HONG KONG
SMC Pneumatics (Hong Kong) Ltd.

INDIA
SMC Pneumatics (India) Pvt. Ltd.

INDONESIA
PT. SMC Pneumatics Indonesia

MALAYSIA
SMC Pneumatics (S.E.A.) Sdn. Bhd.

PHILIPPINES
SHOKETSU-SMC Corporation

SINGAPORE
SMC Pneumatics (S.E.A.) Pte. Ltd.

SOUTH KOREA
SMC Pneumatics Korea Co., Ltd.

TAIWAN
SMC Pneumatics (Taiwan) Co., Ltd.

THAILAND
SMC Thailand Ltd.

NORTH AMERICA

CANADA
SMC Pneumatics (Canada) Ltd.

MEXICO
SMC Corporation (Mexico) S.A. DE C.V.

USA
SMC Corporation of America

SOUTH AMERICA

ARGENTINA
SMC Argentina S.A.

BOLIVIA
SMC Pneumatics Bolivia S.R.L.

BRAZIL
SMC Pneumaticos do Brazil Ltda.

CHILE
SMC Pneumatics (Chile) S.A.

VENEZUELA
SMC Neumatica Venezuela S.A.

OCEANIA

AUSTRALIA
SMC Pneumatics (Australia) Pty. Ltd.

NEW ZEALAND
SMC Pneumatics (N.Z.) Ltd.

U.S. & Canadian Sales Offices

EAST

Atlanta
Tel: (770) 624-1940
Fax: (770) 624-1943

Boston
Tel: (603) 610-2500
Fax: (603) 610-2600

Charlotte
Tel: (704) 947-7556
Fax: (704) 947-8556

Nashville
Tel: (615) 331-0020
Fax: (615) 331-9950

New Jersey
Tel: (732) 537-0122
Fax: (732) 537-0421

Richmond
Tel: (804) 527-0500
Fax: (804) 527-2100

Rochester
Tel: (585) 381-3890
Fax: (585) 381-3941

Tampa
Tel: (727) 530-9766
Fax: (727) 530-9465

MIDWEST

Chicago
Tel: (630) 449-0600
Fax: (630) 449-0601

Cincinnati
Tel: (859) 647-5600
Fax: (859) 647-5609

Cleveland
Tel: (330) 963-2727
Fax: (330) 963-2730

Detroit
Tel: (248) 299-0202
Fax: (248) 293-3333

Indianapolis
Tel: (317) 899-4845
Fax: (317) 898-3896

Milwaukee
Tel: (262) 253-4801
Fax: (262) 253-4802

Minneapolis
Tel: (952) 943-1275
Fax: (952) 943-1614

St. Louis
Tel: (314) 439-8900
Fax: (314) 439-8901

WEST

Austin
Tel: (512) 926-2646
Fax: (512) 926-7055

Dallas
Tel: (972) 446-1140
Fax: (972) 446-1251

Houston
Tel: (713) 460-0776
Fax: (713) 460-0773

Los Angeles
Tel: (714) 669-1701
Fax: (714) 669-1715

Phoenix
Tel: (480) 967-2570
Fax: (480) 829-0824

Portland
Tel: (503) 644-1696
Fax: (503) 644-4041

San Francisco
Tel: (408) 943-9600
Fax: (408) 943-9111

CANADA

Montreal
Tel: (514) 733-9595
Fax: (514) 733-1771

Quebec City
Tel: (418) 654-1997
Fax: (418) 654-1998

Toronto
Tel: (905) 812-0400
Fax: (905) 812-8686

Vancouver
Tel: (604) 517-1646
Fax: (604) 517-1647

Windsor
Tel: (519) 944-0555
Fax: (519) 944-1870

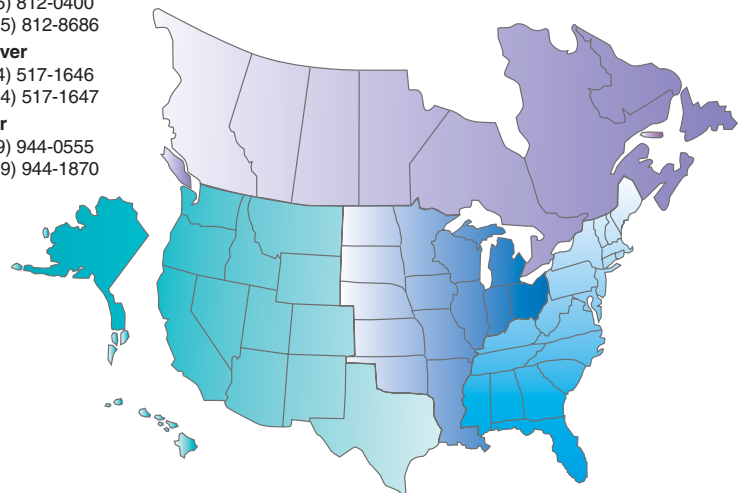

SMC Corporation of America
3011 N. Franklin Road
Indianapolis IN 46226
(317) 899-4845
www.smcusa.com

SMC Pneumatics (Canada) Ltd.
6768 Financial Drive Mississauga
Ontario L5N 7J6 Canada
(905) 812-0400
www.smcpcanada.ca

Call 1-800-SMC-SMC1 (1-800-762-7621) to reach the branch nearest you

